

Simple Machines

Curriculum Pack



LEGO and the LEGO logo are trademarks of the/son des marques de commerce du/son marcas registradas de LEGO Group. ©2016 The LEGO Group. All rights reserved. 2017.01.01



education

Table of Contents

1. Introduction	3
Who is it for?	3
What is it for?	3
What is in it?.....	4
Assessment.....	6
Classroom Management Tips	8
LEGO® Education's 4C approach.....	9
What are simple machines?.....	10
2. Curriculum	11
3. Gears	
Overview: Gears	14
Images for Classroom Use.....	17
Principle Models: Gears.....	19
Main Activity: Merry-Go-Round.....	25
Problem-Solving Activity: Popcorn Cart.....	36
4. Wheels and Axles	
Overview: Wheels and Axles	41
Images for Classroom Use.....	44
Principle Models: Wheels and Axles.....	46
Main Activity: Go-Cart	53
Problem-Solving Activity: Wheelbarrow	64
5. Levers	
Overview: Levers	69
Images for Classroom Use.....	73
Principle Models: Levers.....	75
Main Activity: Catapult	79
Problem-Solving Activity: Railroad Crossing Gate.....	90
6. Pulleys	
Overview: Pulleys.....	95
Images for Classroom Use.....	98
Principle Models: Pulleys	100
Main Activity: Crazy Floors.....	106
Problem-Solving Activity: Crane	117
7. Glossary	122
8. LEGO® Element Survey	126

Introduction

LEGO® Education is pleased to bring you the “Simple Machines” curriculum pack.

Who is it for?

This material is designed for use by teachers of students in grades three through five, who wish to introduce their students to the following simple machines:

- Gears
- Wheels and Axles
- Levers
- Pulleys

Working in pairs, students of any academic background can build, learn and investigate using the models and activities included in this curriculum pack.

What is it for?

LEGO Education STEM solutions enable students to work as young scientists and engineers, helping them to investigate and understand the operation of simple and compound machines found in everyday life. The materials promote an enjoyable but challenging classroom environment in which students can develop skills such as creative problem-solving, communication of ideas, and teamwork. The activities lead students to make initial use of scientific method through observation, reasoning, prediction, and critical thinking.

The “Simple Machines” curriculum pack enables you to partially cover the following Crosscutting Concepts and overall Science and Engineering Practices, which have been set forth in the Next Generation Science Standards (NGSS).

Science and Engineering Practices:

- Asking questions (for science) and defining problems (for engineering)
- Developing and using models
- Planning and carrying out investigations
- Analyzing and interpreting data
- Using mathematics and computational thinking
- Constructing explanations (for science) and designing solutions (for engineering)
- Engaging in argument from evidence
- Obtaining, evaluating, and communicating information

Crosscutting Concepts:

- Patterns
- Cause and effect: Mechanism and explanation
- Scale, proportion, and quantity
- Systems and system models
- Energy and matter: Flows, cycles, and conservation
- Structure and function
- Stability and change



What is in it?

The 9689 Brick Set

The set consists of four full-color sets of building instructions for the four simple machines, including building instructions for both the principle models and the main models, and 204 LEGO® elements, including an element (brick) separator. The main models and the principle models described in this curriculum pack can all be built from the elements in the set, though only one at a time.

The 9689 Curriculum Pack

This curriculum pack contains teaching suggestions and materials that will enable teachers to make effective use of the Simple Machines Set in class. The curriculum pack is divided into the following sections:

Curriculum:

Please refer to the NGSS and Common Core State Standards grids in the 'Curriculum' section of this curriculum pack to see which of the main activities and problem-solving activities match your current teaching program.

The four simple machine sections:

These sections provide information and activities for the four simple machines: gears, wheels and axles, levers, and pulleys. All four simple machine units are presented in the same way.

- An overview of the simple machine in focus is given. The overview starts with an introduction and with ideas for establishing the concept and providing the vocabulary relevant to the simple machine. A brief outline for using the principle models is also included.
- Following this is an overview of relevant images from Images for Classroom Use, a collection of photographs, pictures, drawings, and illustrations that can be used to support the teaching of simple machines. These images are intended to help students understand the links between the models they build and the real world. There is also an overview of the elements used for building both the principle models and the main models.
- Each unit then introduces the Teacher's Notes and student worksheets for the principle models, the related main model, and the problem-solving activity.

9689



Teacher's Notes

There are detailed Teacher's Notes for each simple machine section. In some cases, additional materials will be necessary for the main activities and investigations; these are listed. The Teacher's Notes indicate key learning areas, give suggestions for carrying out each main activity, provide hints, questions, and vocabulary specific to the main activity, and suggest further ideas for investigation. The answers to questions asked on the Student Worksheets, together with comments to the teacher, are written in blue italics in the Teacher's Notes.

In the Teacher's Notes you will find eight main activities, each of which includes including student worksheets, assessment tools, 'Connect' stories, and questions and ideas for further investigation. You will also find four problem-solving activities, which also include assessment tools and 'Connect' stories, as well as a design brief and a possible design solution – all ready for you to introduce to your students.

Main Activities and Student Worksheets

The student worksheets help students to work individually, in pairs, or in groups to apply the knowledge they have acquired about the simple machine concept through building or discussion activities. The student worksheets can be copied as required. Writing is kept to a minimum on the student worksheets for the principle models—students only need to mark choices, draw lines to label illustrations, or write numbers.

On the student worksheets for the main models students will be challenged to predict an outcome, which they will then investigate, and finally they will document their findings.

Text on the student worksheets is kept to a minimum, but nevertheless early readers may need help in understanding the written instructions. Icons have been included on the student worksheets to help students through the main activity in focus; these symbolize, for example, that something must be marked or drawn, circled, or joined, or that students are asked to write in a number.

Problem-Solving Activities

These problem-solving activities are intended to encourage students to apply the knowledge they have gained from both the different principle models and/or the main model concerning the simple machine in focus. The suggested problem-solving model solution that is included is only meant as a guiding principle to solving the problem posed.

If possible, take a picture of each of the students' model solutions and have the students explain how they have solved the problem. Keep the pictures as inspirational material for future problem solvers.

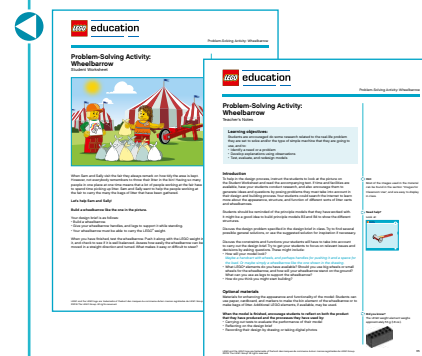
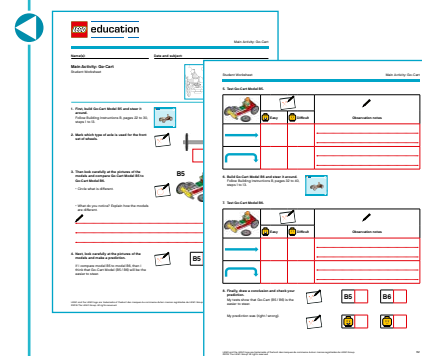
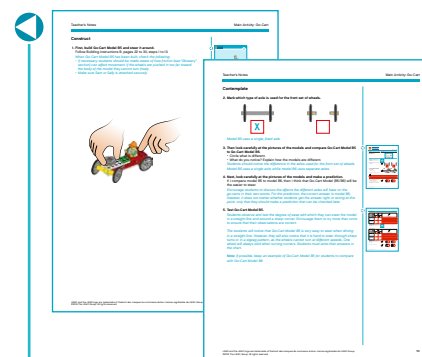

Assessments

Assessment materials are provided for all four of the main activities and the four problem-solving activities. These materials define clear learning goals before the students start each activity and motivate the students to challenge themselves throughout the learning process. You can also use these materials to assess your students' development in different learning areas.

Student Worksheets

The student worksheets should be used to document each student's work and to support them throughout each of the main activities. These worksheets are an easy-to-use tool for assessing each student's level and achievement during the activities. They can also comprise a valuable part of the each student's logbook or portfolio.

Student Self-Assessment Tools

There are two generic student self-assessment rubrics. One has been developed for use during the main activities, and the other is intended for use with the problem-solving activities. These rubrics help students to reflect on and evaluate their work during each lesson.

Using these rubrics, students assess themselves according to the 'Four Bricks Scale' in which the biggest brick represents the highest rating. In certain situations, you might also consider asking your students to assess themselves using only two of the four bricks.

Teacher Assessment Tools

The Observation Checklists are linked directly to each of the main activities and the problem-solving activities. You can use these checklists to assess the science and engineering practices of your students individually, in pairs, or in groups.

You either can use the Emerging, Developing, Proficient, or Accomplished proficiency level descriptions described on the next page, or use other assessment criteria that are relevant to your school context.

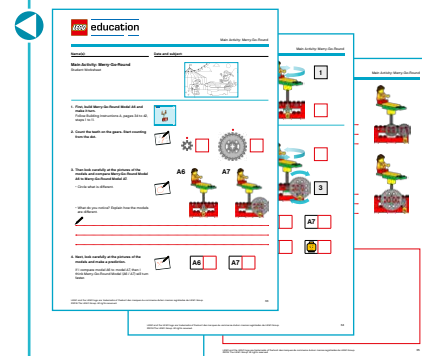

Emerging

The student is at the beginning stages of development in terms of content knowledge, ability to understand and apply content, and/or demonstration of coherent thoughts about a given topic.

Developing

The student is able to present basic knowledge only (e.g., vocabulary), and cannot yet apply content knowledge or demonstrate comprehension of the concepts being presented.

Proficient

The student has concrete levels of comprehension of the content and concepts, and can demonstrate adequately the topics, content, or concepts being taught. The ability to discuss and apply concepts outside of the required assignment is lacking.

Accomplished

The student can take concepts and ideas to the next level, apply concepts to other situations, and synthesize, apply, and extend knowledge to discussions that include extensions of ideas.

Where can I find the assessment materials?

You can find the assessment materials in the Teacher's Notes for each of the main activities and problem-solving activities.



Classroom Management Tips

For Your First LEGO® Education Activity, and Beyond

1. Before Class

- Download the curriculum pack from the URL that is printed on the lid of each LEGO® brick set.
- Open one of the sets, sort the bricks, and get to know the bricks by working with one of the principle models, followed by a main activity. Use the relevant student worksheets and assessment tools.

2. During Class

- At the beginning of the first lesson, allow the students some time to get to know the LEGO brick set.
- Use a jar to collect stray pieces.
- Make adjustments in order to challenge the students who are ready to improve and develop new skills.
- Label the boxes so that you can recognize which box belongs to which student(s).
- Plan to stop the lesson with enough time to allow the students to tidy up.

3. After Class

- If you did not finish the activity, store the LEGO sets and the models so that they are ready for the next lesson.
- Evaluate the lesson.

How much time is needed?

There are many ways to use the Simple Machines Set in your classroom, and many different ways to plan your class schedule. Activities can be completed by individuals or by small teams or groups, depending upon the number of sets that are available to your class.

If you choose to introduce the principle models of one simple machine, 2-3 of the models can be built, investigated, and explored, and the parts put away again, within a single 45-minute lesson if the students are already experienced LEGO builders.

However, if you choose to continue with a main activity, then at least two more class periods will be needed, depending on the time spent on discussion, the building skills of your students, and the time you allow for experimentation. A double lesson is ideal to be able to explore, build, and investigate in depth most of the (optional) extension ideas built into the main activity, and especially for the students to make any creative variations of their own.

In the case of the problem-solving activities, students should be able to tackle the challenge within a sequence of two lessons.

How do I organize the building instructions?

For easy classroom management we suggest storing the building instructions in binders so that they are close at hand and ready to use at the beginning of each lesson.

What's needed in my classroom?

Tables may be pushed aside to let models roll across a smooth floor and boxes may be needed for a ramp.

Students need to be able to construct in pairs facing each other or side-by-side. It is also an advantage to have a cupboard or shelves where you can store the sets lying flat with any unfinished models on top of them.

Hint

We suggest students work together in pairs, sharing a set between them.

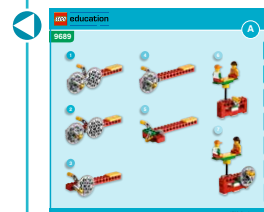

LEGO® Education's 4C approach

The main activities in the “Simple Machines” curriculum pack follow LEGO® Education's 4C approach: Connect, Construct, Contemplate, and Continue. This enables you to progress naturally through the main activities.

Connect

The Connect story places the characters Sam and Sally in real-life surroundings, linking an object/item from the real world that most students will recognize to the simple machine concept under consideration. This real-world object will closely resemble the LEGO models students will work with and build. In the Connect passage the language is more child-oriented, as it is intended for you to read aloud.

Construct

Using the building instructions, students build models covering the concepts related to the simple machine in focus. Tips are provided for testing and for making sure that each model functions as intended.

Contemplate

This stage involves students investigating the models they have constructed. Through these investigations, students will learn to observe and compare results from tests that they make, and to report on their observations. They will be encouraged to describe the outcomes of their investigations. Questions are included that are designed to further deepen students' experience and understanding of the investigation. This phase provides the opportunity for you to begin evaluating learning outcomes and the progress of individual students, especially by looking at their worksheets and talking to them about their reflections and answers.

Continue

Continued learning is always more enjoyable and creative when it is sufficiently challenging. Extension ideas are therefore provided to encourage the students to change or add features to their models and to investigate further—always with the key learning area in mind. This phase encourages students to experiment and to apply their knowledge creatively.

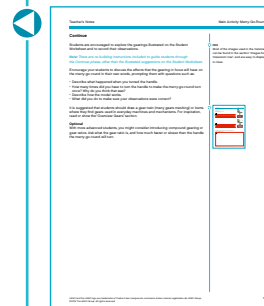
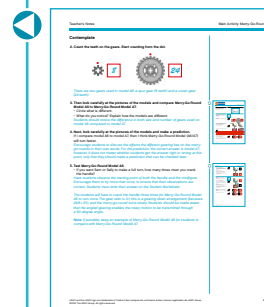
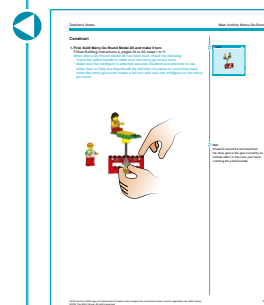
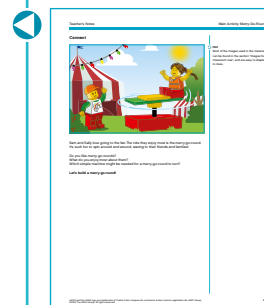

What Are Simple Machines?

We use simple machines every day—when we open a door, turn on a faucet, open a tin can, or ride a bike. Simple machines make it easy for us to do work. A force (a push or a pull effort) makes something (a mass or load) move a distance.

Simple machines have only one part to do the work and they have very few or even no moving parts. A lever is an example of such a simple machine. You can use a lever, for example a crowbar, to move a large load with a smaller effort than you would need if you did not have a machine to help you. The force applied to the lever makes the load move, but the effort needed is less than if the force was applied directly to the load. The work is thus easier to do.

The terms *load* and *effort* are used in describing how simple machines work. The load is the object that is moved, e.g., a box. The effort is the force used to do the work. In the situation illustrated, the effort is the force that someone will apply to the moving dolly to move (or lift) the load (the box).



Simple machines have very few parts; compound machines are made up of two or more simple machines. A moving dolly is one example of a compound machine. It has combined two simple machines. The handles are levers that help lift the load, and the wheel and axle help move the load forward easily. The same principle applies to a wheelbarrow.

Machines help us do many things: they help us lift, pull, split, fasten, cut, carry, mix, etc. All machines are made up of simple machines. More complicated machines (compound machines) are made up of a number of simple machines that function together to help do the work. Gears are sometimes categorized as compound machines, but in this material we have regarded them as simple machines.

Did you know?

A crowbar is a simple machine called a lever.





Did you know?

A wheelbarrow is a compound machine.



Curriculum

Objective Number	NGSS Grades 3-5  = Fully covered  = Partially covered	Simple Machines											
		Gears			Wheels and Axles			Levers		Pulleys			
		1. Principle Models: Gears	2. Main Activity: Merry-Go-Round	3. Problem-Solving Activity: Popcorn Cart	1. Principle Models: Wheels and Axles	2. Main Activity: Go-Cart	3. Problem-Solving Activity: Wheelbarrow	1. Principle Models: Levers	2. Main Activity: Catapult	3. Problem-Solving Activity: Railroad Crossing Gate	1. Principle Models: Pulleys	2. Main Activity: Crazy Floors	3. Problem-Solving Activity: Crane
Disciplinary Core Ideas: Physical Science													
1	MS-PS2 Motion and Stability: Forces and Interactions												
Crosscutting Concepts													
1	Patterns												
2	Cause and effect: Mechanism and explanation												
3	Scale, proportion, and quantity												
4	Systems and system models												
5	Energy and matter: Flows, cycles, and conservation												
6	Structure and Function												
7	Stability and change												
Science and Engineering Practices													
1	Asking questions and Defining Problems												
2	Developing and using models												
3	Planning and carrying out investigations												
4	Analyzing and interpreting data												
5	Using mathematics, Informational and Computer Technology, and computational thinking												
6	Constructing explanations and designing solutions												
7	Engaging in argument from evidence												
8	Obtaining, evaluating, and communicating information												

Objective Number	Common Core State Standards ● = Fully covered ◐ = Partially covered	Simple Machines														
		Gears			Wheels and Axles			Levers			Pulleys					
		1. Principle Models: Gears	2. Main Activity: Merry-Go-Round	3. Problem-Solving Activity: Popcorn Cart	1. Principle Models: Wheels and Axles	2. Main Activity: Go-Cart	3. Problem-Solving Activity: Wheelbarrow	1. Principle Models: Levers	2. Main Activity: Catapult	3. Problem-Solving Activity: Railroad Crossing Gate	1. Principle Models: Pulleys	2. Main Activity: Crazy Floors	3. Problem-Solving Activity: Crane			
Mathematical Practice																
MP1	Make sense of problems and persevere in solving them.	◐	●	●	◐	●	●	◐	●	●	◐	●	●	◐	●	●
MP2	Reason abstractly and quantitatively.			●		●	●		●	●						◐
MP3	Construct viable arguments and critique the reasoning of others.		●	●		◐	◐		●	●		●	●		●	●
MP4	Model with mathematics.	●			●	●			●			●				
MP5	Use appropriate tools strategically.	●	●	●	●	●	◐		●	●	●	●	●	●	●	●
MP6	Attend to precision.	●	●	●	●	●	●		●	●	●	●	●	●	●	●
MP7	Look for and make use of structure.		●	●	◐	●	●		◐	●	●	◐	●	●		●
MP8	Look for and express regularity in repeated reasoning.	◐		◐		●					●				◐	
Measurement & Data																
3.MD.B.4	Generate measurement data by measuring lengths					●	●		●							
4.MD.A.2	Use the four operations to solve word problems involving distance.					◐	◐		◐							
Writing Standards																
W.3.2	Write informative/explanatory texts to examine a topic and convey ideas and information clearly.	●	●		●	●		●	●		●	●		●	●	
W.3.7	Conduct short research projects that build knowledge about a topic.			●				●			●			●		●
W.3.8	Recall information from experiences or gather information from print and digital sources; take brief notes on sources and sort evidence into provided categories.			◐				◐			◐			◐		◐
W.4.2	Write informative/explanatory texts to examine a topic and convey ideas and information clearly.	●	●		●	●		●	●		●	●		●	●	
W.4.7	Conduct short research projects that build knowledge through investigation of different aspects of a topic.			●				●			●			●		●
W.4.8	Recall relevant information from experiences or gather relevant information from print and digital sources; take notes and categorize information, and provide a list of sources.			◐				◐			◐			◐		◐
W.5.2	Write informative/explanatory texts to examine a topic and convey ideas and information clearly.	●	●		●	●		●	●		●	●		●	●	
W.5.7	Conduct short research projects that use several sources to build knowledge through investigation of different aspects of a topic.			●				●			●			●		●
W.5.8	Recall relevant information from experiences or gather relevant information from print and digital sources; summarize or paraphrase information in notes and finished work, and provide a list of sources.			◐				◐			◐			◐		◐

Objective Number	<p>Common Core State Standards</p> <p>● = Fully covered ● = Partially covered</p>	Simple Machines											
		Gears			Wheels and Axles			Levers			Pulleys		
		1. Principle Models: Gears	2. Main Activity: Merry-Go-Round	3. Problem-Solving Activity: Popcorn Cart	1. Principle Models: Wheels and Axles	2. Main Activity: Go-Cart	3. Problem-Solving Activity: Wheelbarrow	1. Principle Models: Levers	2. Main Activity: Catapult	3. Problem-Solving Activity: Railroad Crossing Gate	1. Principle Models: Pulleys	2. Main Activity: Crazy Floors	3. Problem-Solving Activity: Crane
Speaking and Listening													
SL.3.1	Engage effectively in a range of collaborative discussions (one-on-one, in groups, and teacher-led) with diverse partners on grade 3 topics and texts, building on others' ideas and expressing their own clearly.	●	●	●	●	●	●	●	●	●	●	●	●
SL.3.3	Ask and answer questions about information from a speaker, offering appropriate elaboration and detail.	●	●	●	●	●	●	●	●	●	●	●	●
SL.3.4	Report on a topic or text, tell a story, or recount an experience with appropriate facts and relevant, descriptive details, speaking clearly at an understandable pace.	●	●	●	●	●	●	●	●	●	●	●	●
SL.4.1	Engage effectively in a range of collaborative discussions (one-on-one, in groups, and teacher-led) with diverse partners on grade 4 topics and texts, building on others' ideas and expressing their own clearly.	●	●	●	●	●	●	●	●	●	●	●	●
SL.4.3	Identify the reasons and evidence a speaker provides to support particular points.	●	●	●	●	●	●	●	●	●	●	●	●
SL.4.4	Report on a topic or text, tell a story, or recount an experience in an organized manner, using appropriate facts and relevant, descriptive details to support main ideas or themes; speak clearly at an understandable pace.		●	●		●	●		●	●		●	●
SL.5.1	Engage effectively in a range of collaborative discussions (one-on-one, in groups, and teacher-led) with diverse partners on grade 5 topics and texts, building on others' ideas and expressing their own clearly.	●	●	●	●	●	●	●	●	●	●	●	●
SL.5.3	Summarize the points a speaker makes and explain how each claim is supported by reasons and evidence.		●	●		●	●		●	●		●	●
SL.5.4	Report on a topic or text or present an opinion, sequencing ideas logically and using appropriate facts and relevant, descriptive details to support main ideas or themes; speak clearly at an understandable pace.		●	●		●	●		●	●		●	●
SL.5.5	Include multimedia components (e.g., graphics, sound) and visual displays in presentations when appropriate to enhance the development of main ideas or themes.			●		●			●			●	

Overview: Gears

Spur Gears

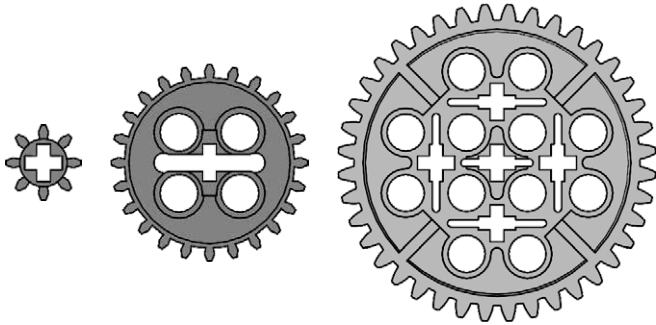

A Crown Gear

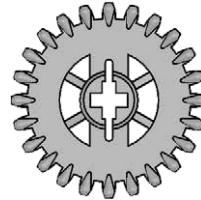

A gear is most commonly defined as a toothed wheel; the teeth of a gear prevent slipping. When one gear is engaged with another gear they are said to mesh. When a set of gears work together they transmit movement and force. A crown gear has special curved teeth that enable it to mesh at right angles with a spur gear. Gears are sometimes categorized as compound machines, but in this material we have included them as simple machines.

Gears can be used to create the following effects:

- To change the direction of rotation
- To change the orientation of a rotating movement
- To increase or decrease the speed of rotation
- To increase turning force, also called torque

Gears are found in many machines where there is a need to control the speed of rotary movement and turning force. Examples include cars, bicycles, old-fashioned egg beaters, can openers, and grandfather clocks.

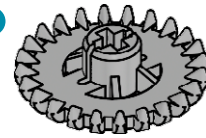

Did you know?

A gear, or toothed wheel, when in operation, may actually be considered to be a lever, with the additional feature that it can be rotated continuously instead of rocking back and forth through a short distance.

Establishing the Concept

We recommend establishing the concept of the simple machine to be worked on. This could be done, for example, by showing students a number of exhibits from the LEGO® set to stimulate their interest. Build a principle model, or show some of the images from Images for Classroom Use, asking questions such as “What do you know about this simple machine?” or “Where do we use this simple machine?” See if students can name any of the objects you show them, and allow time for students to handle them.

Providing the Vocabulary

Students will acquire the necessary vocabulary for the simple machine as they progress through the activities, but it may be useful to introduce certain terms at this stage. Important new vocabulary items are *drive gear* and *driven gear*.

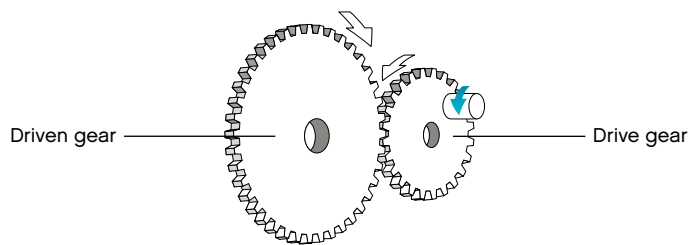

The gear that is closer to the source of power is called the drive gear and the gear that receives power from the drive gear is called the driven gear (or follower gear).

Understanding the Principles

The principle models are designed to help students understand the principles of the simple machine in focus through hands-on experience before they move on to construct the main models.

The principle models are presented in a logical sequence that will build on students' understanding. The principle models can only be built one at a time from the parts in the set.

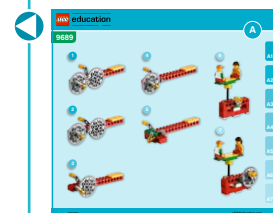
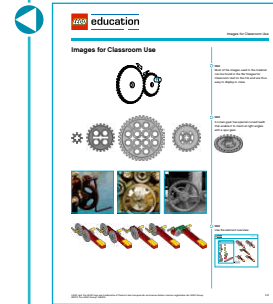
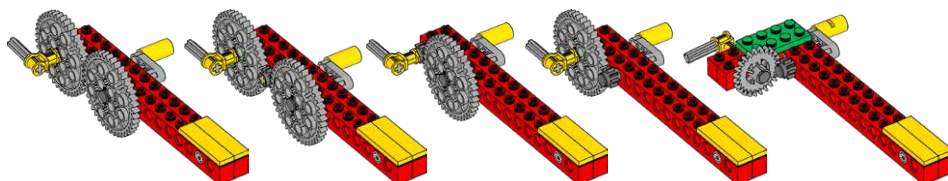

Using the Principle Models

1. The yellow elements indicate where to hold, push, lift, or apply force/effort in handling the principle models. The principle models need to be held correctly for them to work properly.
2. When measuring one turn of the handle, carefully observe the starting place of the handle, and be careful to stop at the same position after a full turn.
3. When measuring a full turn of the position marker, carefully observe the starting place of the position marker, and be careful to stop at the same position after a full turn. This is especially important when observing the connection between cranking the handle and the number of turns the position marker makes.

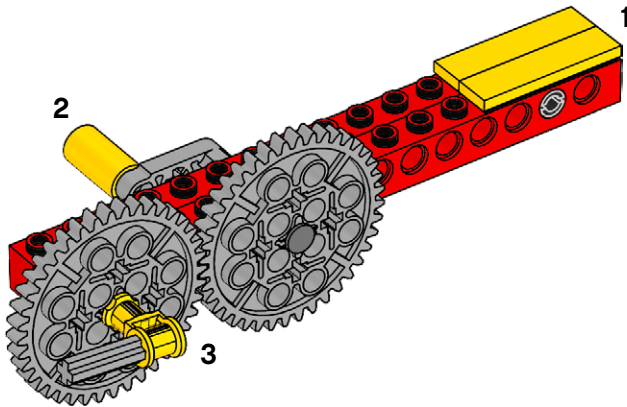

Hint

The principle models can be built as mirror-images for left-handed students.

Hint

It is recommended that students work in pairs; one student can observe the position marker while the other cranks the handle a full turn.

Images for Classroom Use

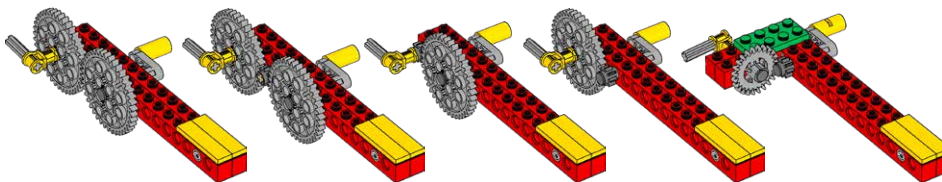
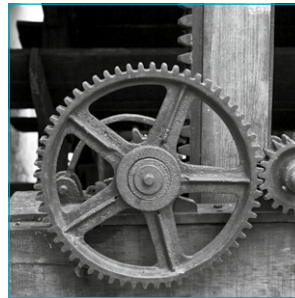
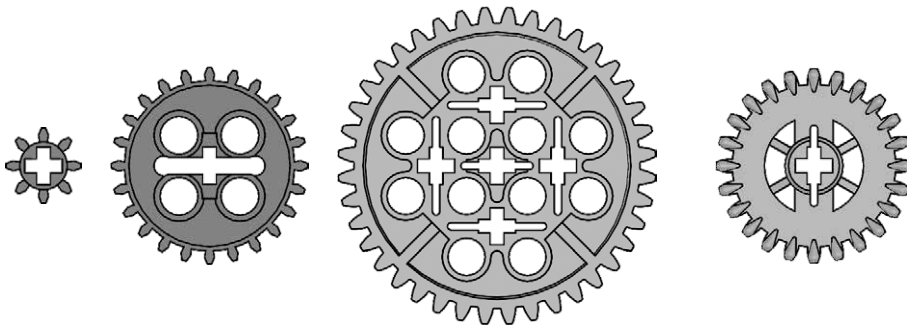
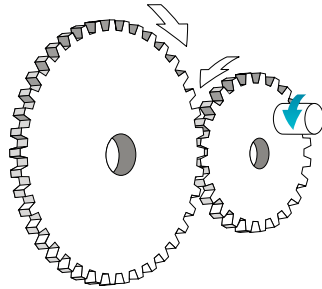

Hint

Hint

Most of the images used in the material can be found in the section "Images for Classroom Use" and are easy to display in class.

Hint

A crown gear has special curved teeth that enable it to mesh at right angles with a spur gear.

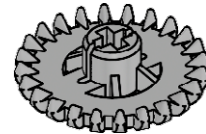

Hint

Use the element overview.

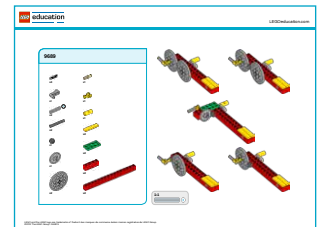

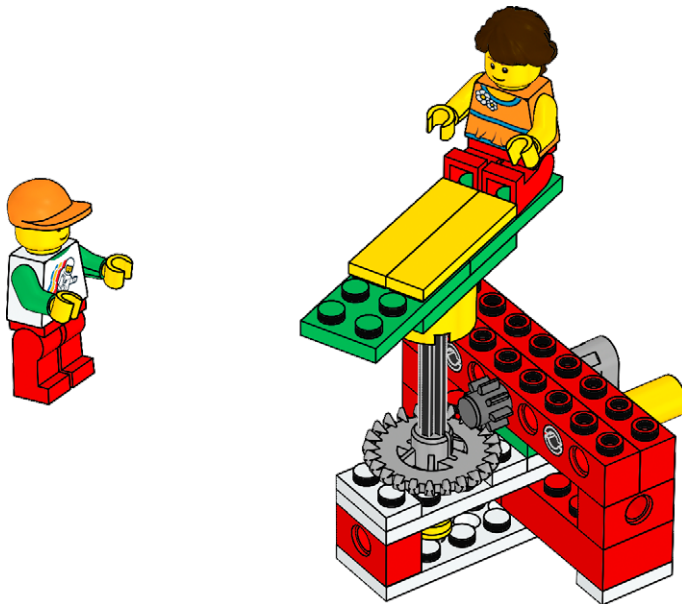

Hint

It is often more practical to sort out the elements that will be needed before starting work on the models.

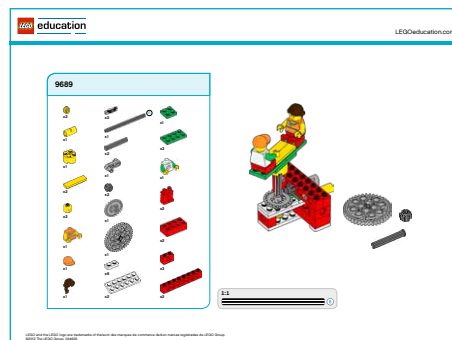
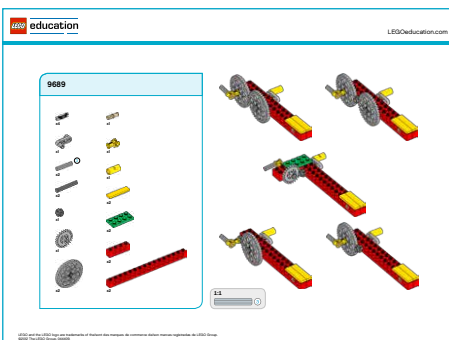

Hint

The element overview can be printed and used as a checklist for students to use when they are taking out and putting away their elements.

Principle Models: Gears

Teacher's Notes

Things to talk about:

- What do you know about this simple machine?
- Where do we use this simple machine?
- Why do we use this simple machine?

Relate students' answers to some of the images from "Images for Classroom Use" or find ideas from the "Overview: Gears" section to stimulate students' interest.

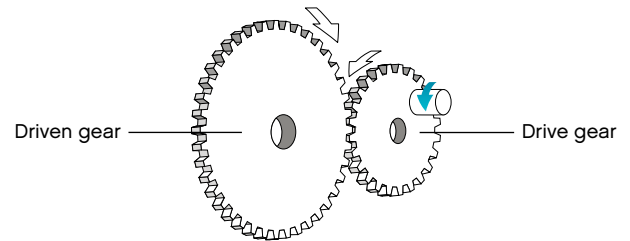

Find the LEGO® gears shown and count the number of teeth they each have. Start counting from the dot.

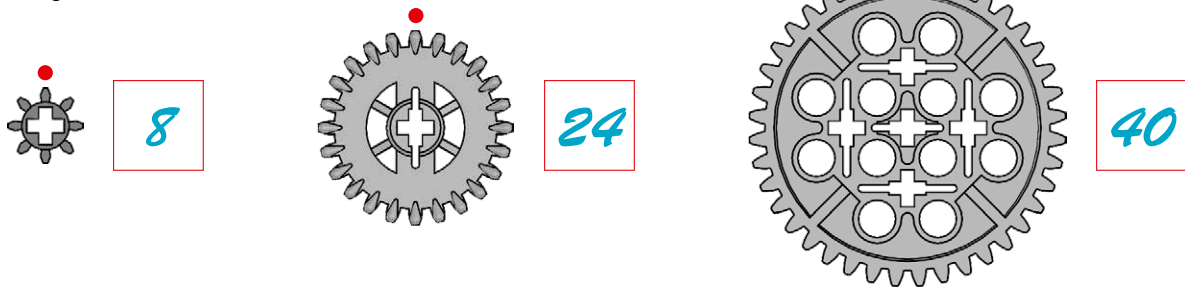

1. Build A1 (Direction of rotation).

Follow Building Instructions A, pages 4 to 8, steps 1 to 7.

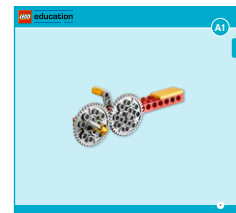

2. Label the gears.

Draw lines from the words to the picture of the model.

The drive gear is the gear that is turned by an outside effort, in this case your hand. Any gear that is turned by another gear is called the driven gear or follower.

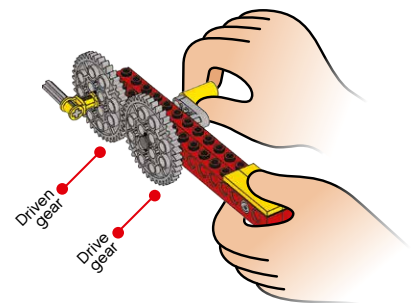

3. Try out the model and make observations.

Note: It is recommended that students work in pairs; one student can observe the position marker while the other cranks the handle a full turn.

Crank the handle one full turn, and count how many times the position marker turns. One turn of the handle results in one turn of the position marker (the gray axle). The speeds of rotation of the drive and the driven gears are the same, because they have the same number of teeth (40); this ratio is 1:1.

Observe which way the gears turn when you crank the handle, and draw arrows to show the directions they turn in.

Adjacent gears turn in opposite directions.

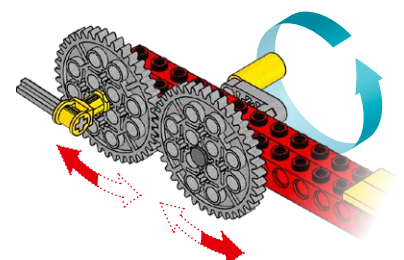

1. Build A2 (Idler gearing).

Follow Building Instructions A, pages 10 to 14, steps 1 to 8.

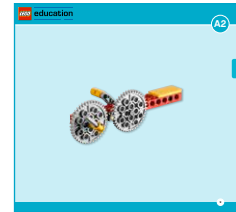

2. Label the gears.

Draw lines from the words to the picture of the model.

The small gear is an idler gear. The idler gear does not affect the relative speeds of rotation of either of the larger gears, only the direction in which the driven gear turns.

3. Try out the model and make observations.

Crank the handle one full turn, and count how many times the position marker turns.

One turn of the handle results in one turn of the gray axle. The speeds of rotation of the drive and the driven gears are the same, because they have the same number of teeth. The gearing ratio is 1:1.

Observe which way the gears turn when you crank the handle, and draw arrows to show the directions they turn in.

The 40-tooth drive gear and the 40-tooth driven gear both turn in the same direction. The idler gear rotates in the opposite direction.

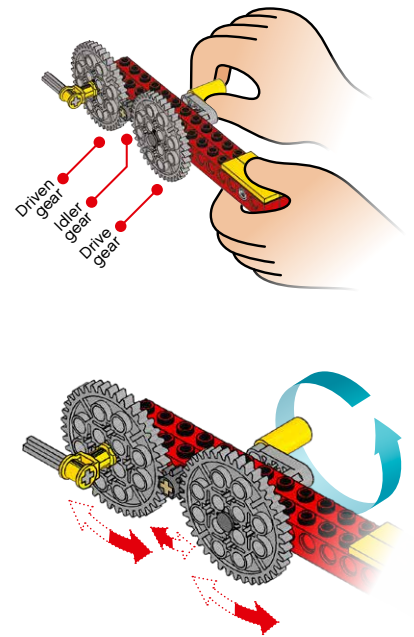

1. Build A3 (Increasing speed of rotation).

Follow Building Instructions A, pages 16 to 20, steps 1 to 7.

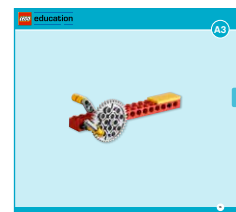

2. Label the gears.

Draw lines from the words to the picture of the model.

The drive gear is the gear that is turned by an outside effort, in this case your hand. Any gear that is turned by another gear is called a driven gear or follower.

3. Try out the model and make observations.

Crank the handle one full turn, and count how many times the position marker turns.

One turn of the handle (the large drive gear) results in five turns of the smaller driven gear. This ratio of 1:5 (or 1/5) is called the gearing up ratio ($8/40 = 1/5$). Increasing the gearing up ratio increases the speed of rotation of the driven gear, but decreases the force in the driven gear—the power of the gear to turn something.

Observe which way the gears turn when you crank the handle, and draw arrows to show the directions they turn in.

Adjacent gears turn in opposite directions.

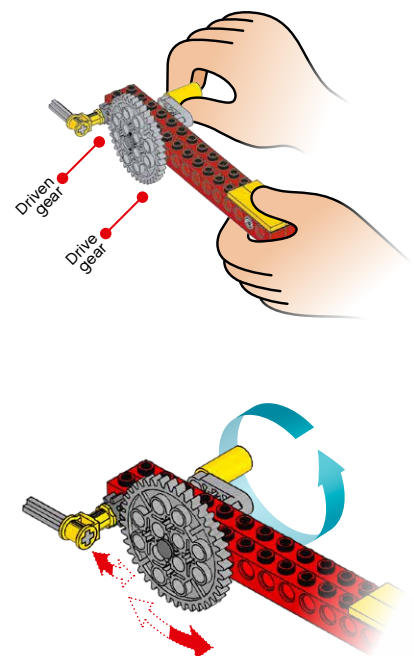

1. Build A4 (Decreasing speed of rotation).

Follow Building Instructions A, pages 22 to 26, steps 1 to 7.

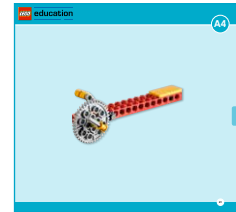

2. Label the gears.

Draw lines from the words to the picture of the model.

The drive gear is the gear that is turned by an outside effort, in this case your hand. Any gear that is turned by another gear is called a driven gear or follower.

3. Try out the model and make observations.

Count how many times the handle has to turn for the position marker to turn once.

Five turns of the handle (the small drive gear) results in one turn of the large driven gear. This ratio of 5:1 (or 5/1) is called the gearing down ratio ($40/8 = 5/1$). Decreasing the gearing ratio decreases the speed of rotation of the driven gear, but increases the force in the driven gear—the power of the gear to turn something.

Observe which way the gears turn when you crank the handle, and draw arrows to show the directions they turn in.

Adjacent gears turn in opposite directions.

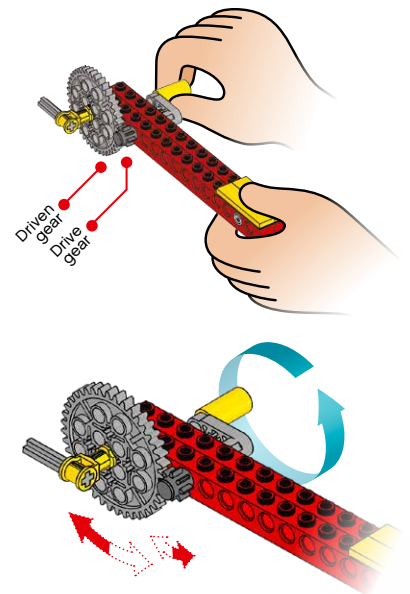

1. Build A5 (At an angle).

Follow Building Instructions A, pages 28 to 32, steps 1 to 8.

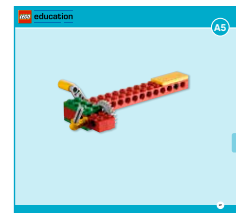

2. Label the gears.

Draw lines from the words to the picture of the model.

The 8-tooth drive spur gear moves the 24-tooth driven crown gear.

3. Try out the model and make observations.

Count how many times the handle has to turn for the position marker to turn once.

Three turns of the handle (the small drive gear) results in one turn of the crown gear. This is a ratio of 3:1 (or 24/8 or 3/1).

Observe which way the gears turn when you crank the handle, and draw arrows to show the directions they turn in.

The rotary motion is changed through a 90-degree angle/turns through an angle/turns a corner (the answer your students give will depend on their familiarity with describing angles). The crown gear can change the rotary motion easily because it has special curved teeth that enable it to mesh at an angle/at right angles in a different direction with a spur gear.

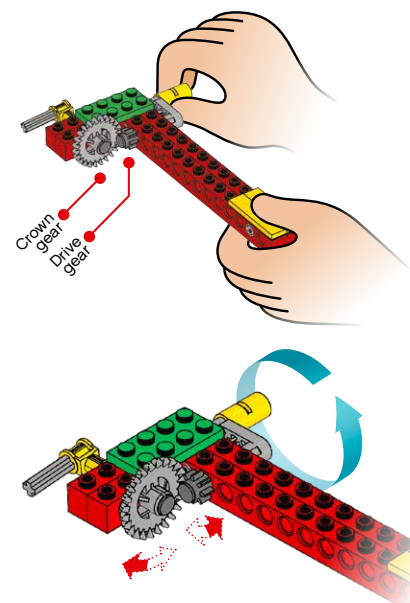

Name(s): _____

Date and subject: _____

Principle Models: Gears

Student Worksheet

Things to talk about:

- What do you know about this simple machine?
- Where do we use this simple machine?
- Why do we use this simple machine?

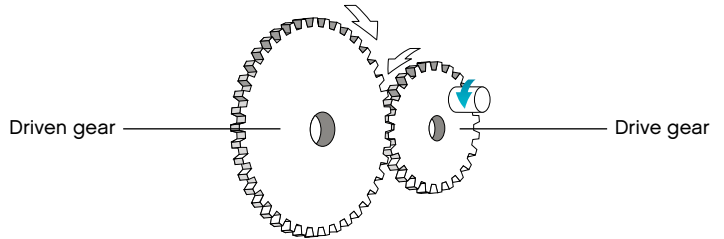

Find the LEGO® gears shown and count the number of teeth they each have. Start counting from the dot.

Write your answers in the boxes.

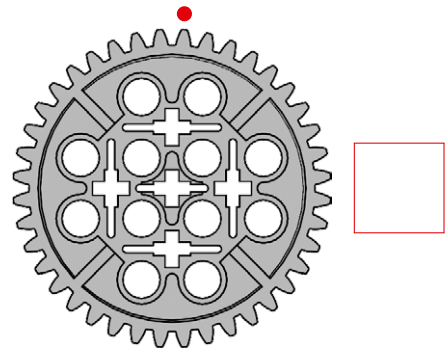
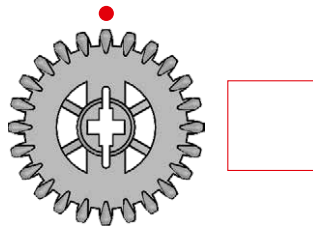
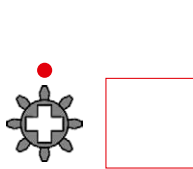

1. **Build A1** (Direction of rotation).
Follow Building Instructions A, pages 4 to 8, steps 1 to 7.

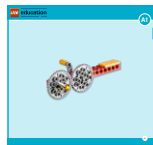

2. **Label the gears.**
Draw lines from the words to the picture of the model.



Driven gear ●
Drive gear ●

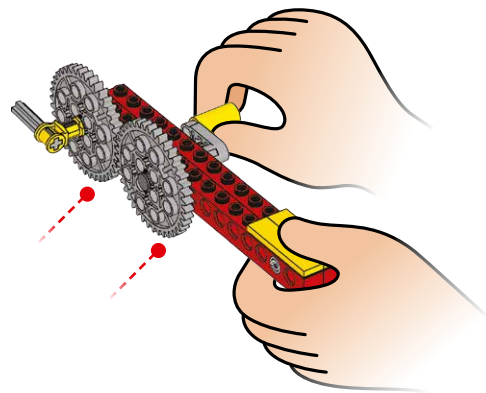

3. **Try out the model and make observations.**
Crank the handle one full turn, and count how many times the position marker turns.
Write your answer here:



.....



Observe which way the gears turn when you crank the handle, and draw arrows to show the directions they turn in.

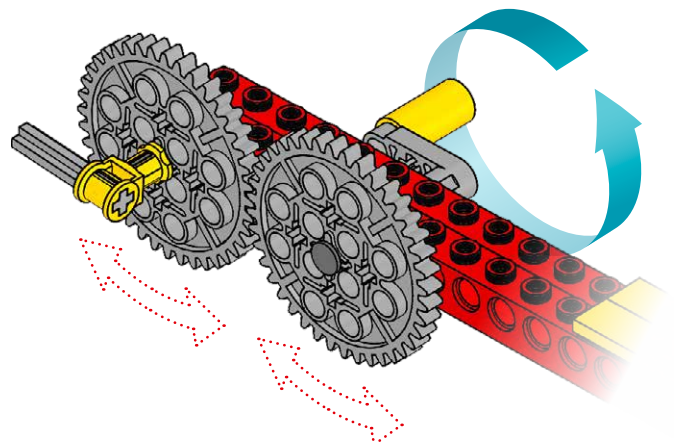

1. Build A2 (Idler gearing).

Follow Building Instructions A, pages 10 to 14, steps 1 to 8.

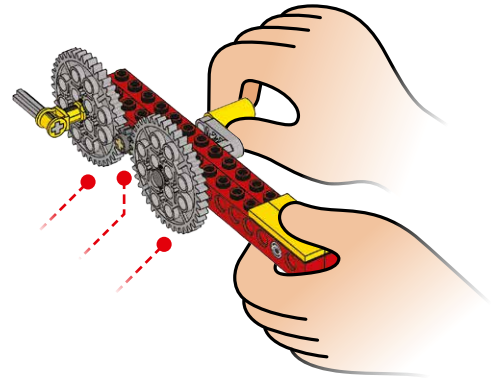

2. Label the gears.

Draw lines from the words to the picture of the model.



- Driven gear ●
- Idler gear ●
- Drive gear ●

3. Try out the model and make observations.

Crank the handle one full turn, and count how many times the position marker turns. Write your answer here:



.....

Observe which way the gears turn when you crank the handle, and draw arrows to show the directions they turn in.

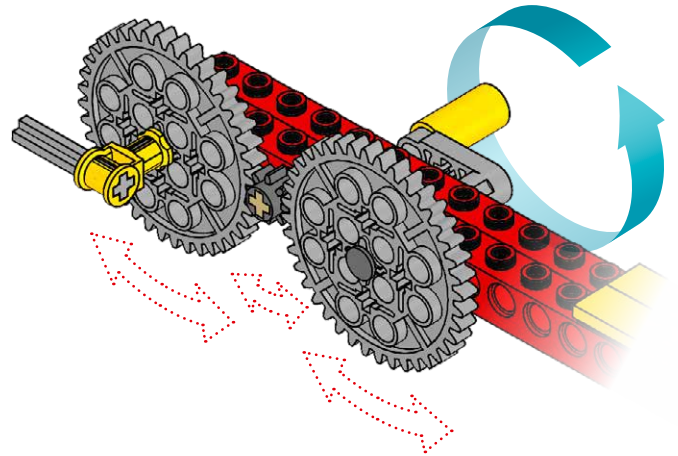

1. Build A3 (Increasing speed of rotation).

Follow Building Instructions A, pages 16 to 20, steps 1 to 7.

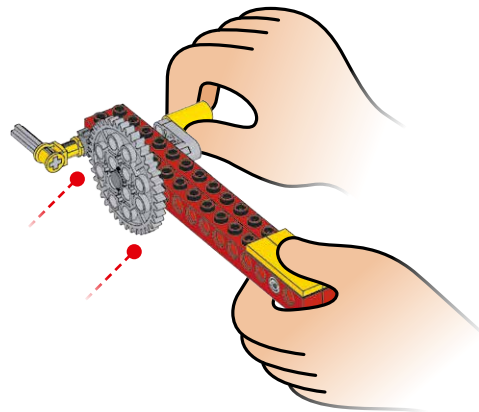
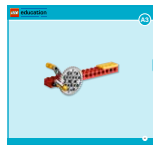

2. Label the gears.

Draw lines from the words to the picture of the model.



- Driven gear ●
- Drive gear ●

3. Try out the model and make observations.

Crank the handle one full turn, and count how many times the position marker turns. Write your answer here:



.....

Observe which way the gears turn when you crank the handle, and draw arrows to show the directions they turn in.

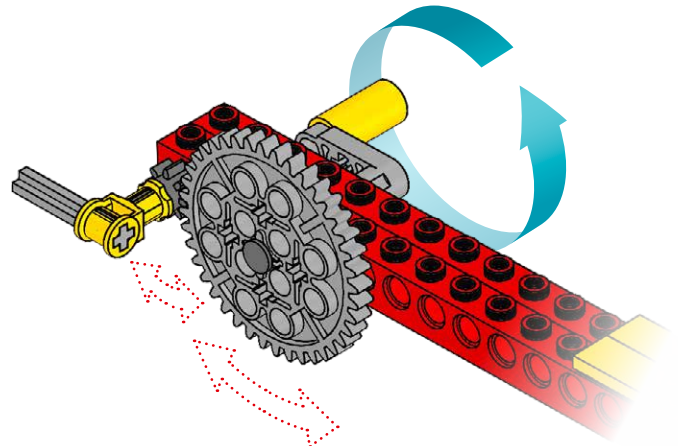

1. **Build A4** (Decreasing speed of rotation).
Follow Building Instructions A, pages 22 to 26, steps 1 to 7.



2. **Label the gears.**
Draw lines from the words to the picture of the model.

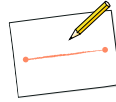

Driven gear ●
Drive gear ●

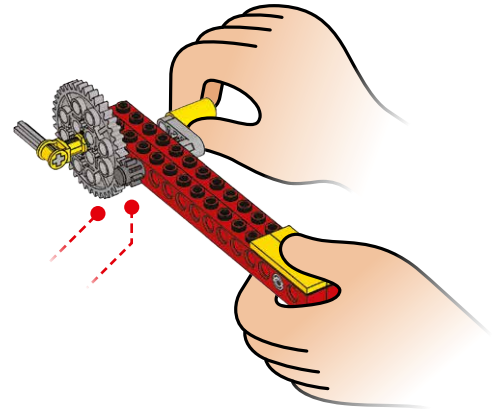

3. **Try out the model and make observations.**
Count how many times the handle has to turn for the position marker to turn once.
Write your answer here:



.....

Observe which way the gears turn when you crank the handle, and draw arrows to show the directions they turn in.

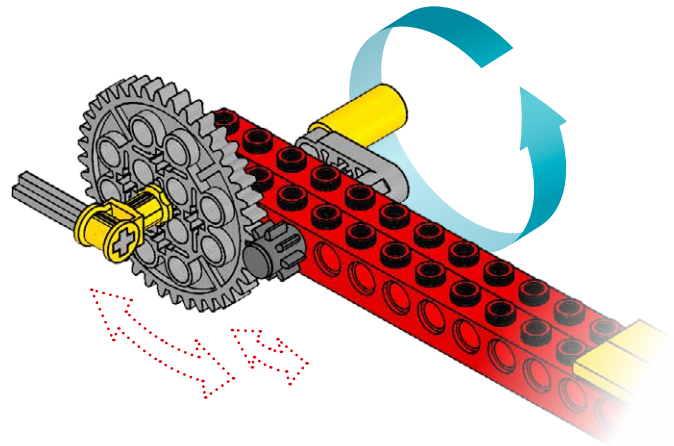

1. **Build A5** (At an angle).
Follow Building Instructions A, pages 28 to 32, steps 1 to 8.



2. **Label the gears.**
Draw lines from the words to the picture of the model.



Crown gear ●
Spur gear ●

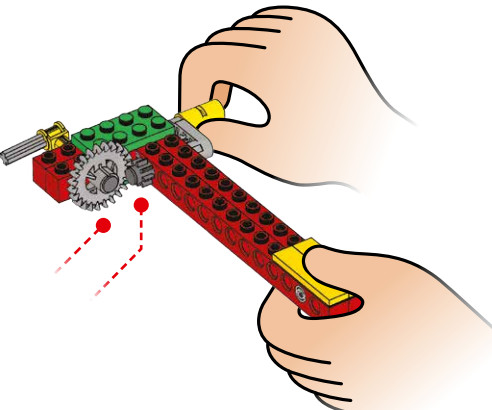

3. **Try out the model and make observations.**
Count how many times the handle has to turn for the position marker to turn once.
Write your answer here:



.....

Observe which way the gears turn when you crank the handle, and draw arrows to show the directions they turn in.

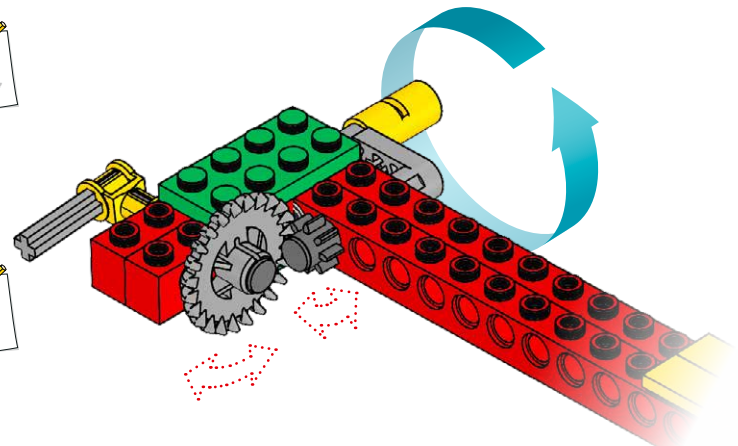

Main Activity: Merry-Go-Round

Teacher's Notes

Learning Objectives

In this activity students will build and test models that use the following techniques associated with gears:

- Decreasing speed of rotation
- Increasing speed of rotation
- Gearing at an angle

To perform this activity, students should be familiar with the following vocabulary associated with gears:

- Drive gear
- Driven gear
- To mesh

If students have already worked with the principle models, they will already have observed gears, and the terms used in this activity should be familiar to them. Predictions should now be easier to make based on the observations made earlier. If the students have not worked on the principle models, then additional time will be needed, for example to introduce and explain the technical vocabulary used. If additional guidance is required, please turn to the "Overview: Gears" or "Principle Models" sections.

Materials Required

- 9689 LEGO® Education Simple Machines Set

◀ 9689



Connect**Hint**

Most of the images used in the material can be found in the section "Images for Classroom Use", and are easy to display in class.

Sam and Sally love going to the fair. The ride they enjoy most is the merry-go-round. It's such fun to spin around and around, waving to their friends and families!

Do you like merry-go-rounds?
What do you enjoy most about them?
Which simple machine might be needed for a merry-go-round to turn?

Let's build a merry-go-round!

Construct

1. First, build Merry-Go-Round Model A6 and make it turn.

Follow Building Instructions A, pages 34 to 42, steps 1 to 11.

When Merry-Go-Round Model A6 has been built, check the following:

- *Crank the yellow handle to make sure the merry-go-round turns.*
- *Make sure the minifigure is attached securely. Students are welcome to use either Sam or Sally, but they should be told that it is easier to count how many times the merry-go-round makes a full turn with only one minifigure on the merry-go-round.*

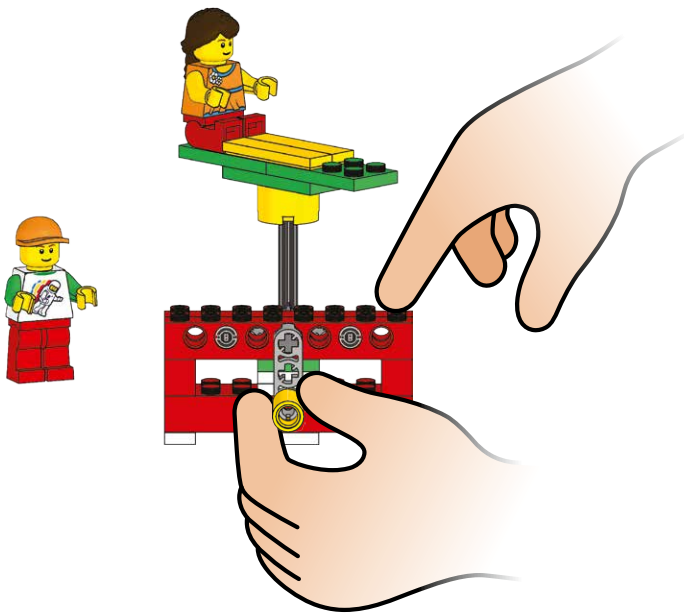

Hint

Students should be reminded that the drive gear is the gear turned by an outside effort, in this case your hand cranking the yellow handle.

Contemplate

2. Count the teeth on the gears. Start counting from the dot.

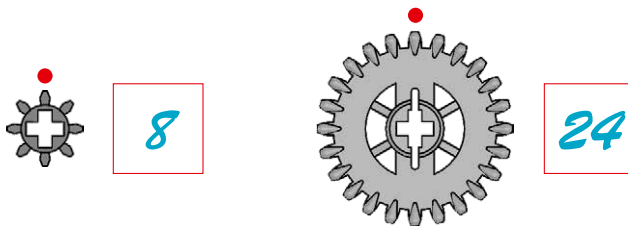

There are two gears used in model A6: a spur gear (8 teeth) and a crown gear (24 teeth).

3. Then look carefully at the pictures of the models and compare Merry-Go-Round Model A6 to Merry-Go-Round Model A7.

- Circle what is different.
- What do you notice? Explain how the models are different.

Students should notice the difference in both size and number of gears used on model A6 compared to model A7.

4. Next, look carefully at the pictures of the models and make a prediction.

If I compare model A6 to model A7, then I think Merry-Go-Round Model (A6/A7) will turn faster.

Encourage students to discuss the effects the different gearing has on the merry-go-rounds in their own words. For the prediction, the correct answer is model A7; however, it does not matter whether students get the answer right or wrong at this point, only that they should make a prediction that can be checked later.

5. Test Merry-Go-Round Model A6.

- If you want Sam or Sally to make a full turn, how many times must you crank the handle?

Have students observe the starting point of both the handle and the minifigure. Encourage them to try more than once, to ensure that their observations are correct. Students must write their answer on the student worksheet.

The students will have to crank the handle three times for Merry-Go-Round Model A6 to turn once. The gear ratio is 3:1; this is a gearing down arrangement (because $24/8 = 3/1$), and the merry-go-round turns slowly. Students should be made aware that the angled gearing enables the rotary motion to be transmitted through a 90-degree angle.

Note: If possible, keep an example of Merry-Go-Round Model A6 for students to compare with Merry-Go-Round Model A7.

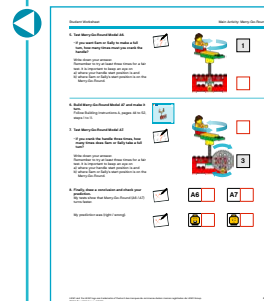
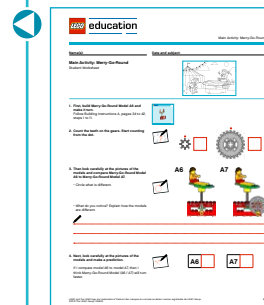

6. Build Merry-Go-Round Model A7 and make it turn.

Follow Building Instructions A, pages 44 to 52, steps 1 to 11.

Encourage students to identify the gears and count the teeth on the gears.

There are four gears used in the model: two small spur gears (8 teeth), a crown gear (24 teeth), and a large spur gear (40 teeth).

7. Test Merry-Go-Round Model A7.

- If you crank the handle three times, how many times does Sam or Sally make a full turn?

Have students pay attention to the starting positions of the handle and the minifigure as described earlier. Encourage them to try more than once, to ensure that their observations are correct.

Three turns of the 40-tooth gear produce five turns of the merry-go-round.

The gear ratio is 3:5 (because $24/40 = 3/5$), and the merry-go-round turns at a much faster pace.

8. Finally, draw a conclusion and check your prediction.

Merry-Go-Round Model A7 turns faster because of the gearing-up arrangement with the 40-tooth drive gear and the 24-tooth driven gear.

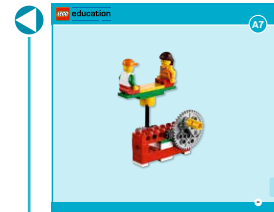
**Hint**

It is recommended that students work in pairs; one student can observe the minifigure while the other cranks the handle a full turn.

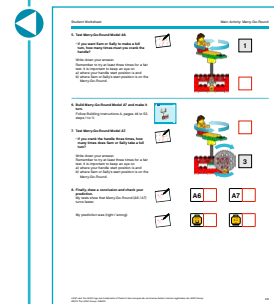

Continue

Students are encouraged to explore the gearings illustrated on the student worksheet and to record their observations.

Note: *There are no building instructions included to guide students through the Continue phase, other than the illustrated suggestions on the student worksheet.*

Encourage your students to discuss the effects that the gearing in focus will have on the merry-go-round in their own words, prompting them with questions such as:

- Describe what happened when you turned the handle.
- How many times did you have to turn the handle to make the merry-go-round turn once? Why do you think that was?
- Describe how the model works.
- What did you do to make sure your observations were correct?

It is suggested that students should draw a gear train (many gears meshing) or items where they find gears used in everyday machines and mechanisms. For inspiration, read or show the “Overview: Gears” section.

Optional

With more advanced students, you might consider introducing compound gearing or gear ratios. Ask what the gear ratio is, and how much faster or slower than the handle the merry-go-round will turn.

Hint

Most of the images used in the material can be found in the section “Images for Classroom Use”, and are easy to display in class.

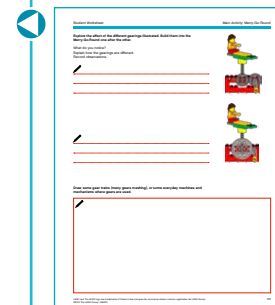

Merry-Go-Round

Class: _____

Date: _____

Performance and Learning Targets Linked to the Activity and the Eight Next Generation Science Practices	Name(s):											
<p>Observe the suggested student behaviors while working with the activity. Either use the suggested Emerging (E), Developing (D), Proficient (P), Accomplished (A) proficiency level descriptions or use one relevant to your context.</p>												
Student Performance Targets Linked to the Activity To what degree can the student...?												
Adequately build the Merry-Go-Round model(s) with help or independently using the Building Instruction (1, 2, 3, 6)												
Use the model to demonstrate and share understanding of science terms and make predictions about the use of different types of gears (E.g. crown gear, spur gear, driver gear, driven gear) (1, 3, 4, 5, 8)												
Use prior knowledge of fair rides to describe orally or in writing scientific problems that can be solved using different types of gears (1, 6, 8)												
Make changes or create a new model design in order to create a more advanced model based on tests and data (2, 3, 4, 6)												
Use Merry-Go-Round worksheets to record and analyze data collected from the model investigation (3, 4, 5)												
Selected Student Learning Targets Linked to the Practices To what degree can the student...?												
Ask questions and make observations about what would happen if a variable is changed (1, 3)												
Demonstrate ability to use fair testing of models and make adjustments based upon test data and measurements (3, 4, 6)												
Test different model designs of the same object to determine which one better meets the criteria (3)												
Estimate, collect, measure, describe and/or graph quantities to make comparisons across teams and listen to the ideas of others (4, 5, 6, 7, 8)												
Communicate the meaning of the findings with others (E.g. orally, in drawing or writing) (4, 8)												
Optional Student Learning Targets												
Lesson Observational Notes:												

Name(s): _____

Date and subject: _____

Main Activity: Merry-Go-Round

Student Worksheet



1. First, build Merry-Go-Round Model A6 and make it turn.

Follow Building Instructions A, pages 34 to 42, steps 1 to 11.



2. Count the teeth on the gears. Start counting from the dot.

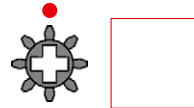

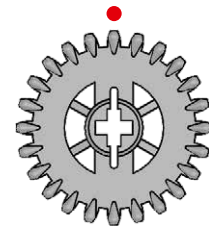

3. Then look carefully at the pictures of the models and compare Merry-Go-Round Model A6 to Merry-Go-Round Model A7.

• Circle what is different.



A6

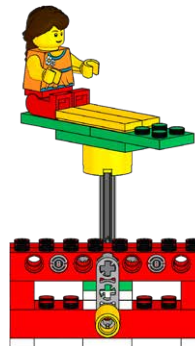

A7

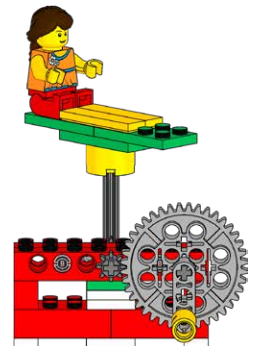

• What do you notice? Explain how the models are different.



.....

.....

.....

4. Next, look carefully at the pictures of the models and make a prediction.



A6	<input type="text"/>
----	----------------------

A7	<input type="text"/>
----	----------------------

If I compare model A6 to model A7, then I think Merry-Go-Round Model (A6 / A7) will turn faster.

5. Test Merry-Go-Round Model A6.

- If you want Sam or Sally to make a full turn, how many times must you crank the handle?

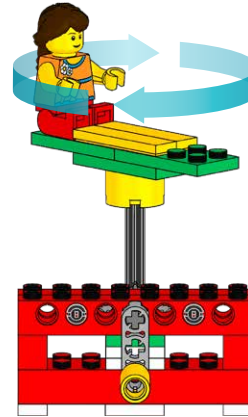

1

--

Write down your answer.
Remember to try at least three times for a fair test. It is important to keep an eye on
a) where your handle start position is and
b) where Sam or Sally's start position is on the Merry-Go-Round.

6. Build Merry-Go-Round Model A7 and make it turn.

Follow Building Instructions A, pages 44 to 52, steps 1 to 11.

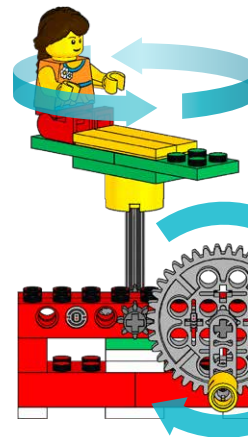
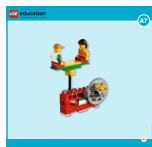

--

3

7. Test Merry-Go-Round Model A7.

- If you crank the handle three times, how many times does Sam or Sally take a full turn?



Write down your answer.
Remember to try at least three times for a fair test. It is important to keep an eye on
a) where your handle start position is and
b) where Sam or Sally's start position is on the Merry-Go-Round.

8. Finally, draw a conclusion and check your prediction.

My tests show that Merry-Go-Round (A6 / A7) turns faster.



A6	
-----------	--

A7	
-----------	--

My prediction was (right / wrong).



--	--

--	--

Explore the effect of the different gearings illustrated. Build them into the Merry-Go-Round one after the other.

What do you notice?
Explain how the gearings are different.
Record observations.



Three horizontal dotted lines for writing observations.

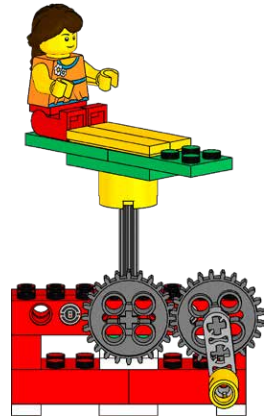

Three horizontal dotted lines for writing observations.

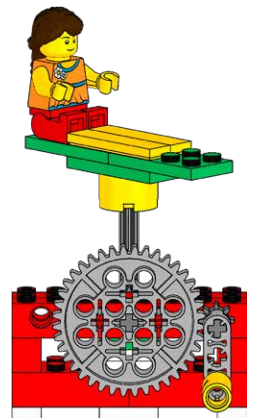

Draw some gear trains (many gears meshing), or some everyday machines and mechanisms where gears are used.



A large empty rectangular box for drawing gear trains or mechanisms.

Activity Name: _____

Student Name: _____

Date: _____

How did you do?

Directions: Circle the brick that shows how well you did. The bigger brick, the better you did.

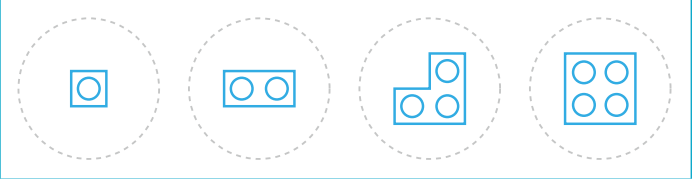
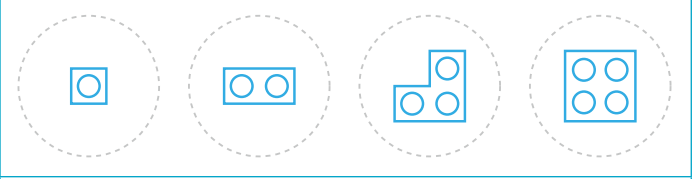
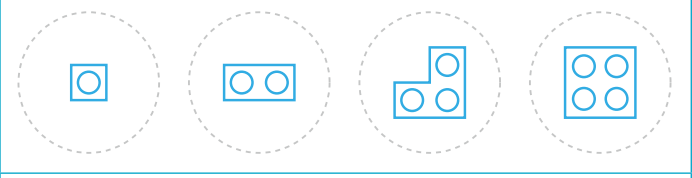
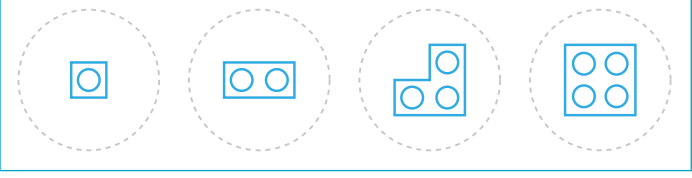
<p>I asked questions to understand what to do. I understood what to do.</p>	
<p>I made predictions and tested my model. I made observations and gathered data.</p>	
<p>I shared my ideas. I listened to my team.</p>	
<p>I used scientific words. I used fair testing.</p>	

Describe what you did (Draw, write or add a photo):

Tell someone what you learned...

Problem-Solving Activity: Popcorn Cart

Student Worksheet



When Sam and Sally visit the fair they always buy popcorn. Sometimes it can be difficult to see where popcorn is being sold. Sam and Sally want to help the popcorn seller by building a sign for the popcorn cart that will turn and attract people's attention.

Let's help Sam and Sally!

Build a popcorn cart like the one in the picture.

Your design brief is as follows:

- Build a popcorn cart.
- Make a sign that can turn.
- Build a mechanism that makes the sign turn when you turn a handle.

When you have finished, test your cart. Count how many times the sign spins for every five turns of the handle. Assess how easily the sign can be read at a distance. What makes it easy or difficult to read?

Need help?
Look at:

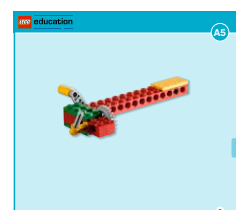
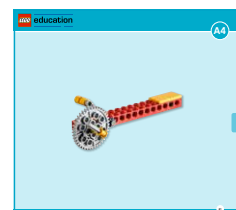
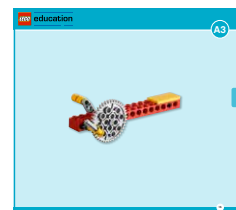
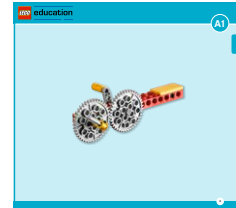

Activity Name: _____

Student Name: _____

Date: _____

How did you do?

Directions: Circle the brick that shows how well you did. The bigger brick, the better you did.

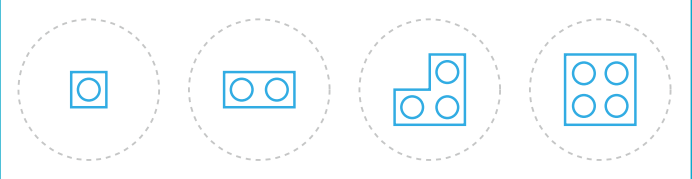
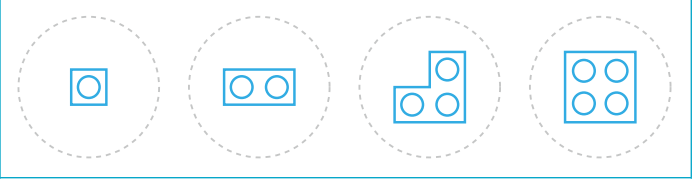
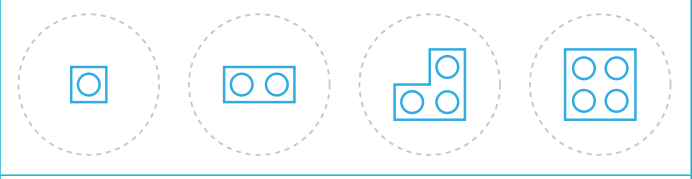
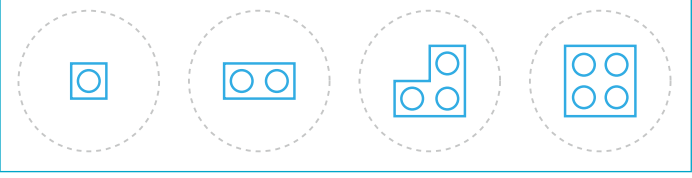
<p>I read the Design Brief. I understood the problem.</p>	
<p>I built a model to solve the problem. I tested the model and made improvements.</p>	
<p>I shared my ideas. I listened to my team.</p>	
<p>I used scientific words. I can do engineering and design.</p>	

Describe what you did (Draw, write or add a photo):

Tell someone about the problem you solved...

Problem-Solving Activity: Popcorn Cart

Teacher's Notes

Learning objectives:

Students are encouraged to do some research related to the real-life problem they are set to solve and/or the type of simple machine that they are going to use, and to:

- Identify a need or a problem
- Develop explanations using observations
- Test, evaluate, and redesign models

Introduction

To help in the design process, instruct the students to look at the picture on the student worksheet and read the accompanying text. If time and facilities are available, have your students conduct research, and also encourage them to generate ideas and questions by posing problems they must take into account in their design and building processes. Your students could search the Internet to learn more about the appearance, structure, and function of different sorts of carts and signs.

Students should be reminded of the principle models that they have worked with. It might be a good idea to build principle model A5 (At an angle) to show the technique used.

Discuss the design problem specified in the design brief in class. Try to find several possible general solutions, or use the suggested solution for inspiration if necessary.

Discuss the constraints and functions your students will have to take into account to carry out the design brief. Try to get your students to focus on relevant issues and decisions by asking questions. These might include:

- How will your model look?
Maybe a popcorn handcart with wheels, handles for pushing it, and a space for the popcorn, with a rotating sign on top operated by turning a handle. Or maybe simply a sign with a turning mechanism.
- What LEGO® elements do you have available? Which wheels will you use? What can you use for a sign? How do you think you might start building?
- Should your sign turn quickly or slowly, do you think? Why?

Optional Materials

Materials for enhancing the appearance and functionality of the model: Students can use paper, cardboard, and markers to make signs. Additional LEGO® elements, if available, may be used to make models more elaborate.

When the model is finished, encourage students to reflect on both the product that they have produced and the processes they have used by:

- Carrying out tests to evaluate the performance of their model
- Reflecting on the design brief
- Recording their design by drawing or taking digital photos

Hint

Most of the images used in the material can be found in the section "Images for Classroom Use", and are easy to display in class.

Need help?

Look at:

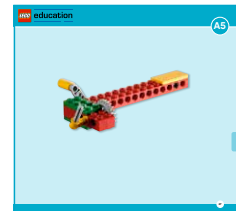

Suggested Model Solution

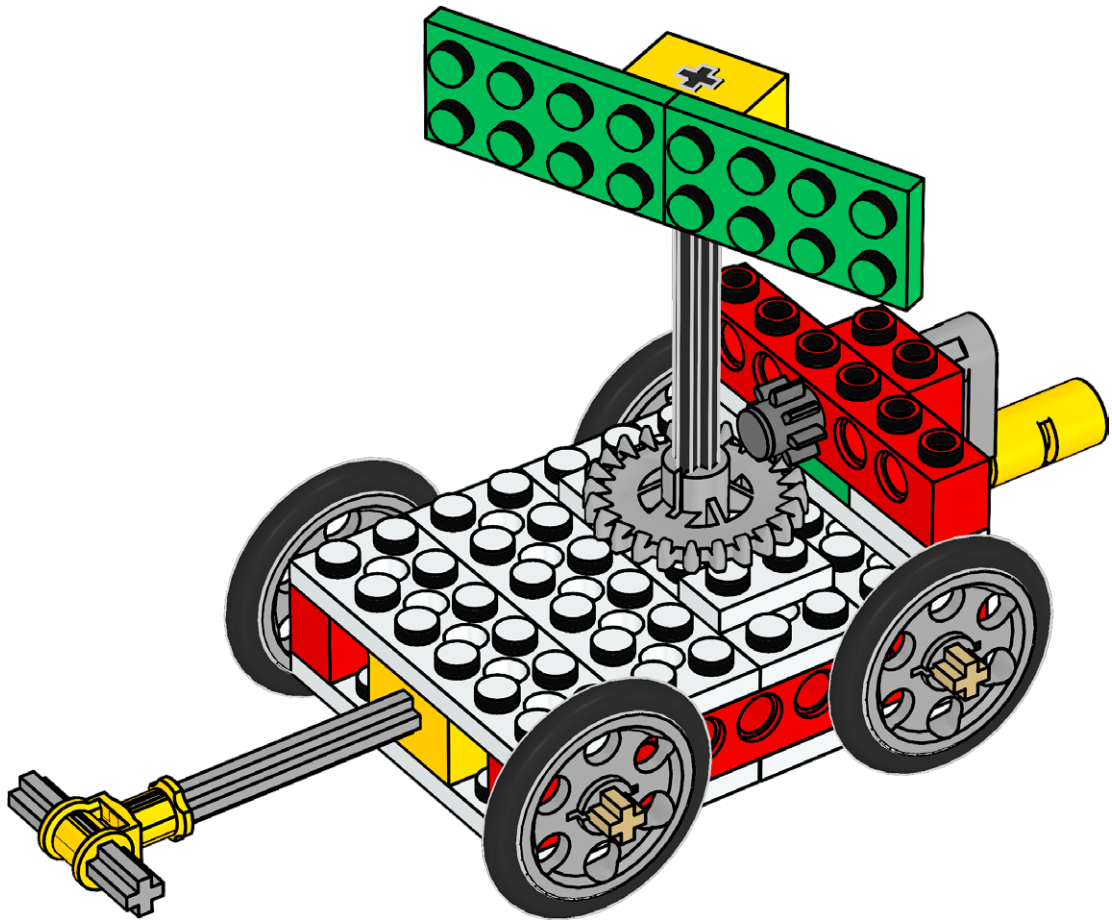

Popcorn Cart

Class: _____

Date: _____

Performance and Learning Targets Linked to the Activity and the Eight Next Generation Science Practices Observe the suggested student behaviors while working with the activity. Either use the suggested Emerging (E), Developing (D), Proficient (P), Accomplished (A) proficiency level descriptions or use one relevant to your context.	Name(s)														
Student Performance Targets Linked to the Activity To what degree can the student...?															
Plan, develop a design, and build a popcorn cart that meets or exceeds the Design Brief criteria based upon research (E.g. Sign can turn using a handle) (1, 2, 8)															
Design and compare multiple solutions to solve the problem and demonstrate understanding of cause and effect of design systems (2, 6)															
Record findings with drawings or digitally to share design ideas with others (2, 5, 7, 8)															
Evaluate and make changes to the model based upon observations and data using fair testing (1, 3, 4, 5, 8)															
Compare models to determine the best solution to the problem (6, 7)															
Selected Student Learning Targets Linked to the Practices To what degree can the student...?															
Ask questions and make observations about what would happen if a variable is changed (1, 3)															
Apply scientific ideas to solve design problems (6)															
Estimate, collect, measure, describe and/or graph quantities to make comparisons across teams and listen to the ideas of others (4, 5, 6, 7, 8)															
Communicate the meaning of the findings with others (E.g. orally, in drawing or writing) (4, 8)															
Discuss evidence that shows how the solution meets the criteria and constraints of the problem (7)															
Optional Student Learning Targets															
Lesson Observational Notes:															

Overview: Wheels and Axles

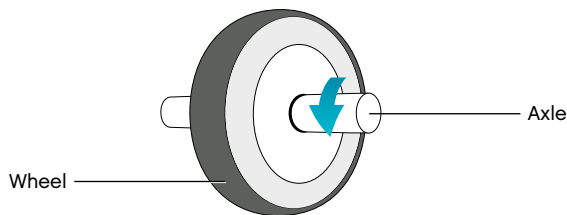

A wheel is most commonly defined as a solid disk or as a circular ring with spokes, designed to turn around a smaller axle (a rod) passing through its center. The circle traced in the air by a crank handle is also a wheel. As the crank handle goes round, the crank turns an attached axle. The wheel and attached axle both turn at the same speed. However, the force needed to turn one or the other differs, because the diameter of the wheel is larger than that of an axle. Applying a small force to turn the larger wheel produces a larger force to turn the smaller axle, as in a winch, for example.

Wheels and axles can be used to create the following effects:

- To control the direction of movement
- To increase turning force, also called torque
- To reduce friction and to make objects easy to move

Wheels and axles are found in many machines where there is a need to control the direction of movement and turning force, such as windmills, bicycles, roller skates, vehicles, rolling pins, helicopters, fishing reels, trolleys, strollers and door knobs.



Did you know?

A disk is only a wheel when an axle runs through it.

Establishing the Concept

We recommend establishing the concept of the simple machine to be worked on. This could be done, for example, by showing students a number of exhibits from the LEGO® set to stimulate their interest. Build a principle model, or show some of the images from Images for Classroom Use, asking questions such as “What do you know about this simple machine?” or “Where do we use this simple machine?” See if students can name any of the objects you show them, and allow time for students to handle them.

Providing the Vocabulary

Students will acquire the necessary vocabulary for the simple machine as they progress through the activities, but it may be useful to introduce one important term at this stage, namely *friction*.

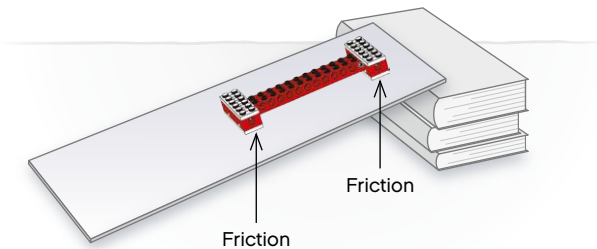

Friction is the resistance met when one surface slides over another; this affects movement (see the “Glossary” section). The effects of friction can be tested using the principle models.

Understanding the Principles

The principle models are designed to help students understand the principles of the simple machine in focus through hands-on experience before they move on to construct the main models.

The principle models are presented in a logical sequence that will build on students’ understanding. The principle models can only be built one at a time from the parts in the set.

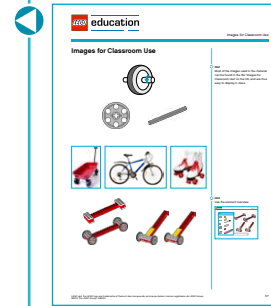
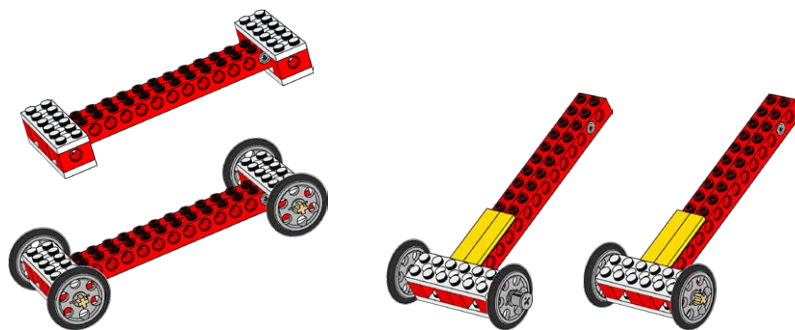

Hint

To introduce the term, it may be useful to bring some rough and smooth objects into class and show that it is harder to slide two rough objects over each other than two smooth objects.

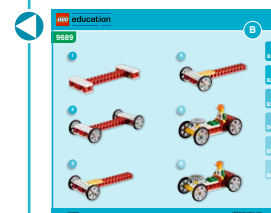

Using the Principle Models

1. The yellow elements indicate where to hold, push, lift, or apply force/effort in handling the principle models. The principle models need to be held correctly for them to work properly.

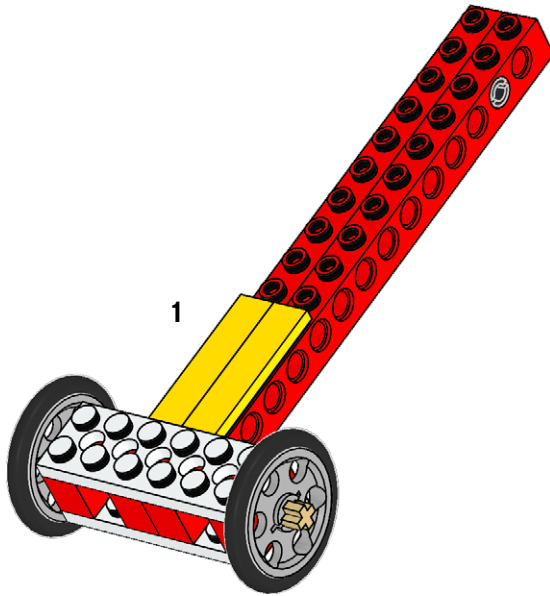

2. It is important for students to understand what friction is before working with the wheel and axle principle models. Friction makes a moving object tend to slow down and eventually stop unless additional force is applied, e.g., when two objects move against each other.

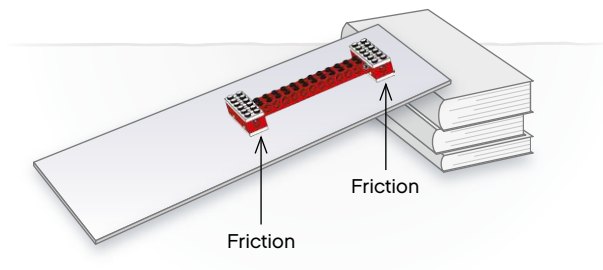

3. A ramp will be needed to test the first two principle models, B1 the sliding model and B2 the rolling model. Build a simple ramp by using books for height and a plank of wood or piece of stiff cardboard for the ramp.

Images for Classroom Use

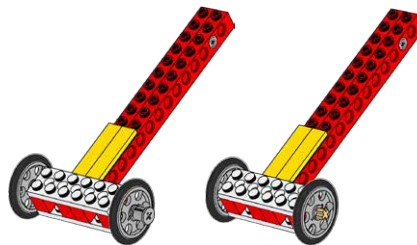
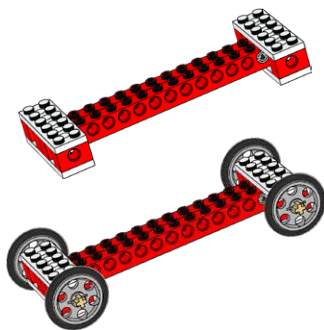
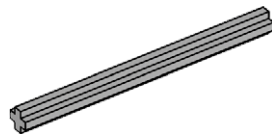
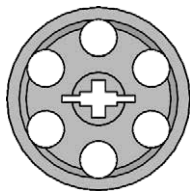
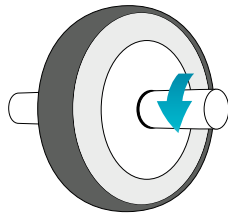

Hint

Most of the images used in the material can be found in the section "Images for Classroom Use", and are easy to display in class.

Hint

Use the element overview.

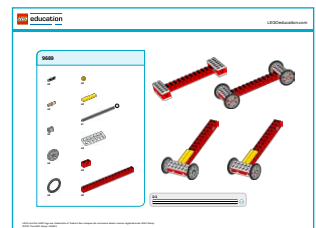

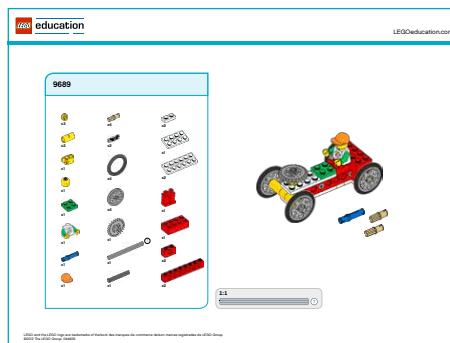
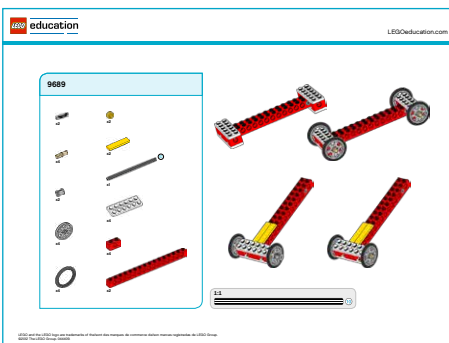
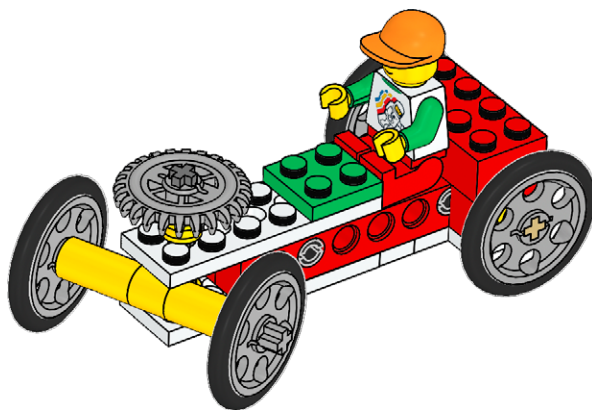

Hint

It is often more practical to sort out the elements that will be needed before starting work on the models.

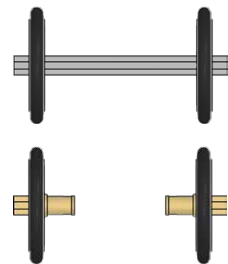

Hint

The element overview can be printed and used as a checklist for students to use when they are taking out and putting away their elements.

Principle Models: Wheels and Axles

Teacher's Notes

Things to talk about:

- What do you know about this simple machine?
- Where do we use this simple machine?
- Why do we use this simple machine?

Relate students' answers to some of the images from "Images for Classroom Use" or find ideas from the "Overview: Wheels and Axles" section to stimulate students' interest.

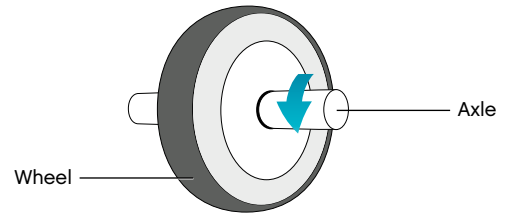

Build a ramp to test the first two principle models B1, B2.

Build a simple ramp by using books for height and a plank of wood or piece of stiff cardboard. Models are tested by holding them at the top of the ramp and releasing them.

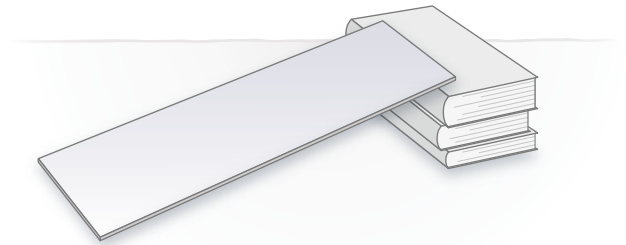

1. Build B1 (Sliding model).

Follow Building Instructions B, pages 4 to 6, steps 1 to 5.

2. Try out the model and make observations.

Find friction. Mark with an arrow where you think there is friction when you let the model slide down the ramp.

Students should be made aware that there is a lot of friction when one surface slides over another.

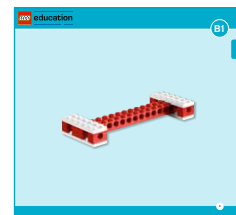

Measure how far the model travels.

Just how far the sliding model B1 will move will vary, depending on such variables as the surface and angle of the test ramp, and any effort used to push the model. Students will notice that the model is difficult to move. There is a lot of friction, and the sliding model, B1, won't travel far beyond the bottom of the ramp, if it slides down the ramp at all.

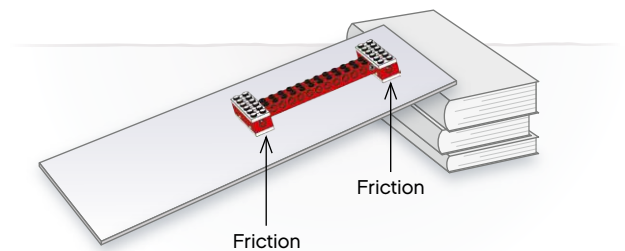

1. Build B2 (Rolling model).

Follow Building Instructions B, page 8, step 1.

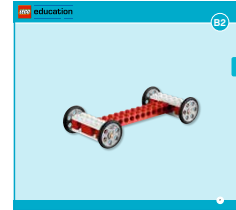
**2. Try out the model and make observations.**

Friction is a force that slows down motion when two surfaces move against each other.

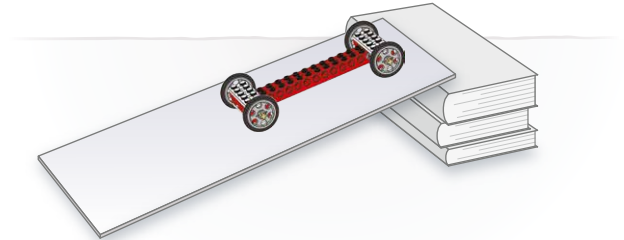

Is this model affected by friction?

Students might reasonably mark either answer! There is no significant friction between the tires and the surface of the ramp. New sections of the tire come into contact with the ramp surface as the wheel turns. On the other hand, there is friction in the axles where they are in contact with the surface of the holes through which they pass, and this does slow down the model.

Measure how far the model travels.

Students will notice that the effects of friction have been greatly reduced by the use of wheels. Students will not have to push the rolling model B2 very hard for it to move in the direction the wheels are facing, even on a flat surface; it will roll down the ramp easily when released, and the rolling model B2 travels further than the sliding model B1.

3. Compare model B1 to model B2.

How easy or difficult was it to make model B1 to move compared to model B2? Mark each model.

Students will notice that the rolling model B2 is much easier to move. The friction is greatly reduced by the wheels and axles, and the rolling model B2 will travel further than the sliding model B1.

1. Build B3 (Single, fixed axle model).

Follow Building Instructions B, pages 10 to 14, steps 1 to 9.

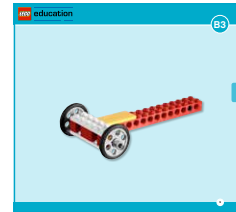

This model must be tested on a flat surface.

2. Try out the model and make observations.

Mark which type of axle is used in the model.



Model B3 is built with a single, fixed axle.

Test your model moving in a straight line.

Mark how easy or difficult it is to steer your model in a straight line.

Students will notice that model B3, with its single axle, is very easy to steer in a straight line.



Test your model turning a corner.

Mark how easy or difficult it is to steer your model round a corner.

Answers will vary depending on many variables such as the surface of the test track and the effort used to move the model. Students should notice, though, that model B3, with its single axle, is hard to steer through a sharp turn. When turning a corner sharply, one wheel will always skid. The wheels cannot turn at different speeds.

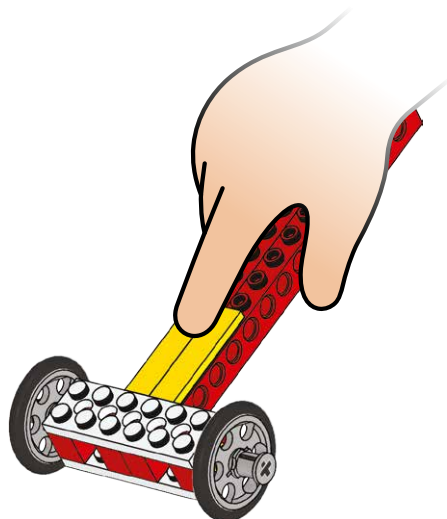

1. Build B4 (Separate axles model).

Follow Building Instructions B, pages 16 to 20, steps 1 to 7.

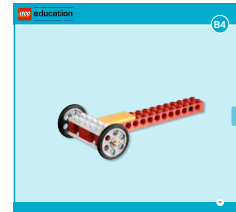

This model must be tested on a flat surface.

2. Try out the model and make observations.

Mark which type of axle is used in the model.



Model B4 is built with separate axles.

Test your model moving in a straight line.

Mark how easy or difficult it is to steer your model in a straight line.

Students will notice that model B4, with its separate axles, is very easy to steer in a straight line.



Test your model turning a corner.

Mark how easy or difficult it is to steer your model round a corner.

Students will notice that the model B4, with separate axles, is very easy to steer both in a straight line and when following zigzag patterns involving sharp turns. The separate axles allow the wheels to turn at different speeds.



3. Compare model B3 to model B4.

How easy or difficult was B3 to steer compared to B4?

Students will notice that model B4, with its separate axles, is easier to steer round corners than model B3, with its single axle.

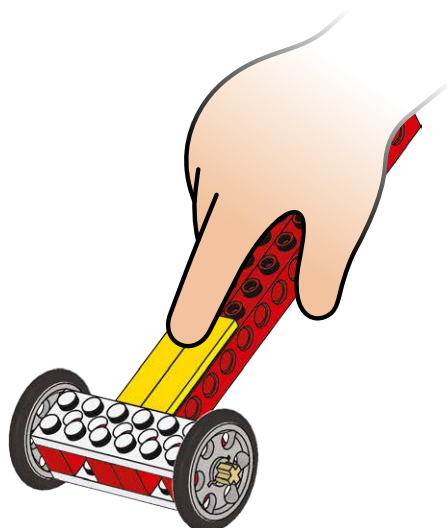

Name(s): _____

Date and subject: _____

Principle Models: Wheels and Axles

Student Worksheet

Things to talk about:

- What do you know about this simple machine?
- Where do we use this simple machine?
- Why do we use this simple machine?

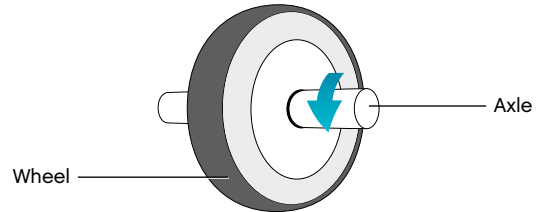

Build a ramp to test the first two principle models B1, B2.

Books for height and a plank of wood or piece of stiff cardboard should be effective. When your ramp is ready, then build and test the models, one at a time!

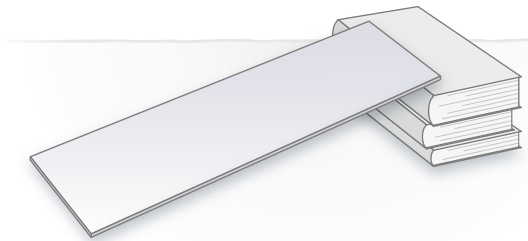

1. Build B1 (Sliding model).

Follow Building Instructions B, pages 4 to 6, steps 1 to 5.



2. Try out the model and make observations.

Find friction. Mark with an arrow where you think there is friction when you let the model slide down the ramp.



Measure how far the model travels. Write your answer here:



.....

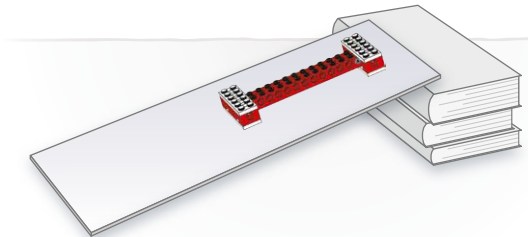

1. Build B2 (Rolling model).

Follow Building Instructions B page 8, step 1.



2. Try out the model and make observations.

Friction is a force that slows down motion when two surfaces move against each other.

Is this model affected by friction? YES / NO



YES	
-----	--

NO	
----	--

Measure how far the model travels. Write your answer here:



.....

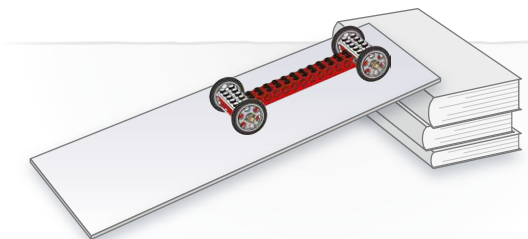

3. Compare model B1 to model B2.

How easy or difficult was it to make model B1 move compared to model B2?
Mark each model.



	Easy	Difficult

1. Build B3 (Single, fixed axle model).

Follow Building Instructions B, pages 10 to 14, steps 1 to 9.

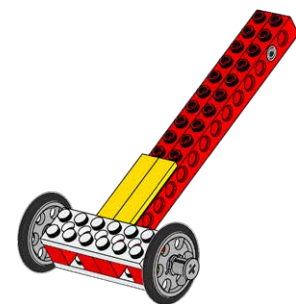

This model must be tested on a flat surface.

2. Try out the model and make observations.

Mark which type of axle is used in the model.

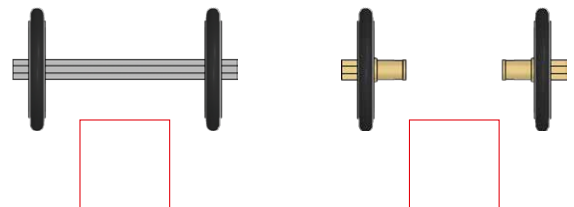

Test your model moving in a straight line.
Mark how easy or difficult it is to steer your model in a straight line.



	Easy	Difficult

Test your model turning a corner.
Mark how easy or difficult it is to steer your model round a corner.



	Easy	Difficult

1. **Build B4** (Separate axles model).
Follow Building Instructions B, pages 16 to 20, steps 1 to 7.

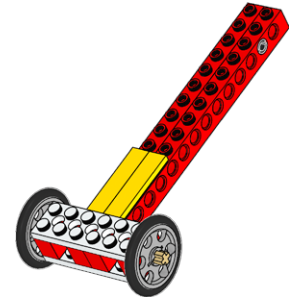

This model must be tested on a flat surface.

2. **Try out the model and make observations.**
Mark which type of axle is used in the model.

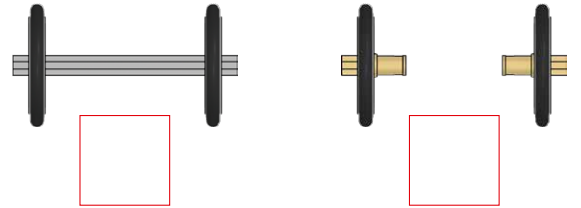

Test your model moving in a straight line.
Mark how easy or difficult it is to steer your model in a straight line.



	Easy	Difficult

Test your model turning a corner.
Mark how easy or difficult it is to steer your model round a corner.



	Easy	Difficult

3. **Compare model B3 to model B4.**
How easy or difficult was B3 to steer compared to B4?
Mark your answer.



	Easy	Difficult
<p>B3 Single, fixed axle</p>		
<p>B4 Separate axles</p>		

Main Activity: Go-Cart

Teacher's Notes

Learning Objectives

In this activity students will build and test models that use the following structures:

- A single, fixed axle
- Separate axles

To perform this activity, students should be familiar with the following vocabulary associated with wheels and axles:

- Friction
- Separate axles
- Single, fixed axle
- To skid
- To steer

If students have already worked with the principle models, they will already have observed wheels and axles, and the terms used in this activity should be familiar to them. Predictions should now be easier to make based on the observations made earlier. If the students have not worked on the principle models, then additional time will be needed, for example to introduce and explain the technical vocabulary used. If additional guidance is required, please turn to the "Overview: Wheels and Axles" or "Principle Models" sections.

Materials Required

- 9689 LEGO® Education Simple Machines Set

Other Materials Required

- A flat surface or test track where the models can drive in a straight direction, turn corners, and drive in a zigzag pattern.

◀ 9689



Connect



Hint

Most of the images used in the material can be found in the section "Images for Classroom Use", and are easy to display in class.

Sam and Sally love going to the fair. They enjoy racing on the go-cart track. It's also fun just to drive around, waving to their friends and families, but they have to keep a careful eye on the track—not all go-carts are that easy to steer.

Have you tried steering a go-cart?
What do you enjoy most about go-carts?
Which simple machine is needed for a go-cart to move and turn?

Let's build a go-cart!

Construct

1. First, build Go-Cart Model B5 and steer it around.

Follow Building Instructions B, pages 22 to 30, steps 1 to 13.

When Go-Cart Model B5 has been built, check the following:

- *If necessary, students should be made aware of how friction (see "Glossary" section) can affect movement. If the wheels are pushed in too far toward the body of the model they cannot turn freely.*
- *Make sure Sam or Sally is attached securely.*

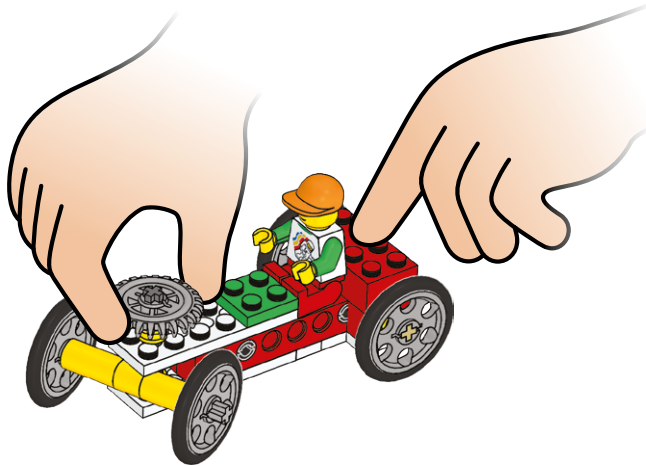

Hint

When testing the go-cart, use both hands to keep all four wheels on the track. Place one hand on the back of the cart and the other on the steering wheel.

Contemplate

2. Mark which type of axle is used for the front set of wheels.



Model B5 uses a single, fixed axle.

3. Then look carefully at the pictures of the models and compare Go-Cart Model B5 to Go-Cart Model B6.

- Circle what is different.
- What do you notice? Explain how the models are different.

Students should notice the difference in the axles used for the front set of wheels. Model B5 uses a single axle, while model B6 uses separate axles.

4. Next, look carefully at the pictures of the models and make a prediction.

If I compare model B5 to model B6, then I think that Go-Cart Model (B5/B6) will be the easier to steer.

Encourage students to discuss the effects the different axles will have on the go-carts in their own words. For the prediction, the correct answer is model B6; however, it does not matter whether students get the answer right or wrong at this point, only that they should make a prediction that can be checked later.

5. Test Go-Cart Model B5.

Students observe and test the degree of ease with which they can steer the model in a straight line and around a sharp corner. Encourage them to try more than once to ensure that their observations are correct.

The students will notice that Go-Cart Model B5 is very easy to steer when driving in a straight line. However, they will also notice that it is hard to steer through sharp turns or in a zigzag pattern, as the wheels cannot turn at different speeds. One wheel will always skid when turning corners. Students must write their answers in the chart.

Note: *If possible, keep an example of Go-Cart Model B5 for students to compare with Go-Cart Model B6.*

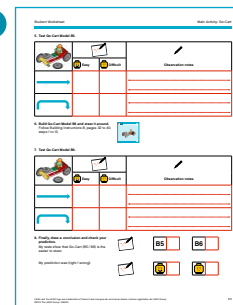
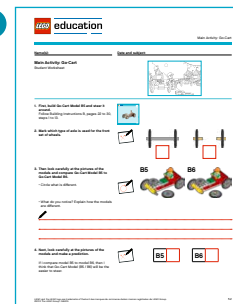

6. Build Go-Cart Model B6 and steer it around.

Follow Building Instructions B, pages 32 to 40, steps 1 to 13.

Encourage students to identify parts while they are trying out the model.

7. Test Go-Cart Model B6.

Students observe and test the degree of ease with which they can steer the model in a straight line and around a sharp corner. Encourage them to try more than once to ensure that their observations are correct.

The students will notice that Go-Cart Model B6 is very easy to steer, both when driving in a straight line and when following zigzag patterns involving sharp turns. The separate axles allow the wheels to turn at different speeds. Students must write their answers in the chart.

8. Finally, draw a conclusion and check your prediction.

Go-Cart Model B6 turns more easily because of the use of separate axles.



 A student worksheet titled "Go-Cart Model B6" with a "Name: _____" field. It contains two identical testing sections. Each section includes:

- A small diagram of the Go-Cart Model B6.
- A table with columns for "Time", "Observations", and "Conclusion".
- Section 1: "1. Test Go-Cart Model B6 and steer it around a sharp corner." with a "1 min" timer icon.
- Section 2: "2. Test Go-Cart Model B6 and steer it in a straight line." with a "1 min" timer icon.
- Section 3: "3. Draw a conclusion about the use of separate axles." with checkboxes for "B6" and "B6".
- Section 4: "4. Write a conclusion about the use of separate axles." with checkboxes for "B6" and "B6".

Continue

Students are asked to build a test track and to explore the movements of the go-carts. Student are also encouraged to rebuild the go-cart by, for example, exploring the effect of using separate axles for the back set of wheels, or by using different wheels. They must write down their observations.

Note: There are no building instructions included to guide students through the Continue phase.

Encourage students to discuss the effects the different wheels and axles will have on the go-carts in their own words, prompting them with questions such as:

- Describe what happened when you tried steering the go-cart.
- How easy/difficult was it to steer around the test track? Why do you think that was?
- Describe how the model works.
- What did you do to make sure your observations were correct?

It is suggested that students should draw different items where they find wheels and axles used in everyday machines and mechanisms. For inspiration, read or show the "Overview: Wheels and Axles" section.

Optional

With more advanced students, you might consider introducing wheels as rollers or exploring the wheel and axle as a winch. Wheels do not have to roll on the ground to be effective; roller conveyors use wheels to move objects easily. In a winch, the wheel is the circular path traced in the air by the crank handle.

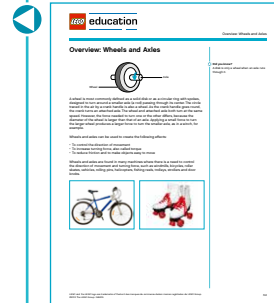
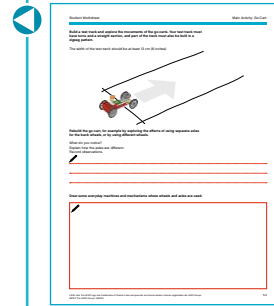

Go-Cart

Class: _____

Date: _____

Performance and Learning Targets Linked to the Activity and the Eight Next Generation Science Practices Observe the suggested student behaviors while working with the activity. Either use the suggested Emerging (E), Developing (D), Proficient (P), Accomplished (A) proficiency level descriptions or use one relevant to your context.	Name(s)												
Student Performance Targets Linked to the Activity To what degree can the student...?													
Adequately build the Go-Cart model(s) with help or independently using the Building Instruction (1, 2, 3, 6)													
Use the model to demonstrate and share understanding of science terms and make predictions about the use of wheels and axles (E.g. Fixed axles, Separate axles) (1, 3, 4, 5, 8)													
Use prior knowledge of cars to describe orally or in writing scientific problems that can be solved using wheels and axles (1, 6, 8)													
Make changes or create a new model design in order to create a more advanced model based on tests and data (2, 3, 4, 6)													
Use Go-Cart worksheets to record and analyze data collected from the model investigation (3, 4, 5)													
Selected Student Learning Targets Linked to the Practices To what degree can the student...?													
Ask questions and make observations about what would happen if a variable is changed (1, 3)													
Demonstrate ability to use fair testing of models and make adjustments based upon test data and measurements (3, 4, 6)													
Test different model designs of the same object to determine which one better meets the criteria (3)													
Estimate, collect, measure, describe and/or graph quantities to make comparisons across teams and listen to the ideas of others (4, 5, 6, 7, 8)													
Communicate the meaning of the findings with others (E.g. orally, in drawing or writing) (4, 8)													
Optional Student Learning Targets													
Lesson Observational Notes:													

Name(s): _____

Date and subject: _____

Main Activity: Go-Cart

Student Worksheet

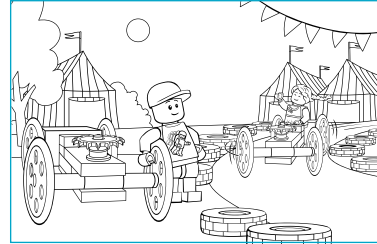

1. First, build Go-Cart Model B5 and steer it around.
Follow Building Instructions B, pages 22 to 30, steps 1 to 13.



2. Mark which type of axle is used for the front set of wheels.

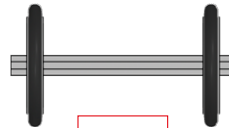

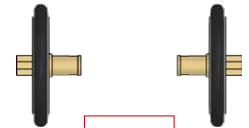

3. Then look carefully at the pictures of the models and compare Go-Cart Model B5 to Go-Cart Model B6.

- Circle what is different.

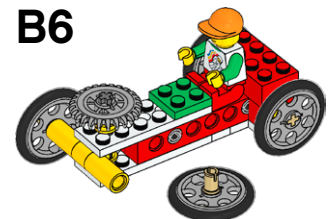
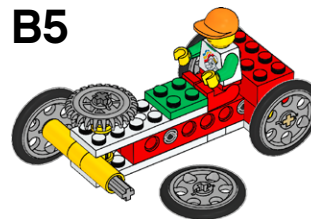

- What do you notice? Explain how the models are different.



.....

.....

.....

4. Next, look carefully at the pictures of the models and make a prediction.







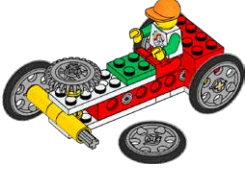

B5	
-----------	--

B6	
-----------	--

If I compare model B5 to model B6, then I think that Go-Cart Model (B5 / B6) will be the easiest to steer.







5. Test Go-Cart Model B5.

			 Observation notes
	 Easy	 Difficult	
		
		

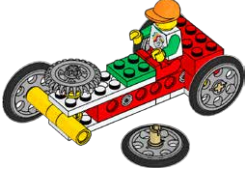
6. Build Go-Cart Model B6 and steer it around.
 Follow Building Instructions B, pages 32 to 40, steps 1 to 13.



7. Test Go-Cart Model B6.

			 Observation notes
	 Easy	 Difficult	
		
		

8. Finally, draw a conclusion and check your prediction.
 My tests show that Go-Cart (B5 / B6) is easier to steer.



B5	
-----------	--

B6	
-----------	--

My prediction was (right / wrong).



	
--	--

	
---	--

Build a test track and explore the movements of the go-carts. Your test track must have turns and a straight section, and part of the track must also be built in a zigzag pattern.

The width of the test track should be at least 13 cm (6 inches).

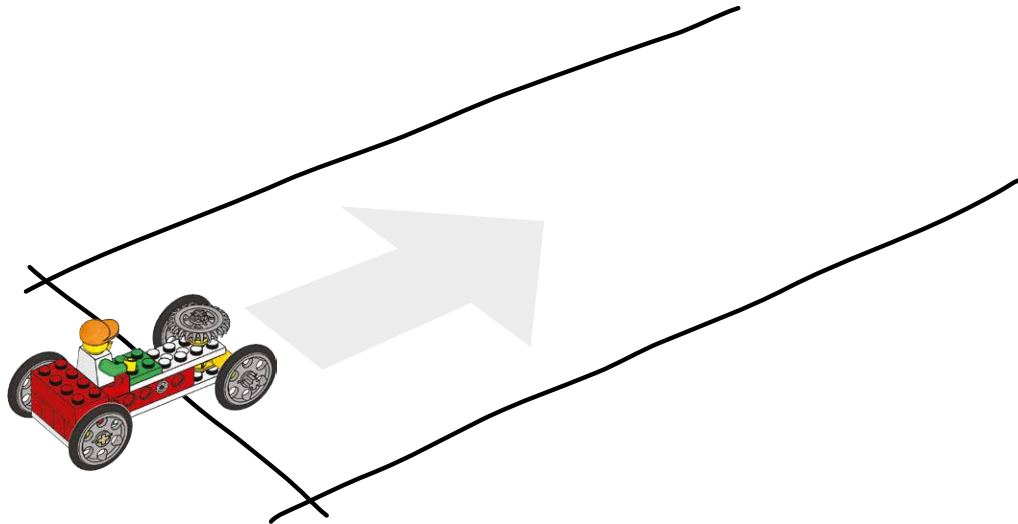

Rebuild the go-cart, for example by exploring the effects of using separate axles for the back wheels, or by using different wheels.

What do you notice?
Explain how the axles are different.
Record observations.



.....

.....

.....

Draw some everyday machines and mechanisms where wheels and axles are used.



[Large empty rectangular box for drawing]

Activity Name: _____

Student Name: _____

Date: _____

How did you do?

Directions: Circle the brick that shows how well you did. The bigger brick, the better you did.

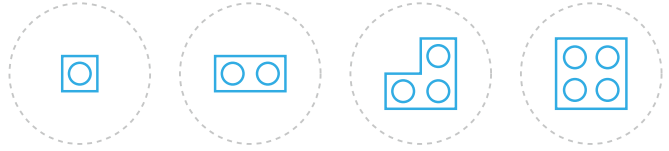
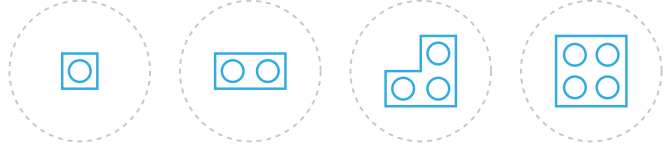
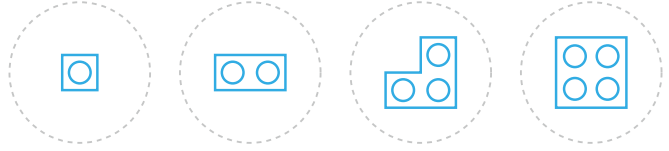
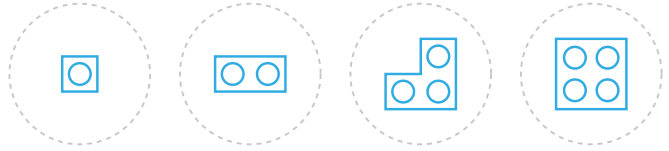
<p>I asked questions to understand what to do. I understood what to do.</p>	
<p>I made predictions and tested my model. I made observations and gathered data.</p>	
<p>I shared my ideas. I listened to my team.</p>	
<p>I used scientific words. I used fair testing.</p>	

Describe what you did (Draw, write or add a photo):

Tell someone what you learned...

Problem-Solving Activity: Wheelbarrow

Student Worksheet



When Sam and Sally visit the fair they always remark on how tidy the area is kept. However, not everybody remembers to throw their litter in the bin! Having so many people in one place at one time means that a lot of people working at the fair have to spend time picking up litter. Sam and Sally want to help the people working at the fair to carry the many the bags of litter that have been gathered.

Let's help Sam and Sally!

Build a wheelbarrow like the one in the picture.

Your design brief is as follows:

- Build a wheelbarrow.
- Give your wheelbarrow handles, and legs to support it while standing.
- Your wheelbarrow must be able to carry the LEGO® weight.

When you have finished, test the wheelbarrow. Push it along with the LEGO weight in it, and check to see if it is well balanced. Assess how easily the wheelbarrow can be moved in a straight direction and turned. What makes it easy or difficult to steer?

Need help?

Look at:

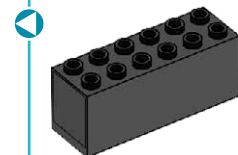
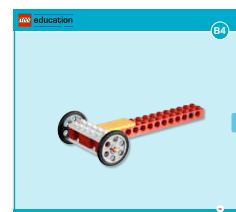
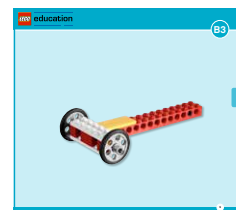
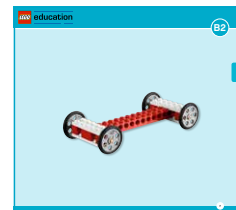
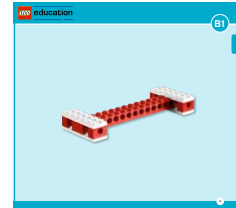

Activity Name: _____

Student Name: _____

Date: _____

How did you do?

Directions: Circle the brick that shows how well you did. The bigger brick, the better you did.

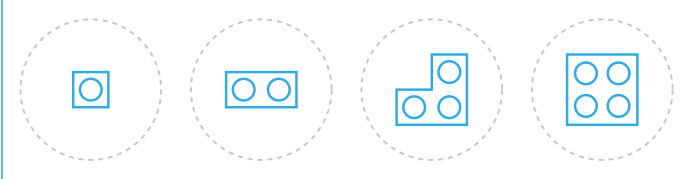
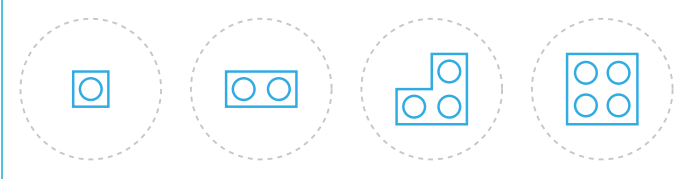
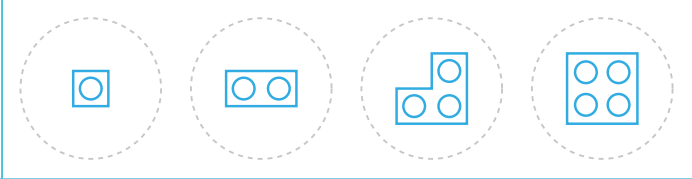
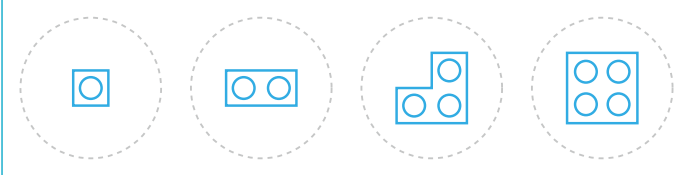
<p>I read the design brief. I understood the problem.</p>	
<p>I built a model to solve the problem. I tested the model and made improvements.</p>	
<p>I shared my ideas. I listened to my team.</p>	
<p>I used scientific words. I can do engineering and design.</p>	

Describe what you did (Draw, write or add a photo):

Tell someone about the problem you solved...

Problem-Solving Activity: Wheelbarrow

Teacher's Notes

Learning objectives:

Students are encouraged do some research related to the real-life problem they are set to solve and/or the type of simple machine that they are going to use, and to:

- Identify a need or a problem
- Develop explanations using observations
- Test, evaluate, and redesign models

Introduction

To help in the design process, instruct the students to look at the picture on the student worksheet and read the accompanying text. If time and facilities are available, have your students conduct research, and also encourage them to generate ideas and questions by posing problems they must take into account in their design and building process. Your students could search the Internet to learn more about the appearance, structure, and function of different sorts of litter carts and wheelbarrows.

Students should be reminded of the principle models that they have worked with. It might be a good idea to build principle models B3 and B4 to show the different structures.

Discuss the design problem specified in the design brief in class. Try to find several possible general solutions, or use the suggested solution for inspiration if necessary.

Discuss the constraints and functions your students will have to take into account to carry out the design brief. Try to get your students to focus on relevant issues and decisions by asking questions. These might include:

- How will your model look?
Maybe a handcart with wheels, and perhaps handles for pushing it and a space for the load. Or maybe simply a wheelbarrow like the one shown in the drawing.
- What LEGO® elements do you have available? Should you use big wheels or small wheels for the wheelbarrow, and how will your wheelbarrow stand on the ground? What can you use as legs to support the wheelbarrow?
- How do you think you might start building?

Optional Materials

Materials for enhancing the appearance and functionality of the model: Students can use paper, cardboard, and markers to make the bin element of the wheelbarrow or to make bags of litter. Additional LEGO elements, if available, may be used.

When the model is finished, encourage students to reflect on both the product that they have produced and the processes they have used by:

- Carrying out tests to evaluate the performance of their model
- Reflecting on the design brief
- Recording their design by drawing or taking digital photos

Hint

Most of the images used in the material can be found in the section “Images for Classroom Use”, and are easy to display in class.

Need help?

Look at:

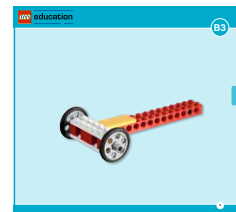

Did you know?

The LEGO weight element weighs approximately 53 g (1.8 oz.).



Suggested Model Solution

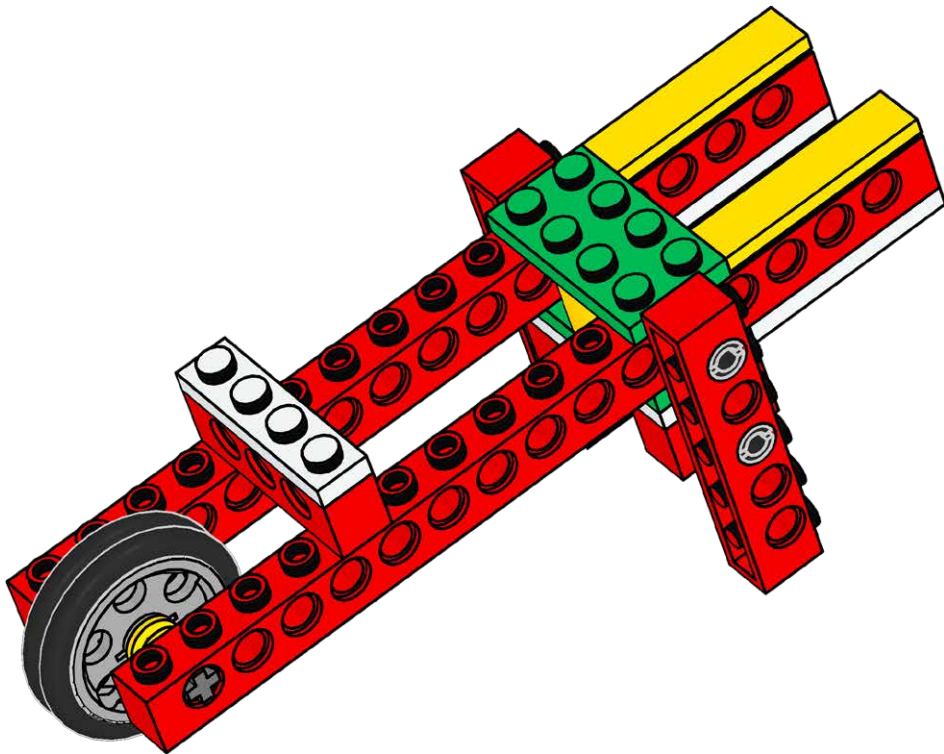

Wheelbarrow

Class: _____

Date: _____

Performance and Learning Targets Linked to the Activity and the Eight Next Generation Science Practices Observe the suggested student behaviors while working with the activity. Either use the suggested Emerging (E), Developing (D), Proficient (P), Accomplished (A) proficiency level descriptions or use one relevant to your context.	Name(s)											
Student Performance Targets Linked to the Activity To what degree can the student...?												
Plan, develop a design, and build a wheelbarrow that meets or exceeds the Design Brief criteria based upon research (E.g. Has handles, Has legs, Is able to carry the LEGO® weight) (1, 2, 8)												
Design and compare multiple solutions to solve the problem and demonstrate understanding of cause and effect as well as structure and function of design system (2, 6)												
Record findings with drawings or digitally to share design ideas with others (2, 5, 7, 8)												
Evaluate and make changes to the model based upon observations and data using fair testing (1, 3, 4, 5, 8)												
Compare models to determine the best solution to the problem (6, 7)												
Selected Student Learning Targets Linked to the Practices To what degree can the student...?												
Ask questions and make observations about what would happen if a variable is changed (1, 3)												
Apply scientific ideas to solve design problems (6)												
Estimate, collect, measure, describe and/or graph quantities to make comparisons across teams and listen to the ideas of others (4, 5, 6, 7, 8)												
Communicate the meaning of the findings with others (E.g. orally, in drawing or writing) (4, 8)												
Discuss evidence that shows how the solution meets the criteria and constraints of the problem (7)												
Optional Student Learning Targets												
Lesson Observational Notes:												

Overview: Levers

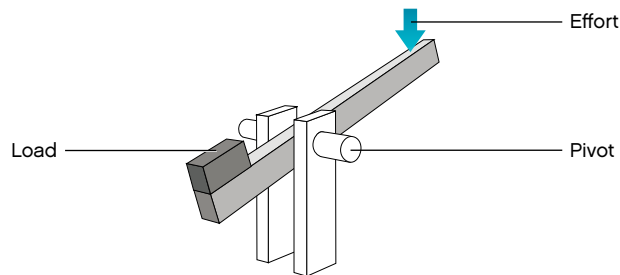

A lever is most commonly defined as a rod or arm that tilts around a pivot, also called a fulcrum, to produce useful motion. The load is moved by the effort (a push or pull) used to make the lever tilt about the pivot. With a lever arm or lever beam, a load can be lifted with the least effort by placing it as close to the pivot as possible, or by applying the effort as far from the pivot as possible.

There are three main arrangements of the pivot, load, and effort, creating three types or classes of levers. A first class lever has the pivot between the effort and load, and is used to do work and to produce useful movement. A second class lever has the load between the effort and pivot, and is used mainly to do work. A third class lever has the effort between the pivot and load, and is used mainly to amplify movement.

Levers can be used to create the following effects:

- To apply a force at a distance
- To change the direction of a force
- To increase force
- To increase movement

Levers are found in many machines, such as wheelbarrows, oars, rakes, nutcrackers, tweezers, screwdrivers, snow shovels, hammers, bottle openers, light switches, staplers, crowbars, scissors, and seesaws.



Did you know?

Levers make work easier by amplifying motion or force, or by changing the direction of a force.

Establishing the Concept

We recommend establishing the concept of the simple machine to be worked on. This could be done, for example, by showing students a number of exhibits from the LEGO® set to stimulate their interest. Build a principle model, or show some of the images from Images for Classroom Use, asking questions such as “What do you know about this simple machine?” or “Where do we use this simple machine?” See if students can name any of the objects you show them, and allow time for students to handle them.

Providing the Vocabulary

Students will acquire the necessary vocabulary for the simple machine as they progress through the activities, but it may be useful to introduce certain terms at this stage. Important new vocabulary items are *effort*, *load*, *pivot*, and *lever beam*.

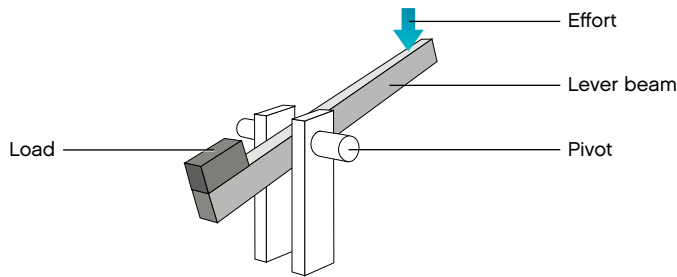

Understanding the Principles

The principle models are designed to help students understand the principles of the simple machine in focus through hands-on experience before they move on to construct the main models.

The principle models are presented in a logical sequence that will build on students' understanding. The principle models can only be built one at a time from the parts in the set.

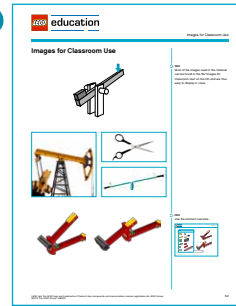
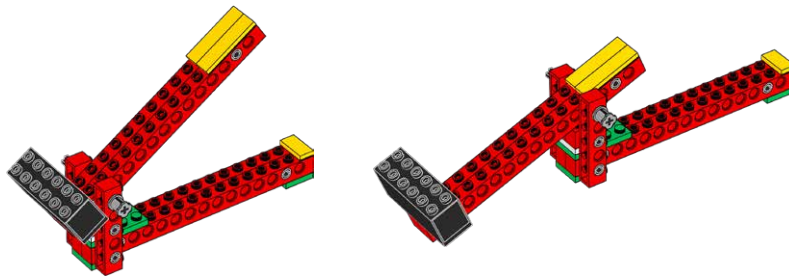

Using the Principle Models

1. The yellow elements indicate where to hold, push, lift, or apply force/effort in handling the principle models. The principle models need to be held correctly if they are to work properly.

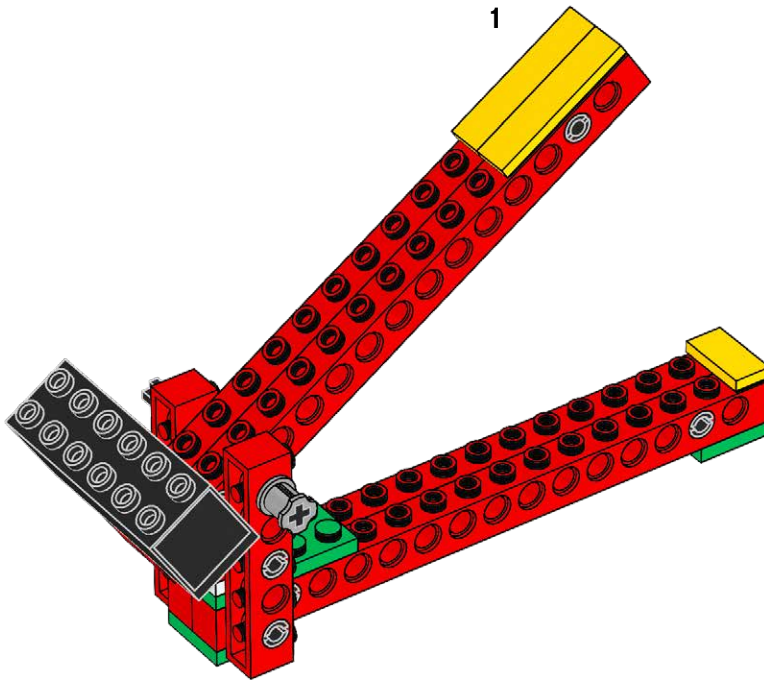

First Class Lever

A first class lever has the pivot placed between the effort and the load. This type of lever changes the direction of the effort force and can change the amount of effort needed to lift or move a load. A seesaw is an example of a first class lever.

Hint

It is possible to introduce second and third class levers simply by rebuilding the model. See next page.

Second Class Lever

A second class lever has the load placed between the effort and the pivot. This type of lever does not change the direction of the effort force, but can reduce the amount of effort needed to lift a load. A wheelbarrow is an example of a second class lever.

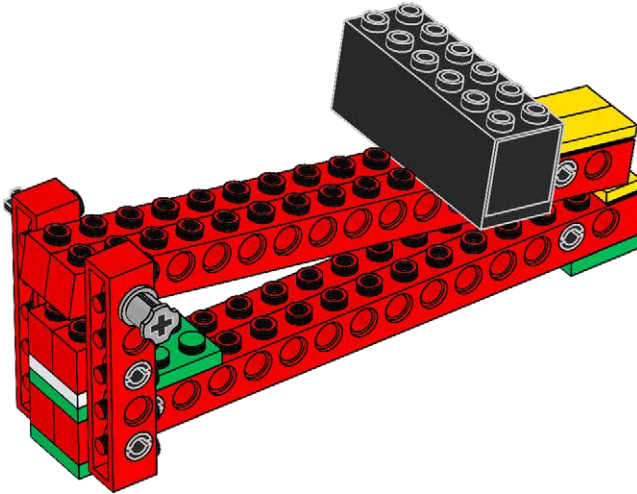

Did you know?

Levers can be connected together through a common pivot to produce useful tools and mechanisms; scissors, nutcrackers, and tweezers are all connected levers.

Third Class Lever

A third class lever has the effort between the load and the pivot. This type of lever does not change the direction of the effort force, but can increase the distance the effort moves a load. A broom is an example of a third class lever.

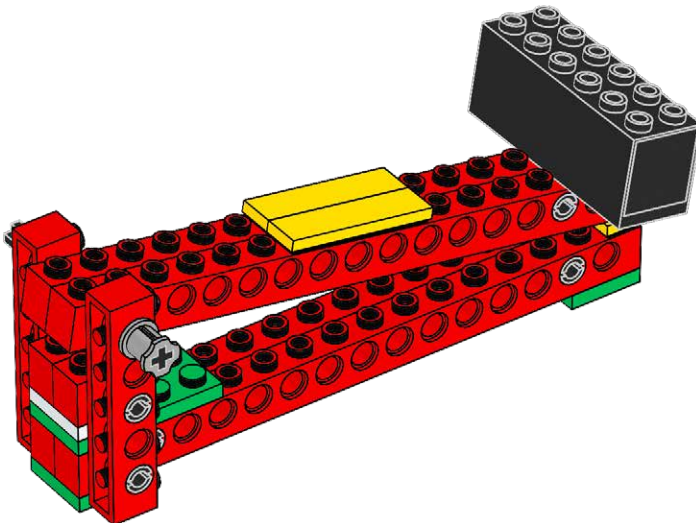

Images for Classroom Use

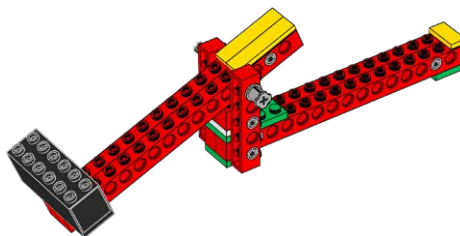
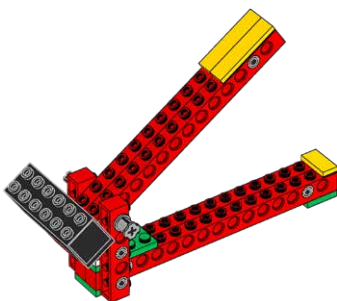
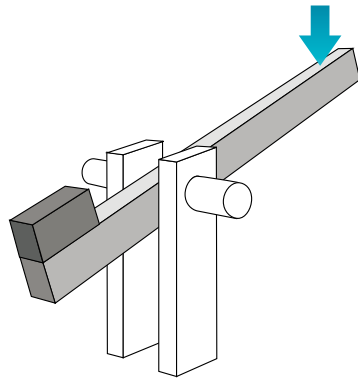

Hint

Most of the images used in the material can be found in the section “Images for Classroom Use”, and are easy to display in class.

Hint

Use the element overview.

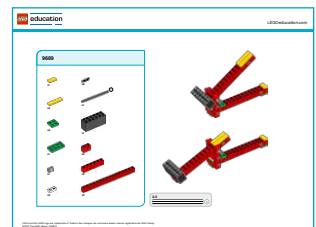

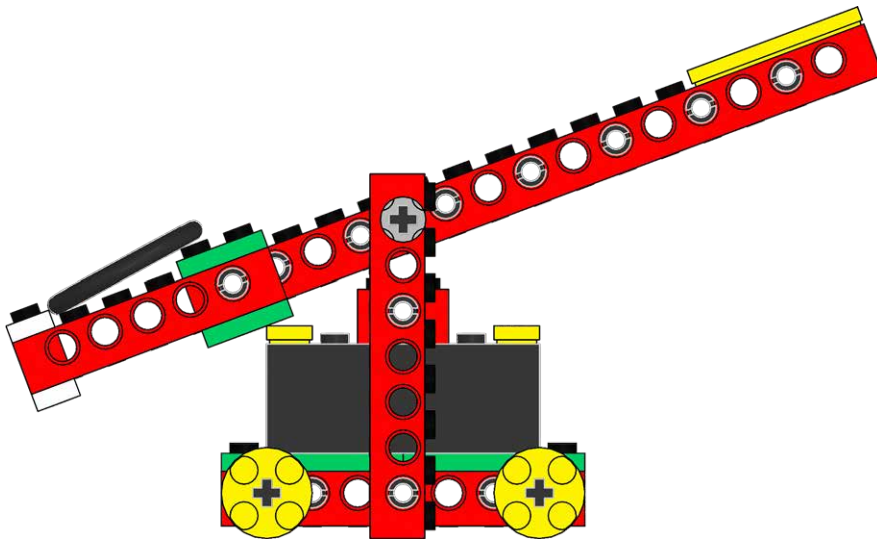

Hint

It is often more practical to sort out the elements that will be needed before starting work on the models.

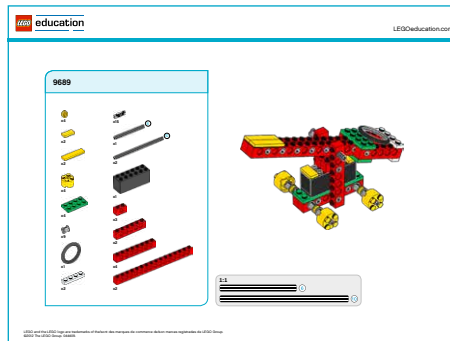
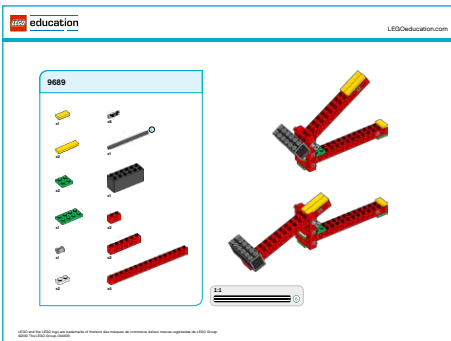

Hint

The element overview can be printed and used as a checklist for students to use when they are taking out and putting away their elements.

Principle Models: Levers

Teacher's Notes

Things to talk about:

- What do you know about this simple machine?
- Where do we use this simple machine?
- Why do we use this simple machine?

Relate students' answers to some of the images from "Images for Classroom Use" or find ideas from the "Overview: Levers" section to stimulate students' interest.

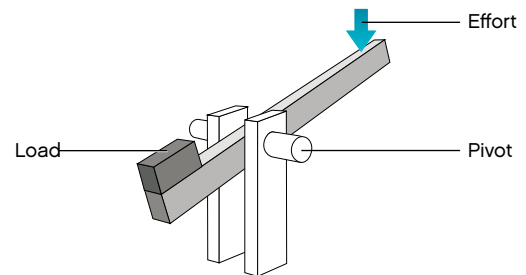

1. Build C1 (First class lever C1).

Follow Building Instructions C, pages 4 to 12, steps 1 to 10.

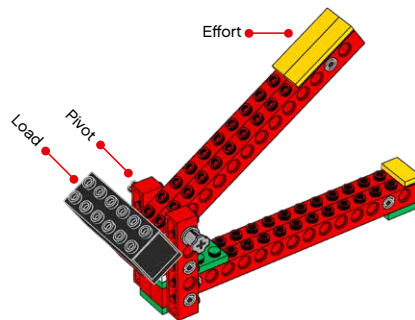

2. Label the lever.

Draw lines from the words to the picture of the model.

First class levers have the pivot positioned between the effort and the load.

3. Classify an item.

Which real life item is a first class lever?

A crowbar is a first class lever.



a) Crowbar

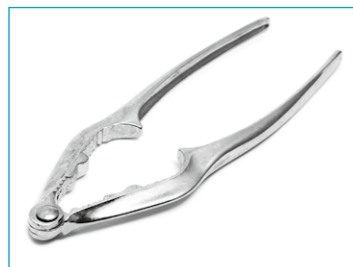

b) Nutcracker



c) Tweezers

4. Try out the model and make observations.

Try out lever C1. Assess and make a note about the amount of effort needed to move the load.

1. Build C2 (First class lever C2).

Follow Building Instructions C, page 14, step 1.



2. Try out the model and make observations.

Try out lever C2. Assess and make a note about the amount of effort needed to move the load. Observe how the difference in length from the pivot to the load affects the amount of effort needed to move the load.

After testing both levers, compare your observations and explain, either by writing your answer or by drawing with different sized arrows, how much effort is needed with each lever.

Lever C1 needs the least amount of effort (the smallest arrow) to move the load, because it has the shortest distance from the pivot to the load compared to lever C2.

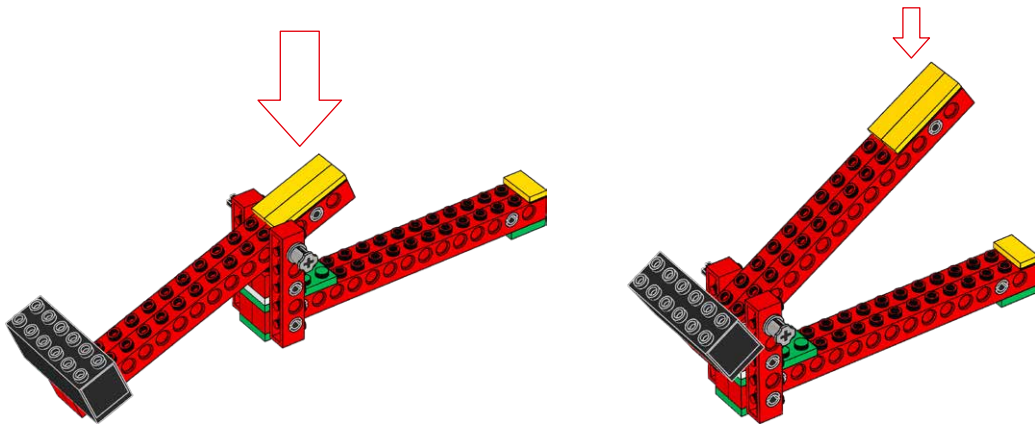



Name(s): _____

Date and subject: _____

Principle Models: Levers

Student Worksheet

Things to talk about:

- What do you know about this simple machine?
- Where do we use this simple machine?
- Why do we use this simple machine?

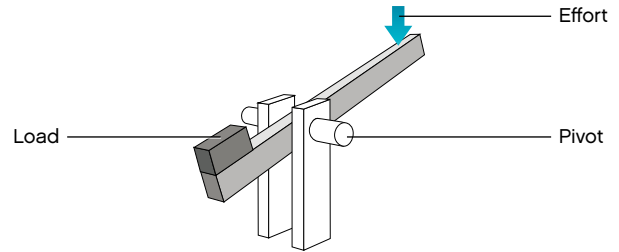

1. Build C1 (First class lever C1).

Follow Building Instructions C, pages 4 to 12, steps 1 to 10.



2. Label the lever.

Draw lines from the words to the picture of the model.



- Effort ●
- Pivot ●
- Load ●

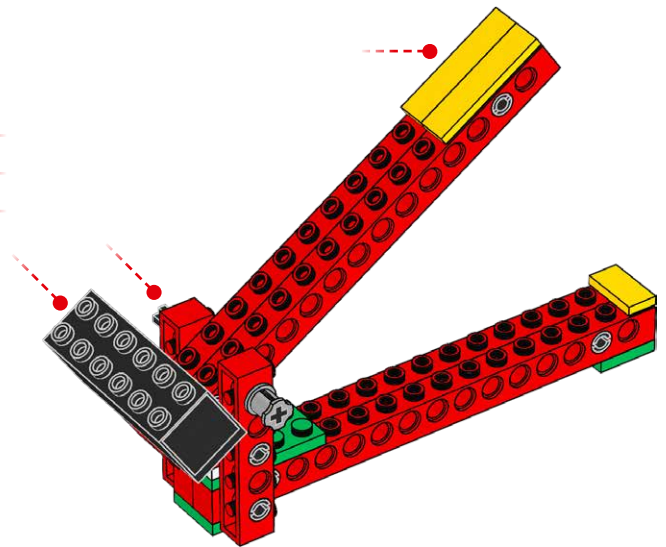

3. Classify an item.

Which real life item is a first class lever?
Circle the item or write your answer here:



.....



a) Crowbar



b) Nutcracker



c) Tweezers

4. Try out the model and make observations.

Try out lever C1. Assess and make a note about the amount of effort needed to move the load.



.....

.....

.....

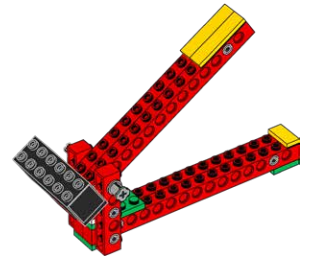

1. Build C2 (First class lever C2).

Follow Building Instructions C, page 14, step 1.



2. Try out the model and make observations.

Try out lever C2. Assess and make a note about the amount of effort needed to move the load. Observe how the difference in length from the pivot to the load affects the amount of effort needed to move the load.



.....

.....

.....

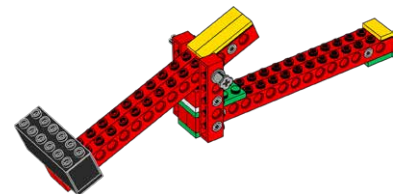

After testing both levers, compare your observations and explain, either by writing your answer or by drawing with different sized arrows, how much effort is needed with each lever.



.....

.....

.....

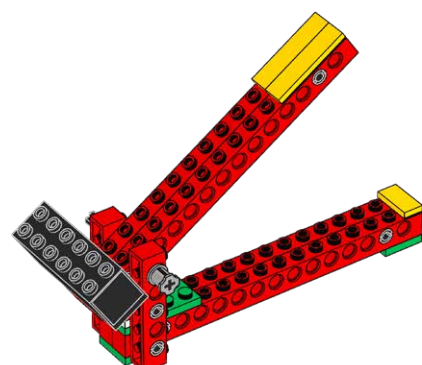
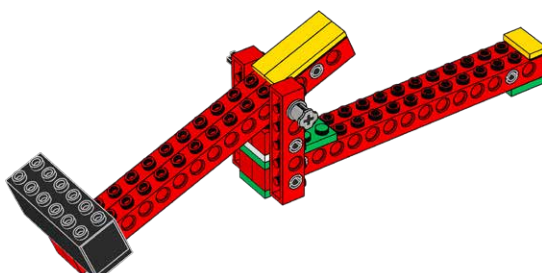



Main Activity: Catapult

Teacher's Notes

Learning Objectives

In this activity students will build and test models that use the following structures:

- First class levers

To perform this activity, students should be familiar with the following vocabulary associated with levers:

- Pivot
- Load
- Effort

If students have already worked with the principle models, they will already have observed levers, and the terms used in this activity should be familiar. Predictions should now be easier to make based on their observations made earlier.

If the students have not worked on the principle models, then additional time will be needed, for example to introduce and explain the technical vocabulary used.

If additional guidance is required, please turn to the "Overview: Levers" or "Principle Models" sections.

Materials Required

- 9689 LEGO® Education Simple Machines Set

◀ 9689



Connect



Hint

Most of the images used in the material can be found in the section "Images for Classroom Use", and are easy to display in class.

Sam and Sally love going to the fair. There is a catapult game, where players shoot at a goal to win prizes by scoring most points. Sam and Sally love competing against their friends and families!

Do you like playing games where you have to aim at a goal?
 What do you enjoy most about them?
 Which simple machine is needed for a catapult to work?

Let's build a catapult!

Construct

1. First, build Catapult Model C3 and try it out.

Follow Building Instructions C, pages 16 to 30, steps 1 to 16.

Note: Be careful not to let students point the catapult toward anybody's face when catapulting the rubber tire.

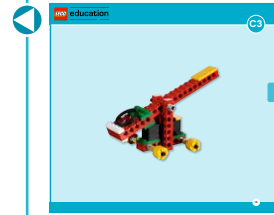
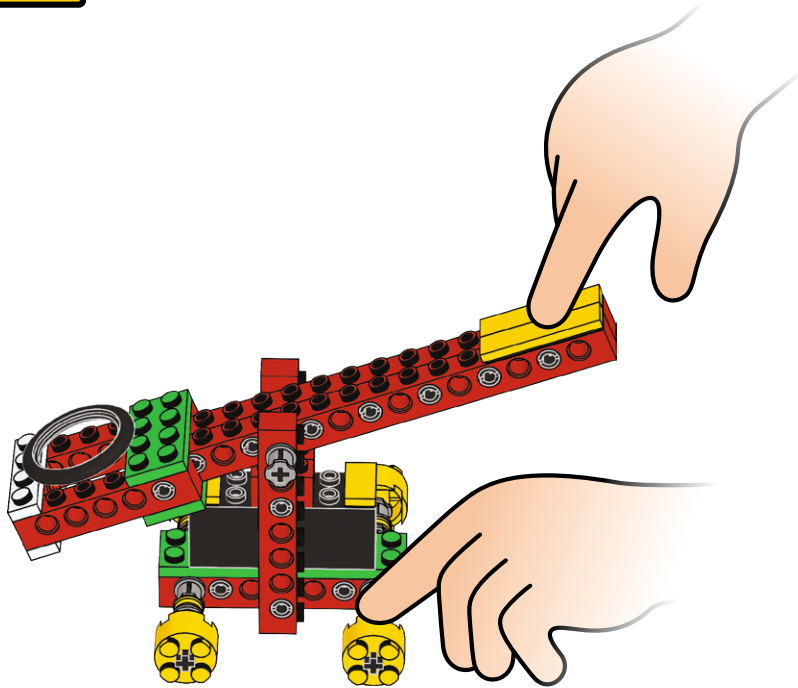

Hint

Place one hand on the side of the catapult when catapulting the rubber tire. To avoid any risk of students getting hit, make sure all the class know which direction the catapult is to be fired in.

Contemplate

2. Label the model; draw lines from the words to the model.

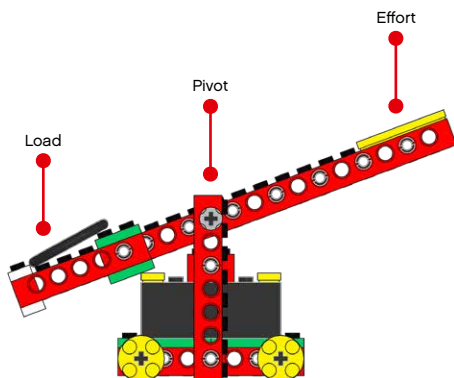

Which class of lever is the catapult?

The catapult is a first class lever, which has the pivot positioned between the effort and the load.

3. Then, look carefully at the pictures of the models and compare Catapult Model C3 to Catapult Model C4.

- Count how many LEGO® studs or holes there are on the lever beam from the pivot to the load in the two models.
- What do you notice? Explain how the two models are different.

Students should notice that even though both catapults are first class levers, the lengths from the load to the pivot differ in model C3 and model C4.

4. Next, look carefully at the pictures of the models and make a prediction.

If I compare model C3 to model C4, then I think Catapult Model (C3/C4) will throw the tire further.

Encourage students to discuss the effects the different lengths between the load and the pivot will have on the catapults in their own words. For the prediction, the correct answer is model C4; however, it does not matter whether students get the answer right or wrong at this point, only that they should make a prediction that can be checked later. Even though many variables will affect the catapult—especially the amount of effort used—model C4 should still throw further than C3, because the beam is longer from the load to the pivot in model C4.

5. Test Catapult Model C3.

Have students observe the starting place of the lever, including the lever beam, the pivot and the load on the catapult. Encourage them to try more than once, to ensure that their observations are correct. Students must write their measurements on the student worksheet.

Note: If possible, keep an example of Catapult Model C3 for students to compare with Catapult Model C4.

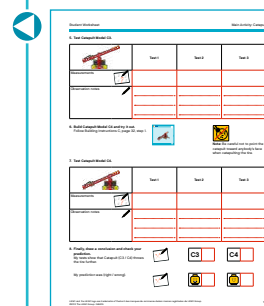
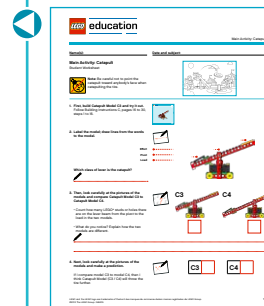

6. Build Catapult Model C4 and try it out.

Follow Building Instructions C, page 32, step 1.

Encourage students to identify parts while they are trying the model. Students should be asked to count how many LEGO® studs there are from the pivot to the load.

7. Test Catapult Model C4.

Encourage students to try more than once, to ensure that their observations are correct. Students must write their measurements on the student worksheet.

8. Finally, draw a conclusion and check your prediction.

Catapult Model C4 throws the furthest because of the distance between the pivot and the load.

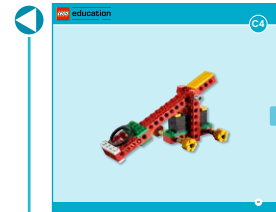

A student worksheet for the Catapult Model C4 activity. It contains two tables for recording data, each with columns for 'Trial 1', 'Trial 2', and 'Trial 3'. The tables are used for testing the catapult model. The worksheet also includes instructions and a small diagram of the catapult model.

	Trial 1	Trial 2	Trial 3
Distance from pivot to load (cm)			
Distance from pivot to launch point (cm)			
Distance from pivot to landing point (cm)			

	Trial 1	Trial 2	Trial 3
Distance from pivot to load (cm)			
Distance from pivot to launch point (cm)			
Distance from pivot to landing point (cm)			

Continue

Students are encouraged to make a game with rules that they can play using the catapult.

Note: *There are no building instructions included to guide students through the Continue phase, other than the illustrated suggestions on the student worksheet.*

Encourage your students to discuss the importance of agreeing on rules for the game before playing, prompting them with questions such as:

- What is the aim of the game?
- Describe what happens if you miss.
- How many times are you allowed to try?
- Describe how you can win the game.
- How will you make sure your rules are followed?

It is suggested that students create a sign explaining the rules and inviting people to play the game.

Optional

It is suggested that students should draw different items where they find levers used in everyday machines and mechanisms. For inspiration, read or show the “Overview: Levers” section.

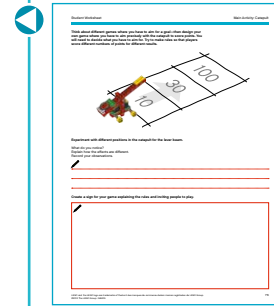

Hint

Most of the images used in the material can be found in the section “Images for Classroom Use”, and are easy to display in class.

Catapult

Class: _____

Date: _____

Performance and Learning Targets Linked to the Activity and the Eight Next Generation Science Practices Observe the suggested student behaviors while working with the activity. Either use the suggested Emerging (E), Developing (D), Proficient (P), Accomplished (A) proficiency level descriptions or use one relevant to your context.	Name(s)											
Student Performance Targets Linked to the Activity To what degree can the student...?												
Adequately build the Catapult model(s) with help or independently using the Building Instruction (1, 2, 3, 6)												
Use the model to demonstrate and share understanding of science terms and make predictions about the use of levers (E.g. Arm, Pivot, Effort, Load) (1, 3, 4, 5, 8)												
Use prior knowledge of seesaws to describe orally or in writing scientific problems that can be solved using levers (1, 6, 8)												
Make changes or create a new model design in order to create a more advanced model based on tests and data (2, 3, 4, 6)												
Use Catapult worksheets to record and analyze data collected from the model investigation (3, 4, 5)												
Selected Student Learning Targets Linked to the Practices To what degree can the student...?												
Ask questions and make observations about what would happen if a variable is changed (1, 3)												
Demonstrate ability to use fair testing of models and make adjustments based upon test data and measurements (3, 4, 6)												
Test different model designs of the same object to determine which one better meets the criteria (3)												
Estimate, collect, measure, describe and/or graph quantities to make comparisons across teams and listen to the ideas of others (4, 5, 6, 7, 8)												
Communicate the meaning of the findings with others (E.g. orally, in drawing or writing) (4, 8)												
Optional Student Learning Targets												
Lesson Observational Notes:												

Name(s): _____

Date and subject: _____

Main Activity: Catapult

Student Worksheet



Note: Be careful not to point the catapult toward anybody's face when catapulting the tire.

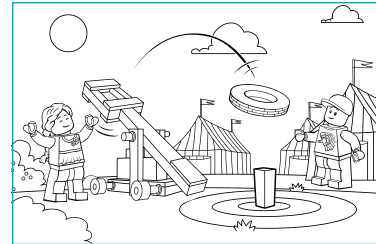

1. First, build Catapult Model C3 and try it out.
Follow Building Instructions C, pages 16 to 30, steps 1 to 16.

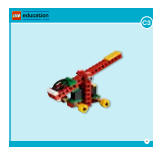

2. Label the model; draw lines from the words to the model.



Effort ●
Pivot ●
Load ●

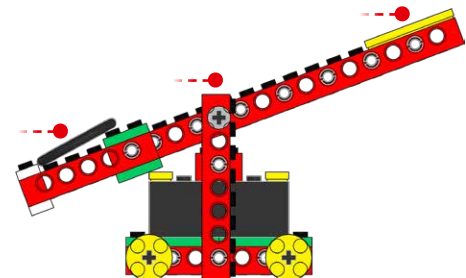

Which class of lever is the catapult?



.....

3. Then, look carefully at the pictures of the models and compare Catapult Model C3 to Catapult Model C4.



- Count how many LEGO® studs or holes there are on the lever beam from the pivot to the load in the two models.
- What do you notice? Explain how the two models are different.



.....

.....

4. Next, look carefully at the pictures of the models and make a prediction.



If I compare model C3 to model C4, then I think Catapult Model (C3 / C4) will throw the tire further.

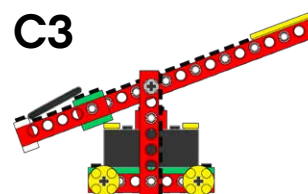

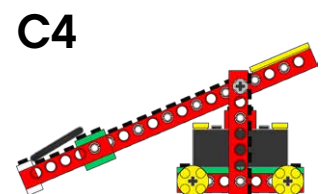



C3	<input type="text"/>
-----------	----------------------

C4	<input type="text"/>
-----------	----------------------

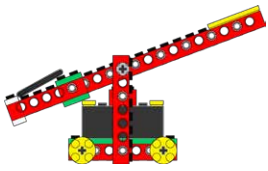
5. Test Catapult Model C3.

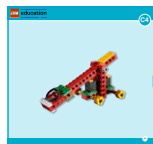

	Test 1	Test 2	Test 3
Measurements 			
Observation Notes 	<hr/> <hr/> <hr/>	<hr/> <hr/> <hr/>	<hr/> <hr/> <hr/>

6. Build Catapult Model C4 and try it out.
Follow Building Instructions C, page 32, step 1.

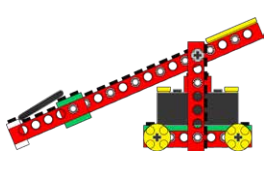

Note: Be careful not to point the catapult toward anybody's face when catapulting the tire.

7. Test Catapult Model C4.

	Test 1	Test 2	Test 3
Measurements 			
Observation Notes 	<hr/> <hr/> <hr/>	<hr/> <hr/> <hr/>	<hr/> <hr/> <hr/>

8. Finally, draw a conclusion and check your prediction.
My tests show that Catapult (C3 / C4) throws the tire further.



C3	
-----------	--

C4	
-----------	--

My prediction was (right / wrong).



	
--	--

	
---	--

Think about different games where you have to aim for a goal—then design your own game where you have to aim precisely with the catapult to score points. You will need to decide what you have to aim for. Try to make rules so that players score different numbers of points for different results.

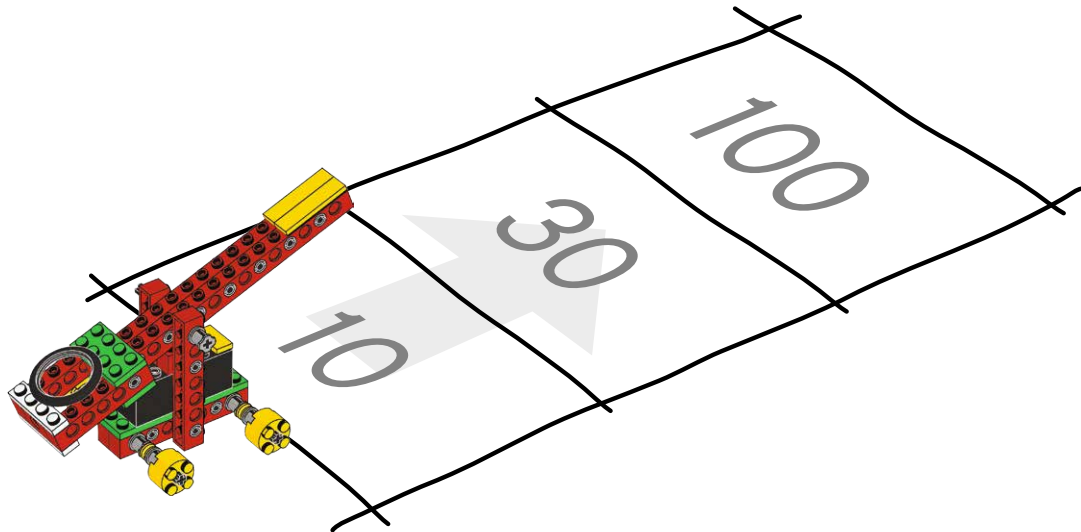

Experiment with different positions in the catapult for the lever beam.

What do you notice?
Explain how the effects are different.
Record your observations.



.....

.....

.....

Create a sign for your game explaining the rules and inviting people to play.

Activity Name: _____

Student Name: _____

Date: _____

How did you do?

Directions: Circle the brick that shows how well you did. The bigger brick, the better you did.

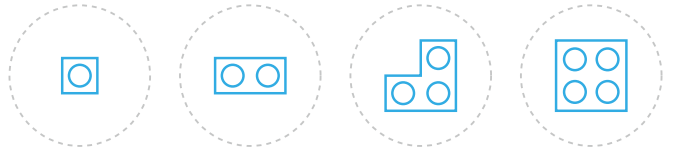
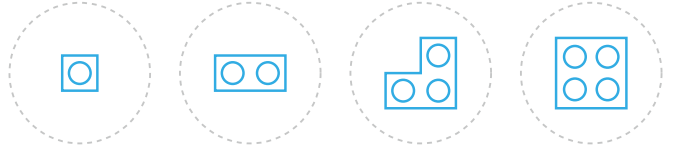
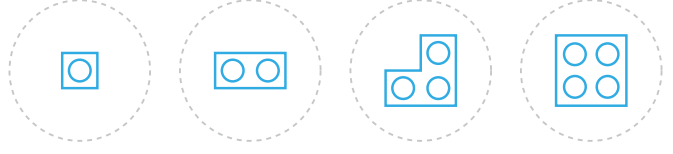
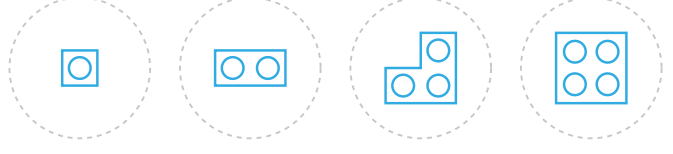
<p>I asked questions to understand what to do. I understood what to do.</p>	
<p>I made predictions and tested my model. I made observations and gathered data.</p>	
<p>I shared my ideas. I listened to my team.</p>	
<p>I used scientific words. I used fair testing.</p>	

Describe what you did (Draw, write or add a photo):

Tell someone what you learned...

Problem-Solving Activity: Railroad Crossing Gate

Student Worksheet



When Sam and Sally visit the fair, certain paths have railroad crossing gates. This is because you can take a train ride around the different areas of the fairground, but you have to be careful crossing the train tracks. On their way to the train ride, Sam and Sally notice that the railroad crossing gate is broken. They want to try to fix it before the train comes.

Let's help Sam and Sally!

Build a railroad crossing gate like the one in the picture.

Your design brief is as follows:

- Build a railroad crossing gate longer than 15 cm (6 inches).
- Build a single stand for the gate to balance on.
- Find a way to make it easy to open and close the gate.

When you have finished, measure the length of your railroad crossing gate, and assess how easy it is to open and close. Assess how well balanced the railroad crossing gate is. What makes it stable?

 **Need help?**
Look at:

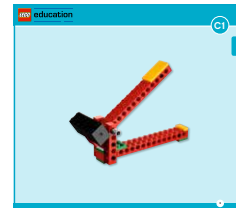

Activity Name: _____

Student Name: _____

Date: _____

How did you do?

Directions: Circle the brick that shows how well you did. The bigger brick, the better you did.

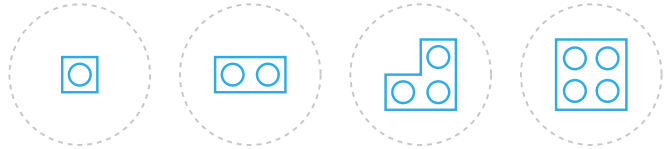
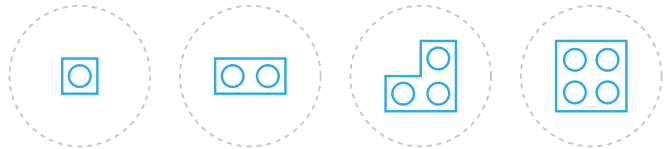
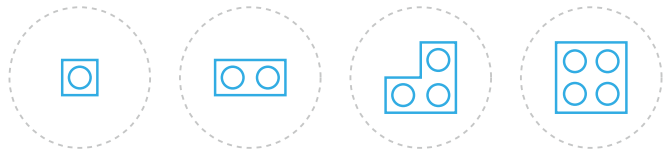
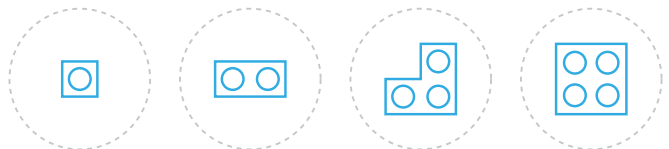
<p>I read the design brief. I understood the problem.</p>	
<p>I built a model to solve the problem. I tested the model and made improvements.</p>	
<p>I shared my ideas. I listened to my team.</p>	
<p>I used scientific words. I can do engineering and design.</p>	

Describe what you did (Draw, write or add a photo):

Tell someone about the problem you solved...

Problem-Solving Activity: Railroad Crossing Gate

Teacher's Notes

Learning objectives:

Students are encouraged to do some research related to the real-life problem they are set to solve and/or the type of simple machine that they are going to use, and to:

- Identify a need or a problem
- Develop explanations using observations
- Test, evaluate, and redesign models

Introduction

To help in the design process, instruct the students to look at the picture on the student worksheet and read the accompanying text. If time and facilities are available, have your students conduct research, and also encourage them to generate ideas and questions by posing problems they must take into account in their design and building processes. Your students could search the Internet to learn more about the appearance, structure, and function of different sorts of gates and railroad crossings.

Students should be reminded of the principle models that they have worked with. It might be a good idea to build principle model C1, a first class lever, to show the technique used.

Discuss the design problem specified in the design brief in class. Try to find several possible general solutions, or use the suggested solution for inspiration if necessary.

Discuss the constraints and functions your students will have to take into account to carry out the design brief. Try to get your students to focus on relevant issues and decisions by asking questions. These might include:

- How will your model look?
Maybe a railroad crossing gate with a lock function, and perhaps a handle for opening and closing it.
- What LEGO® elements do you have available? How can you make the gate balance with only one leg? What could be used as a counterbalance? How will your railroad crossing gate stand on the ground? How long a beam can you use? How do you think you might start building?
- Do you think your railroad crossing gate should open quickly or slowly? Why?

Optional Materials

Materials for enhancing the appearance and functionality of the model: Students can use paper, cardboard and markers to make the railroad crossing gate look more realistic. Additional LEGO elements, if available, may be used to make models more elaborate.

When the model is finished, encourage students to reflect on both the product that they have produced and the processes they have used by:

- Carrying out tests to evaluate the performance of their model
- Reflecting on the design brief
- Recording their design by drawing or taking digital photos

Hint

Most of the images used in the material can be found in the section "Images for Classroom Use", and are easy to display in class.

Need help?

Look at:



Suggested Model Solution

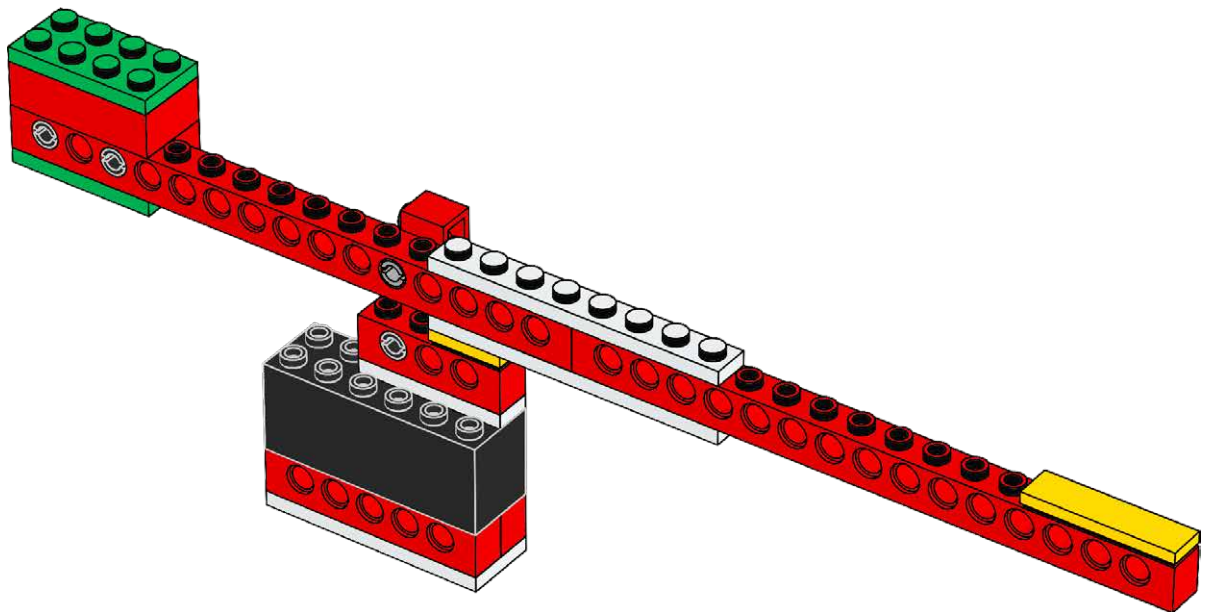
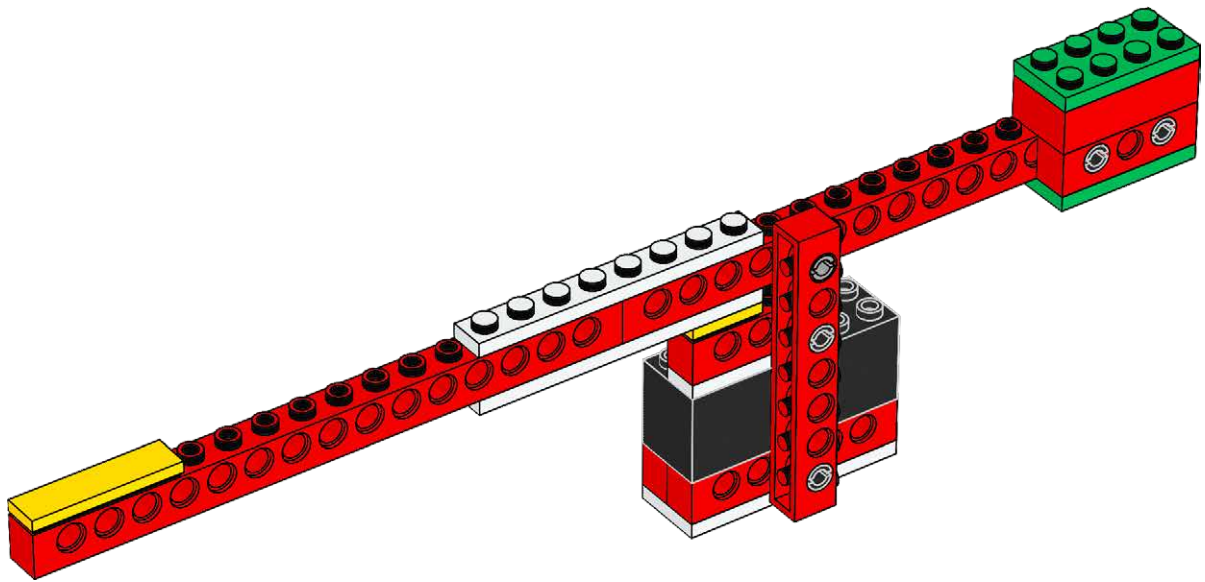

Railroad Crossing Gate

Class: _____

Date: _____

Performance and Learning Targets Linked to the Activity and the Eight Next Generation Science Practices	Name(s)												
Observe the suggested student behaviors while working with the activity. Either use the suggested Emerging (E), Developing (D), Proficient (P), Accomplished (A) proficiency level descriptions or use one relevant to your context.													
Student Performance Targets Linked to the Activity To what degree can the student...?													
Plan, develop a design, and build a railroad crossing gate that meets or exceeds the Design Brief criteria based upon research (E.g. Longer than 15 cm (6 inches), Has a single stand to balance on, Is easy to open and close) (1, 2, 8)													
Design and compare multiple solutions to solve the problem and demonstrate understanding of structure and function of design systems (2, 6)													
Record findings with drawings or digitally to share design ideas with others (2, 5, 7, 8)													
Evaluate and make changes to the model based upon observations and data using fair testing (1, 3, 4, 5, 8)													
Compare models to determine the best solution to the problem (6, 7)													
Selected Student Learning Targets Linked to the Practices To what degree can the student...?													
Ask questions and make observations about what would happen if a variable is changed (1, 3)													
Apply scientific ideas to solve design problems (6)													
Estimate, collect, measure, describe and/or graph quantities to make comparisons across teams and listen to the ideas of others (4, 5, 6, 7, 8)													
Communicate the meaning of the findings with others (E.g. orally, in drawing or writing) (4, 8)													
Discuss evidence that shows how the solution meets the criteria and constraints of the problem (7)													
Optional Student Learning Targets													
Lesson Observational Notes:													

Overview: Pulleys

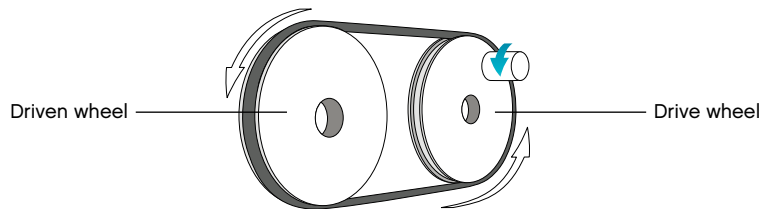

A pulley is most commonly defined as a wheel with a grooved rim for a belt or rope. A belt connecting pulleys can “slip”, meaning that the effort is not being used efficiently. This can happen either when the pulley belt is too loose, or if the pulley wheels differ in size. On the other hand, if the pulley belt is too tight, the belt will create wasteful friction forces on the pulley.

Pulleys can be used to create the following effects:

- To change the orientation of a pulling force
- To change the direction of rotation
- To change the orientation of a rotating movement
- To increase a pulling force
- To increase or decrease the speed of rotation
- To increase turning force, also called torque

Pulleys are found in many machines, such as fan belts, elevators, steam shovels, flagpoles, clothesline pulleys, cranes, old-fashioned wells, blocks and tackle, winches, wire stretchers, and Venetian blinds.



Did you know?

Pulleys connected by a belt have a trade-off between turning force and turning speed. In general terms, you lose in turning force what you gain in turning speed, and vice versa.

Establishing the Concept

We recommend establishing the concept of the simple machine to be worked on. This could be done, for example, by showing students a number of exhibits from the LEGO® set to stimulate their interest. Build a principle model, or show some of the images from Images for Classroom Use, asking questions such as “What do you know about this simple machine?” or “Where do we use this simple machine?” See if students can name any of the objects you show them, and allow time for students to handle them.

Providing the Vocabulary

Students will acquire the necessary vocabulary for the simple machine as they progress through the activities, but it may be useful to introduce certain terms at this stage. Important new vocabulary items are *drive wheel* and *driven wheel*.

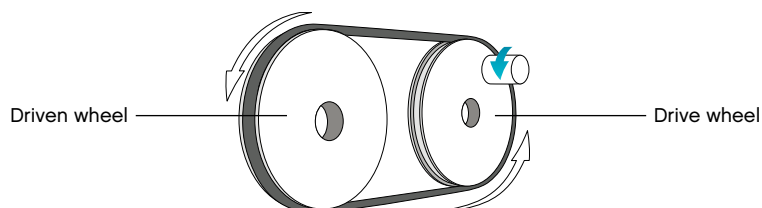

The pulley that is turned by an outside force, such as that from a motor or from a person turning a handle, is called a drive or the drive wheel. When this turns at least one other pulley by a belt, the next pulley is called the driven wheel (or follower).

Understanding the Principles

The principle models are designed to help students understand the principles of the simple machine in focus through hands-on experience before they move on to construct the main models.

The principle models are presented in a logical sequence that will build on students' understanding. The principle models can only be built one at a time from the parts in the set.

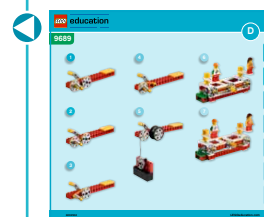
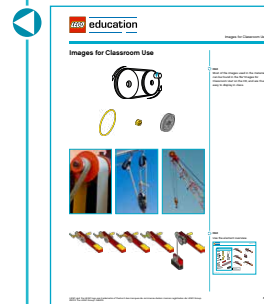
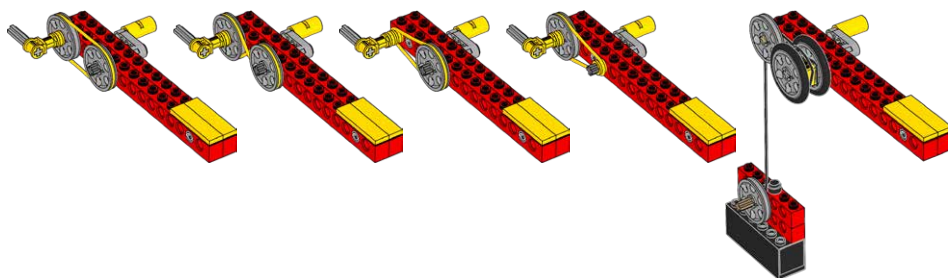

Using the Principle Models

1. The yellow elements indicate where to hold, push, lift, or apply force/effort in handling the principle models. The principle models need to be held correctly for them to work properly.
2. When measuring one turn of the handle, carefully observe the starting place of the handle and be careful to stop at the same position after a full turn.
3. When measuring a full turn of the position marker, carefully observe the starting place of the position marker and be careful to stop at the same position after a full turn. This is especially important when observing the connection between cranking the handle and the number of turns the position marker makes.

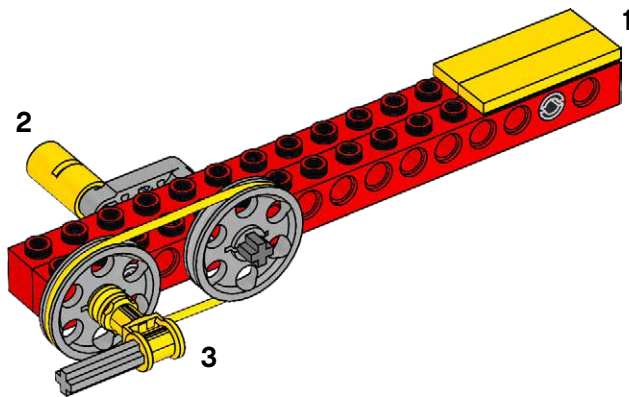

Hint

The principle models can be built as mirror-images for left-handed students.

Hint

It is recommended that students work in pairs; one student can observe the position marker while the other cranks the handle a full turn.

Images for Classroom Use

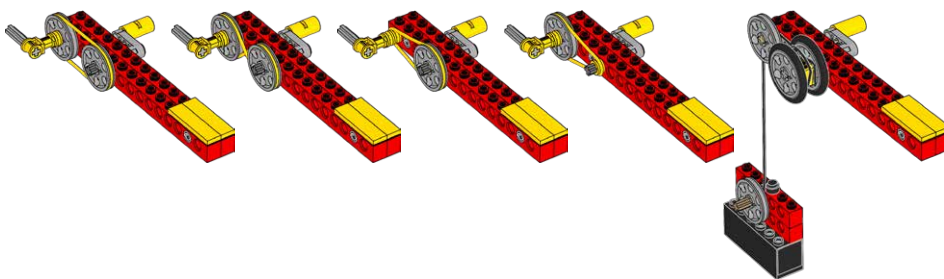
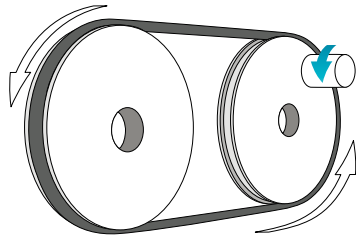

Hint

Most of the images used in the material can be found in the section "Images for Classroom Use", and are easy to display in class.

Hint

Use the element overview.

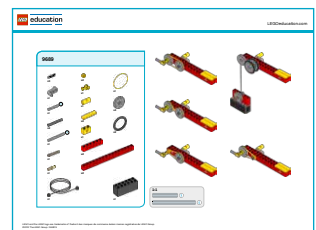

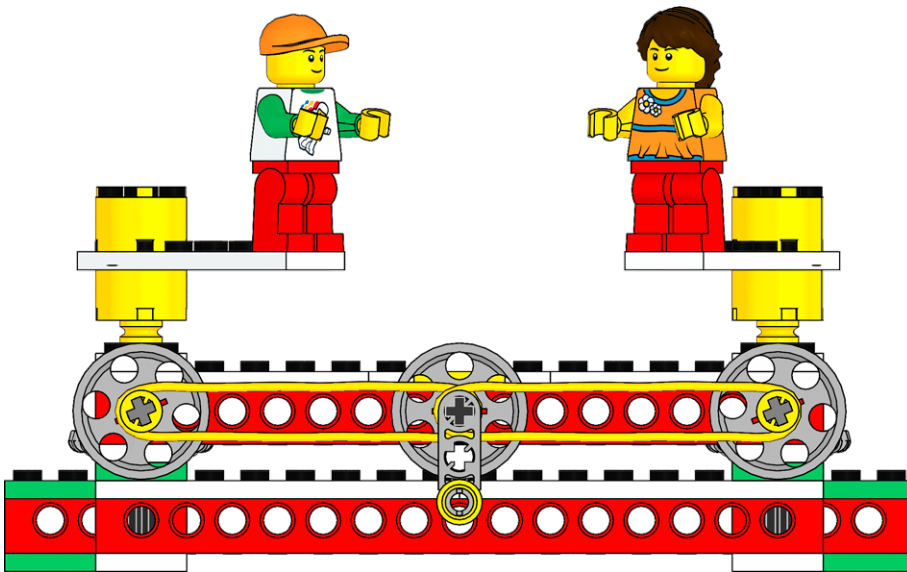

Hint

It is often more practical to sort out the elements that will be needed before starting work on the models.

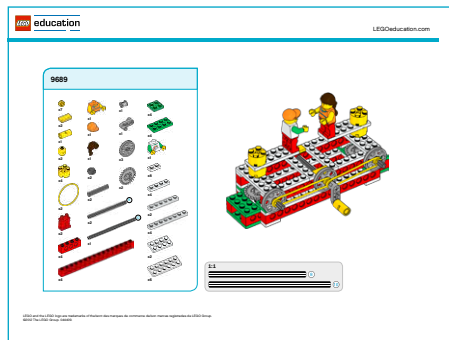
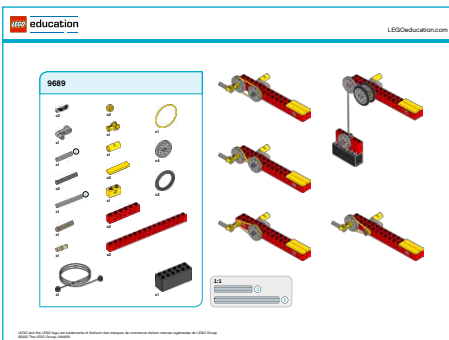

Hint

The element overview can be printed and used as a checklist for students to use when they are taking out and putting away their elements.

Principle Models: Pulleys

Teacher's Notes

Things to talk about:

- What do you know about this simple machine?
- Where do we use this simple machine?
- Why do we use this simple machine?

Relate students' answers to some of the images from "Images for Classroom Use" or find ideas from the "Overview: Pulleys" section to stimulate students' interest.

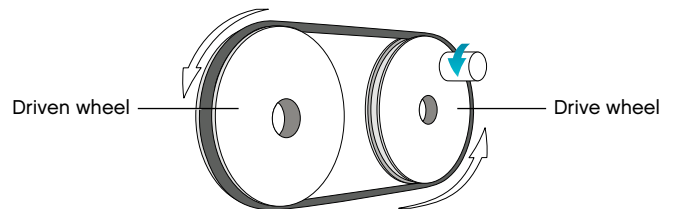

1. Build D1 (Direction of rotation).

Follow Building Instructions D, pages 4 to 8, steps 1 to 8.

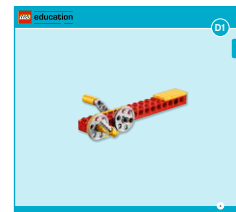

2. Label the pulleys.

Draw lines from the words to the picture of the model.

The drive wheel is the pulley that is turned by an outside effort, in this case your hand. Any pulley that is turned by another pulley is called the driven wheel or follower.

3. Try out the model and make observations.

Note: It is recommended that students work in pairs; one student can observe the position marker while the other cranks the handle a full turn.

Crank the handle one full turn, and count how many times the position marker turns.

One turn of the handle results in one turn of the position marker (the gray axle).

The speed of the rotations of the drive and the driven pulleys are the same, because the wheels have the same diameters.

Observe which way the pulleys turn when you crank the handle, and draw arrows to show the directions they turn in.

The pulley wheels turn in the same direction.

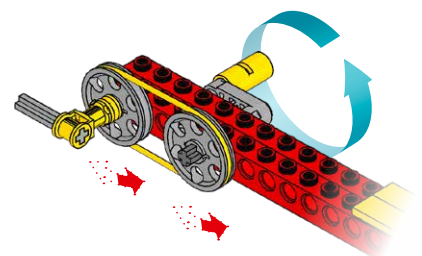
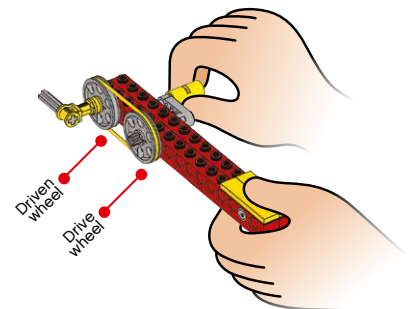

1. Build D2 (Changing direction of rotation).

Follow Building Instructions D, page 10, step 1.

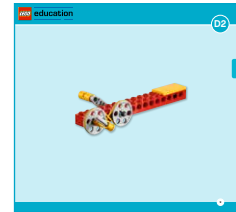
**2. Label the pulleys.**

Draw lines from the words to the picture of the model.

The drive wheel is the pulley that is turned by an outside effort, in this case your hand. Any pulley that is turned by another pulley is called the driven wheel or follower.

3. Try out the model and make observations.

Crank the handle one full turn, and count how many times the position marker turns.

One turn of the handle results in one turn of the position marker (the gray axle).

The speed of the rotations of the drive and the driven wheels are the same, because the wheels have the same diameters.

Observe which way the pulleys turn when you crank the handle, and draw arrows to show the directions they turn in.

The pulley wheels turn in opposite directions, because the pulley belt is twisted.

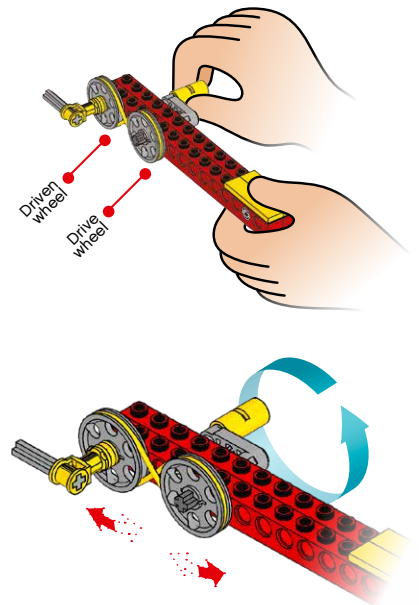
**1. Build D3** (Increasing speed of rotation).

Follow Building Instructions D, pages 12 to 16, steps 1 to 7.

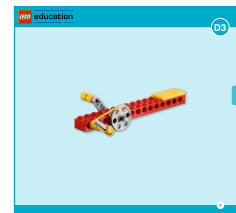
**2. Label the pulleys.**

Draw lines from the words to the picture of the model.

The drive wheel is the pulley that is turned by an outside effort, in this case your hand. Any pulley that is turned by another pulley is called the driven wheel or follower.

3. Try out the model and make observations.

Crank the handle one full turn, and count how many times the position marker turns.

One turn of the handle (the large drive wheel) results in three turns of the smaller driven wheel. This ratio of 1:3 (or 1/3) is called the gearing up ratio. Increasing speed increases the speed of rotation but decreases the force, and the belt can slip.

Observe which way the pulleys turn when you crank the handle, and draw arrows to show the directions they turn in.

The pulley wheels turn in the same direction.

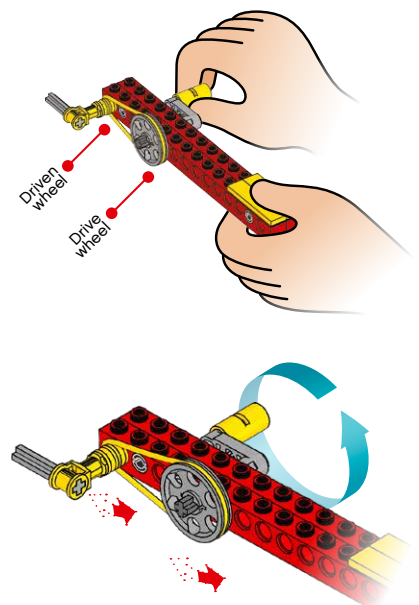

1. Build D4 (Decreasing speed of rotation).

Follow Building Instructions D, pages 18 to 22, steps 1 to 8.

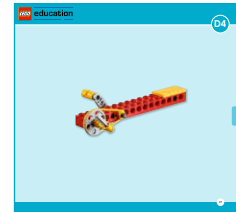

2. Label the pulleys.

Draw lines from the words to the picture of the model.

The drive wheel is the pulley that is turned by an outside effort, in this case your hand. Any pulley that is turned by another pulley is called the driven wheel or follower.

3. Try out the model and make observations.

Count how many times the handle has to turn for the position marker to turn once. *Three turns of the handle (the small driver) results in one turn of the large driven wheel. This ratio of 3:1 (or 3/1) is called the gearing down ratio. Decreasing speed decreases the speed of rotation but increases the force, and the belt can slip.*

Observe which way the pulleys turn when you crank the handle, and draw arrows to show the directions they turn in.

The pulley wheels turn in the same direction.

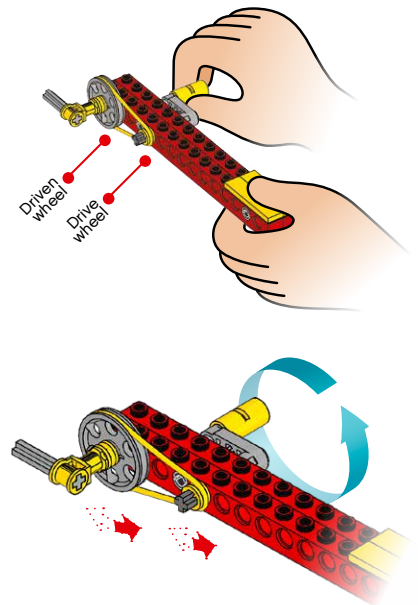

1. Build D5 (Fixed pulley).

Follow Building Instructions D, pages 24 to 32, steps 1 to 10.

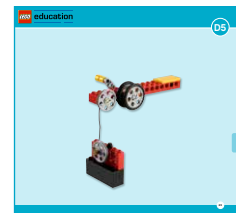

2. Label the pulley.

Draw a line from the word to the picture of the model.

A fixed pulley is made rigid or fastened so that it cannot be moved.

3. Try out the model and make observations.

Observe the directions of movement in the line when the model is used to lift a load.

Mark the direction of movement of the line with arrows, from the load to the fixed pulley and from the fixed pulley to the winch. Continue from where the first arrow is drawn on the model.

This model shows a single fixed pulley. This merely changes the direction of motion, which students will notice if the arrows are drawn correctly.

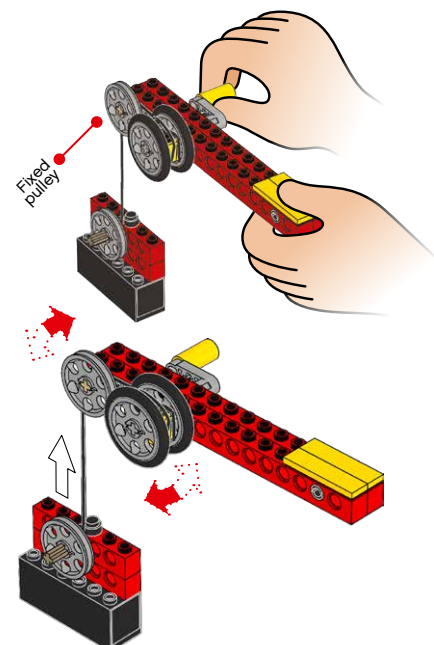

Name(s): _____

Date and subject: _____

Principle Models: Pulleys

Student Worksheet

Things to talk about:

- What do you know about this simple machine?
- Where do we use this simple machine?
- Why do we use this simple machine?

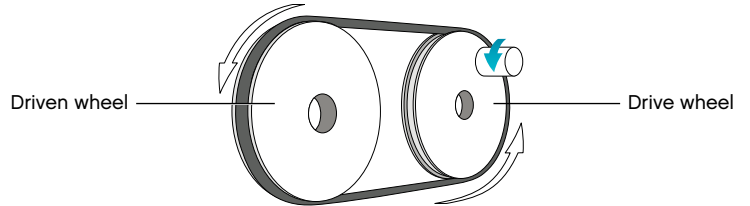

1. Build D1 (Direction of rotation).

Follow Building Instructions D, pages 4 to 8, steps 1 to 8.

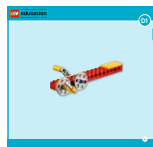

2. Label the pulleys.

Draw lines from the words to the picture of the model.



Driven wheel



Drive wheel

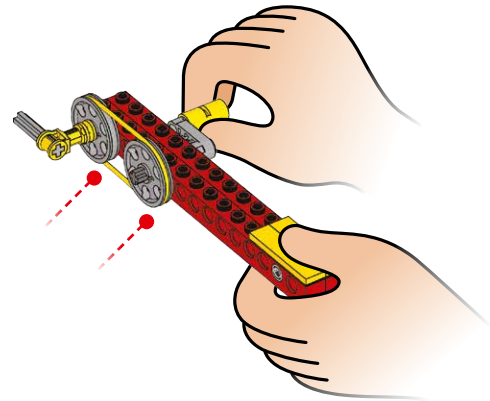

3. Try out the model and make observations.

Crank the handle one full turn, and count how many times the position marker turns.

Write your answer here:



.....



Observe which way the pulleys turn when you crank the handle, and draw arrows to show the directions they turn in.

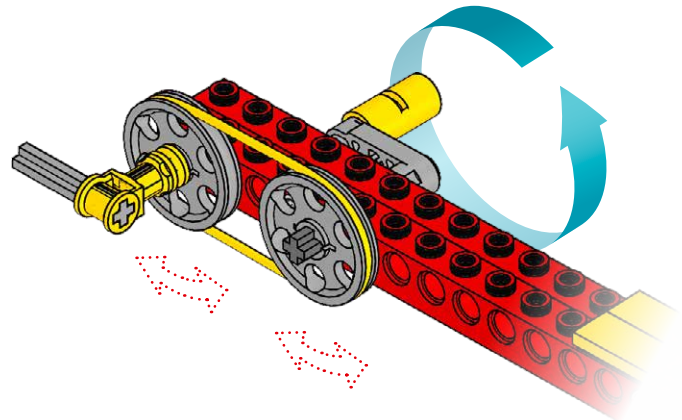

1. **Build D2** (Changing direction of rotation).
Follow Building Instructions D, page 10, step 1.



2. **Label the pulleys.**
Draw lines from the words to the picture of the model.

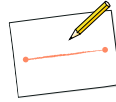

Driven wheel ●
Drive wheel ●

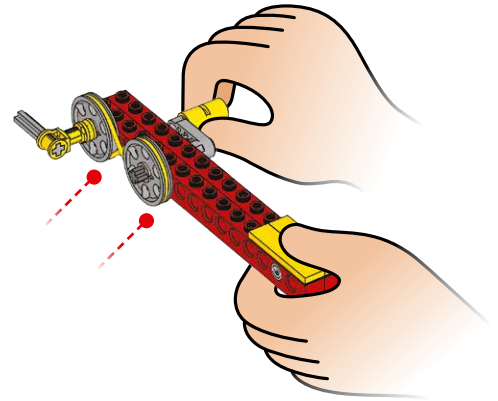

3. **Try out the model and make observations.**
Crank the handle one full turn, and count how many times the position marker turns.
Write your answer here:



.....

Observe which way the pulleys turn when you crank the handle, and draw arrows to show the directions they turn in.

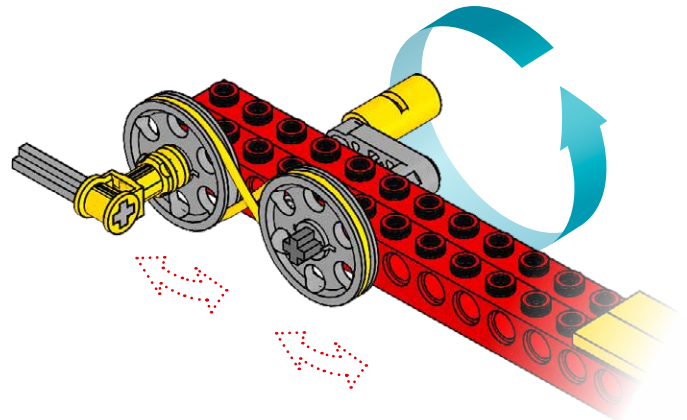

1. **Build D3** (Increasing speed of rotation).
Follow Building Instructions D, pages 12 to 16, steps 1 to 7.



2. **Label the pulleys.**
Draw lines from the words to the picture of the model.



Driven wheel ●
Drive wheel ●

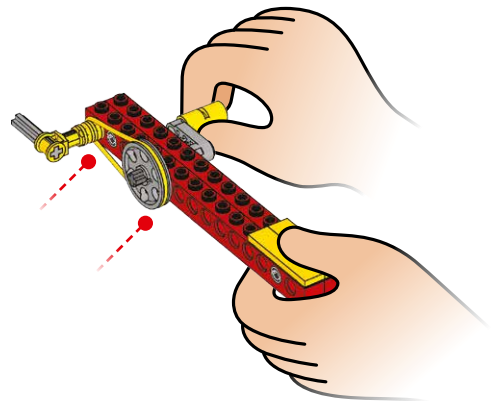

3. **Try out the model and make observations.**
Crank the handle one full turn, and count how many times the position marker turns.
Write your answer here:



.....

Observe which way the pulleys turn when you crank the handle, and draw arrows to show the directions they turn in.

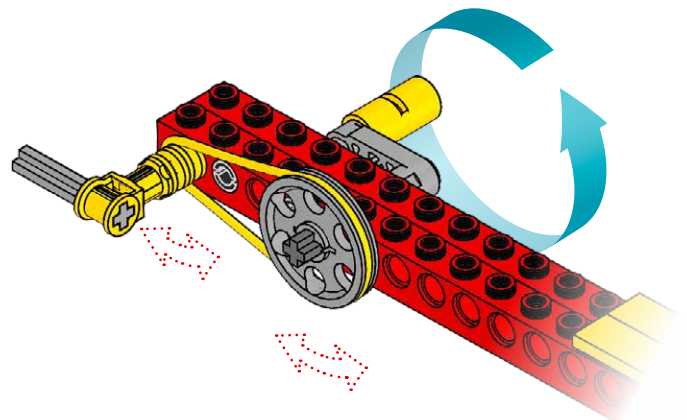

- Build D4 (Decreasing speed of rotation).**
Follow Building Instructions D, pages 18 to 22, steps 1 to 8.



- Label the pulleys.**
Draw lines from the words to the picture of the model.



Driven wheel ●
Drive wheel ●

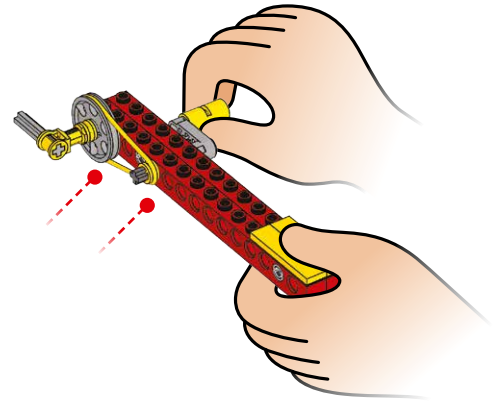

- Try out the model and make observations.**
Count how many times the handle has to turn for the position marker to turn once.
Write your answer here:



.....

Observe which way the pulleys turn when you crank the handle, and draw arrows to show the directions they turn in.

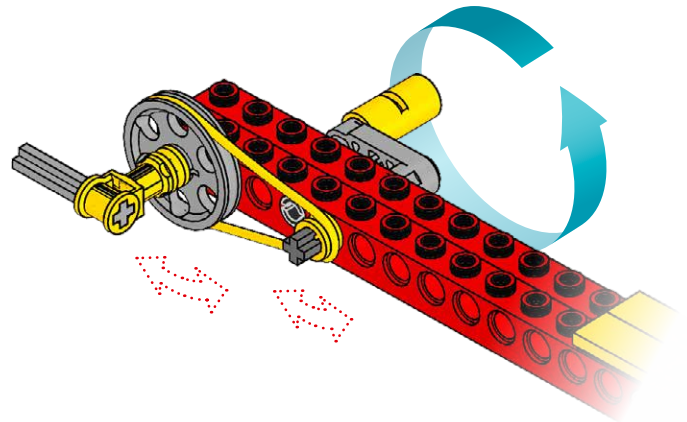

- Build D5 (Fixed pulley).**
Follow Building Instructions D, pages 24 to 32, steps 1 to 10.



- Label the pulley.**
Draw a line from the word to the picture of the model.



Fixed pulley ●

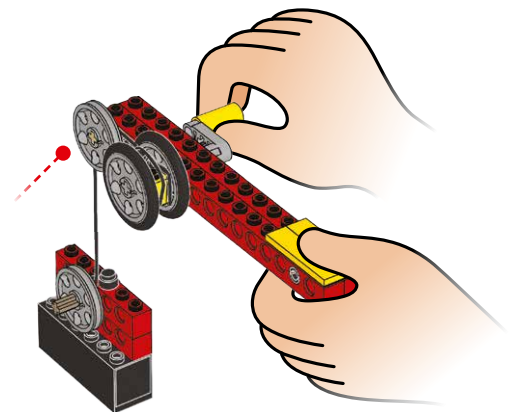

- Try out the model and make observations.**
Observe the directions of movement in the line when the model is used to lift a load.



Mark the direction of movement of the line with arrows, from the load to the fixed pulley and from the fixed pulley to the winch. Continue from where the first arrow is drawn on the model.

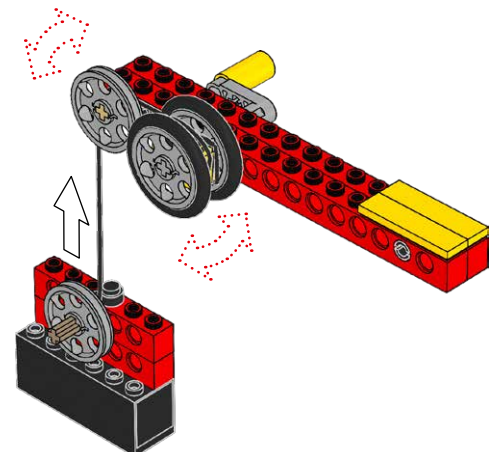

Main Activity: Crazy Floors

Teacher's Notes

Learning Objectives

In this activity students will build and test models that use the following techniques associated with pulleys:

- Decreasing speed of rotation
- Increasing speed of rotation
- Direction of rotation
- Changing direction of rotation

To perform this activity, students should be familiar with the following vocabulary associated with pulleys:

- Drive wheel
- Driven wheel
- Slip

If students have already worked with the principle models, they will already have observed pulleys, and the terms used in this activity should be familiar. Predictions should now be easier to make based on the observations made earlier. If the students have not worked on the principle models, then additional time will be needed, for example to introduce and explain the technical vocabulary used. If additional guidance is required, please turn to the “Overview: Pulleys” or “Principle Models” sections.

Materials Required

- 9689 LEGO® Education Simple Machines Set

◀ 9689



Connect



Hint

Most of the images used in the material can be found in the section "Images for Classroom Use", and are easy to display in class.

Sam and Sally love going to the fair. There is a fun attraction where you have to have good balance. The floors are crazy! They move at different speeds of rotation and in different directions. It is fun turning and trying not to get dizzy or fall down.

Are you good at keeping your balance?
 Have you ever seen floors move?
 Which simple machine is needed for Crazy Floors to turn?

Let's build Crazy Floors!

Construct

1. First, build Crazy Floors Model D6 and make it turn.

Follow Building Instructions D, pages 34 to 54, steps 1 to 22.

When Crazy Floors Model D6 has been built, check the following:

- *Crank the yellow handle to make the crazy floors turn.*
- *Make sure Sam and Sally are attached securely.*

Note: Make sure Sam and Sally are placed as shown on the model.

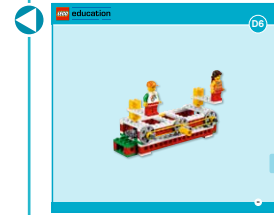
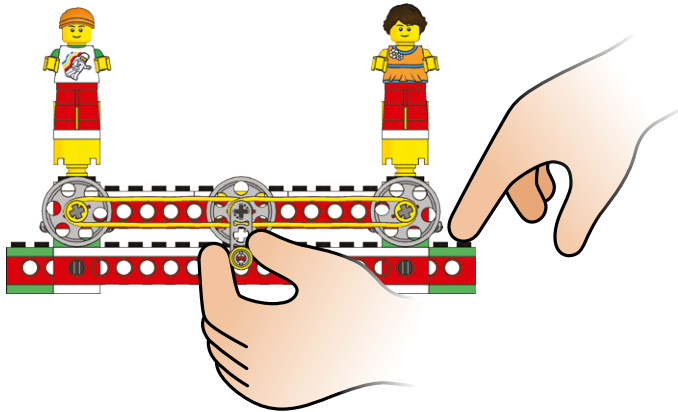

Hint

Students should be reminded that the drive wheel is the pulley turned by an outside effort, in this case your hand cranking the yellow handle.

Contemplate

2. Count the number of pulley wheels on the model.



There are seven pulley wheels built into the model; three large gray pulley wheels and four small yellow pulley wheels.

3. Then look carefully at the pictures of the models and compare Crazy Floors Model D6 to Crazy Floors Model D7.

- Circle what is different.
- What do you notice? Explain how the models are different.

Students should notice the difference in the way the pulleys are arranged on model D6 compared to model D7.

4. Next, look carefully at the pictures of the models and make a prediction.

If I compare model D6 to model D7, then I think Crazy Floors Model (D6/D7) will show the larger difference in turning (speed of rotations) between Sam's side and Sally's side.

Encourage students to discuss the effects the different pulley arrangements have on the crazy floors in their own words. For the prediction, the correct answer is model D7, as it will show a difference in the speed of rotation of the crazy floors on each side of the model. Model D6 has a ratio of 1:1 and both sides of the model will move (turn) at the same speed. However, it does not matter whether students get the answer right or wrong at this point, only that they should make a prediction that can be checked later.

5. Test Crazy Floors Model D6.

- If you want Sam or Sally to make a full turn, how many times must you crank the handle?

Have students observe the starting point of the handle and both Sam's and Sally's starting positions on the crazy floors. Encourage them to try more than once, to ensure that their observations are correct. Students must write their answer in the blank box beside the handle.

The students will have to crank the handle approximately four times for Crazy Floors Model D6 to turn once, but due to slip answers may vary. If students have worked with the principle models for gears, they should be made aware that the angled gearing below the crazy floors enables the rotary motion to be transmitted through a 90-degree angle.

Note: *If possible, keep an example of Crazy Floors Model D6 for students to compare with Crazy Floors Model D7.*

Did you know?

The inside diameter of a small pulley wheel is 5.8 mm (≈ 0.22 in.).



The inside diameter of a large pulley wheel is 22 mm (≈ 0.8 in.).

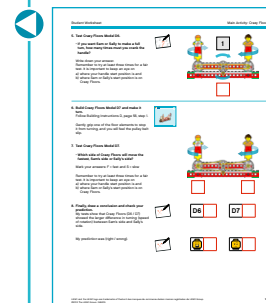
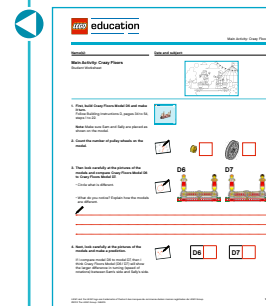
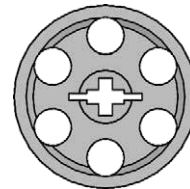

6. Build Crazy Floors Model D7 and make it turn.

Follow Building Instructions D, page 56, step 1.

Gently grip one of the floor elements to stop it from turning, and you will feel the pulley belt slip.

Encourage students to identify parts while they are testing the model. Students can be made aware of "slip" (see Glossary) by gently gripping the floor element to prevent it from turning, as this causes the attached pulley belt to slip.

7. Test Crazy Floors Model D7.

- Which side of Crazy Floors will move the fastest, Sam's side or Sally's side?

Have students pay attention to the starting positions of both the handle and the minifigures. Encourage them to try more than once, to ensure that their observations are correct. Students must write an F for fast and an S for slow. The different pulley arrangements produce different speeds of rotation for Sam and Sally. The drive wheel is attached to the handle, and there is thus a gearing up pulley arrangement to the side where Sam stands. Sam turns at a much faster pace (= F, for fast) than the gearing down pulley arrangement on the side where Sally stands, which turns at a much slower (= S, for slow) pace.

8. Finally, draw a conclusion and check your prediction.

Crazy Floors Model D7 has the larger difference in the speed of rotation of the crazy floors because of the different pulley arrangements.

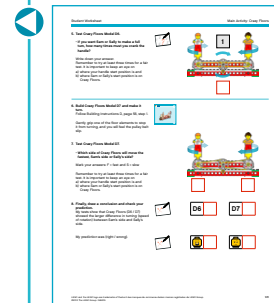

Continue

Students are encouraged to explore the pulley arrangements illustrated on the student worksheet and to record their observations.

Note: *There are no building instructions included to guide students through the Continue phase, other than the illustrated suggestions on the student worksheet.*

Encourage your students to discuss the effects the pulley arrangement will have on Crazy Floors in their own words, prompting them with questions such as:

- Describe what happened when you turned the handle.
- How many times did you have to turn the handle to make the crazy floors turn once? Why do you think that was?
- Describe how the model works.
- What did you do to make sure your observations were correct?

It is suggested that students should draw items where they find pulleys used in everyday machines and mechanisms. For inspiration read or show the “Overview: Pulleys” section.

Optional

With more advanced students, you might consider introducing compound belt drives. Pulley wheels of two different sizes on the same axle can be connected to other pulley wheels to build more extensive gearing down (and gearing up) arrangements.

Hint

Most of the images used in the material can be found in the section “Images for Classroom Use”, and are easy to display in class.

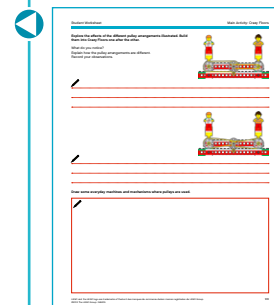

Crazy Floors

Class: _____

Date: _____

Performance and Learning Targets Linked to the Activity and the Eight Next Generation Science Practices Observe the suggested student behaviors while working with the activity. Either use the suggested Emerging (E), Developing (D), Proficient (P), Accomplished (A) proficiency level descriptions or use one relevant to your context.	Name(s)													
Student Performance Targets Linked to the Activity To what degree can the student...?														
Adequately build or expand the Crazy Floors model(s) with help or independently using the Building Instruction (1, 2, 3, 6)														
Use the model to demonstrate and share understanding of science terms and make predictions about the use of pulleys (E.g. speed and rotation relationships) (1, 3, 4, 5, 8)														
Use prior knowledge of machines to describe orally or in writing scientific problems that can be solved using pulley systems (1, 6, 8)														
Make changes or create a new model design in order to create a more advanced model based on tests and data (2, 3, 4, 6)														
Use Crazy Floors worksheets to record and analyze data collected from the model investigation (3, 4, 5)														
Selected Student Learning Targets Linked to the Practices To what degree can the student...?														
Ask questions and make observations about what would happen if a variable is changed (1, 3)														
Demonstrate ability to use fair testing of models and make adjustments based upon test data and measurements (3, 4, 6)														
Test different model designs of the same object to determine which one better meets the criteria (3)														
Estimate, collect, measure, describe and/or graph quantities to make comparisons across teams and listen to the ideas of others (4, 5, 6, 7, 8)														
Communicate the meaning of the findings with others (E.g. orally, in drawing or writing) (4, 8)														
Optional Student Learning Targets														
Lesson Observational Notes:														

Name(s): _____

Date and subject: _____

Main Activity: Crazy Floors

Student Worksheet

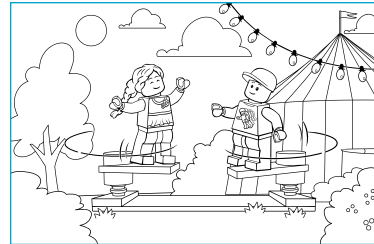

1. First, build Crazy Floors Model D6 and make it turn.

Follow Building Instructions D, pages 34 to 54, steps 1 to 22.



Note: Make sure Sam and Sally are placed as shown on the model.

2. Count the number of pulley wheels on the model.





3. Then look carefully at the pictures of the models and compare Crazy Floors Model D6 to Crazy Floors Model D7.

• Circle what is different.



• What do you notice? Explain how the models are different.

D6

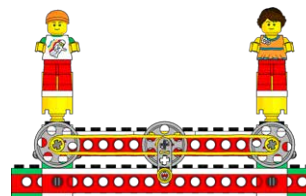

D7

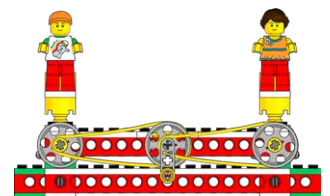

.....

.....

.....

4. Next, look carefully at the pictures of the models and make a prediction.



D6	
-----------	--

D7	
-----------	--

If I compare model D6 to model D7, then I think Crazy Floors Model (D6 / D7) will show the larger difference in turning (speed of rotations) between Sam's side and Sally's side.

5. Test Crazy Floors Model D6.



- If you want Sam or Sally to make a full turn, how many times must you crank the handle?

Write down your answer.

Remember to try at least three times for a fair test. It is important to keep an eye on

- where your handle start position is
- where Sam or Sally's start position is on Crazy Floors.

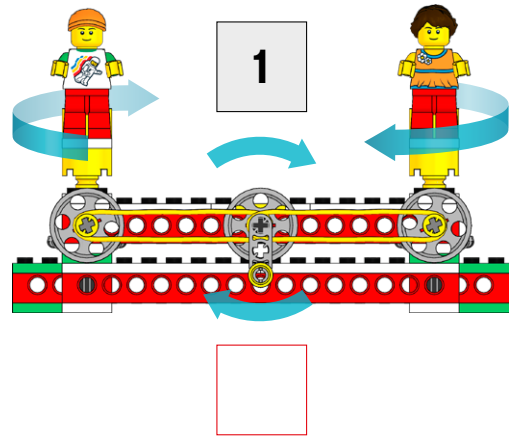

6. Build Crazy Floors Model D7 and make it turn.

Follow Building Instructions D, page 56, step 1.



Gently grip one of the floor elements to stop it from turning, and you will feel the pulley belt slip.

7. Test Crazy Floors Model D7.

- Which side of Crazy Floors will move the fastest, Sam's side or Sally's side?

Mark your answers: F = fast and S = slow

Remember to try at least three times for a fair test. It is important to keep an eye on

- where your handle start position is
- where Sam or Sally's start position is on Crazy Floors.

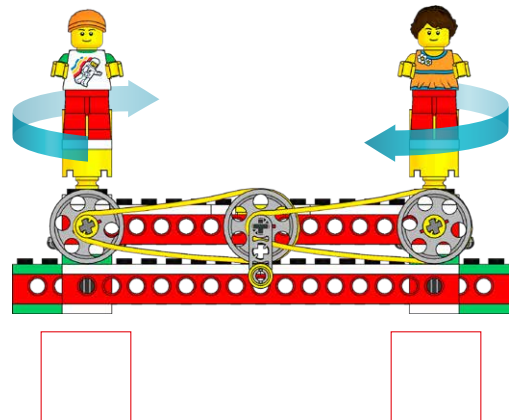

8. Finally, draw a conclusion and check your prediction.

My tests show that Crazy Floors (D6 / D7) showed the larger difference in turning (speed of rotation) between Sam's side and Sally's side.





D6	
-----------	--

D7	
-----------	--

My prediction was (right / wrong).



	
--	--

	
---	--

Activity Name: _____

Student Name: _____

Date: _____

How did you do?

Directions: Circle the brick that shows how well you did. The bigger brick, the better you did.

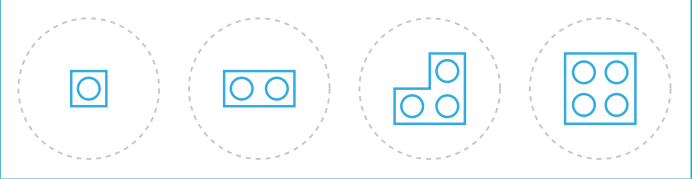
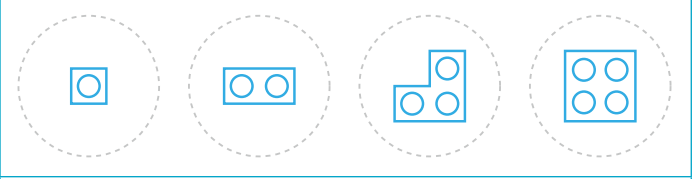
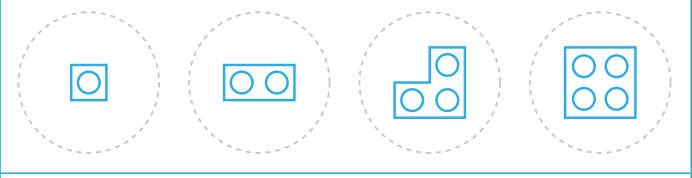
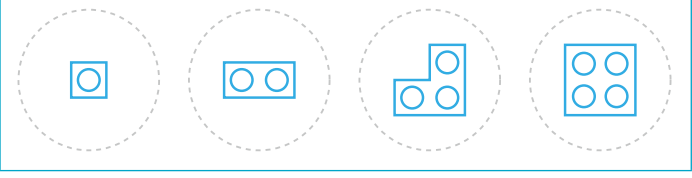
<p>I asked questions to understand what to do. I understood what to do.</p>	
<p>I made predictions and tested my model. I made observations and gathered data.</p>	
<p>I shared my ideas. I listened to my team.</p>	
<p>I used scientific words. I used fair testing.</p>	

Describe what you did (Draw, write or add a photo):

Tell someone what you learned...

Problem-Solving Activity: Crane

Student Worksheet



When the fair is packing up to leave town, Sam and Sally enjoy watching a large crane lifting some of the heavy attractions. Sam and Sally want to try to build a crane and pretend they are part of the working crew at the fair.

Let's help Sam and Sally!

Build a crane like the one in the picture.

Your design brief is as follows:

- Build a crane that balances well.
- Use a fixed pulley on the crane.
- Build a mechanism that makes the winding mechanism stay locked.

When you have finished, test your crane. How well does your lock system work? How much of a load can your crane lift? Assess how easily the crane can move the load and how well it stays stable. What makes the load easy or difficult to move?

 **Need help?**
Look at:

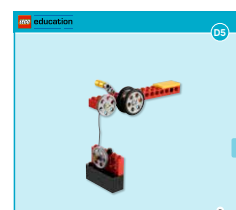
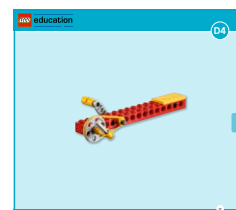
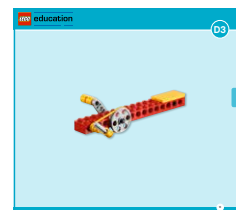
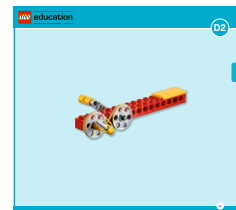
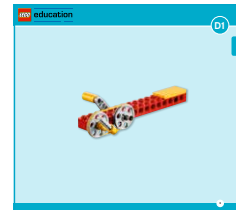

Activity Name: _____

Student Name: _____

Date: _____

How did you do?

Directions: Circle the brick that shows how well you did. The bigger brick, the better you did.

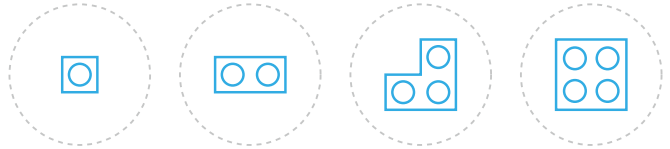
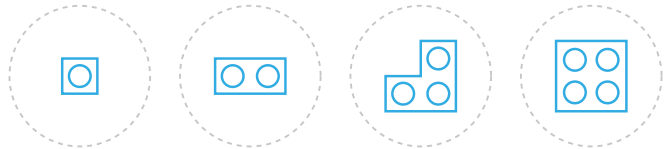
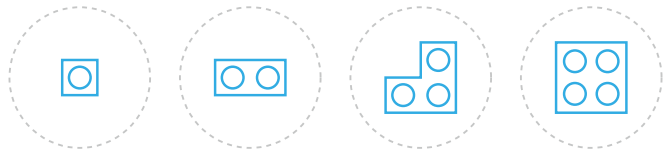
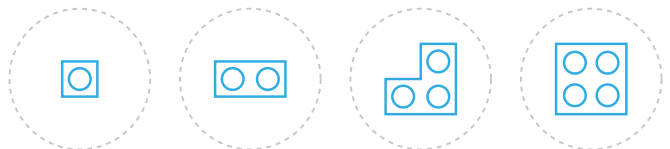
<p>I read the design brief. I understood the problem.</p>	
<p>I built a model to solve the problem. I tested the model and made improvements.</p>	
<p>I shared my ideas. I listened to my team.</p>	
<p>I used scientific words. I can do engineering and design.</p>	

Describe what you did (Draw, write or add a photo):

Tell someone about the problem you solved...

Problem-Solving Activity: Crane

Teacher's Notes

Learning objectives:

Students are encouraged to do some research related to the real-life problem they are set to solve and/or the type of simple machine that they are going to use, and to:

- Identify a need or a problem
- Develop explanations using observations
- Test, evaluate, and redesign models

Introduction

To help in the design process, instruct the students to look at the picture on the student worksheet and read the accompanying text. If time and facilities are available, have your students conduct research, and also encourage them to generate ideas and questions by posing problems they must take into account in their design and building process. Your students could search the Internet to learn more about the appearance, structure, and function of different sorts of cranes, and about how a block and tackle can be used as a lock mechanism.

Students should be reminded of the principle models that they have worked with. It might be a good idea to build principle model D5 (Fixed pulley) to show the technique used.

Discuss the design problem specified in the design brief in class. Try to find several possible general solutions, or use the suggested solution for inspiration if necessary.

Discuss the constraints and functions your students will have to take into account to carry out the design brief. Try to get your students to focus on relevant issues and decisions by asking questions. These might include:

- How will your model look?
Maybe a crane, shaped like a tower, and perhaps a handle for lifting the load, with lock mechanism operated by another handle. Or maybe simply a pawl and ratchet mechanism.
- What LEGO® elements do you have available? How can you balance your crane? What could be used as a counterbalance? What can you use for a fixed pulley? How do you think you might start building?
- Should your crane lift quickly or slowly, do you think? Why?

Optional Materials

Materials for enhancing the appearance and functionality of the model. Additional LEGO elements, if available, may be used to make models more elaborate.

When the model is finished, encourage students to reflect on both the product that they have produced and the processes they have used by:

- Carrying out tests to evaluate the performance of their model
- Reflecting on the design brief
- Recording their design by drawing or taking digital photos

Hint

Most of the images used in the material can be found in the section “Images for Classroom Use”, and are easy to display in class.

Need help?

Look at:



Suggested Model Solution

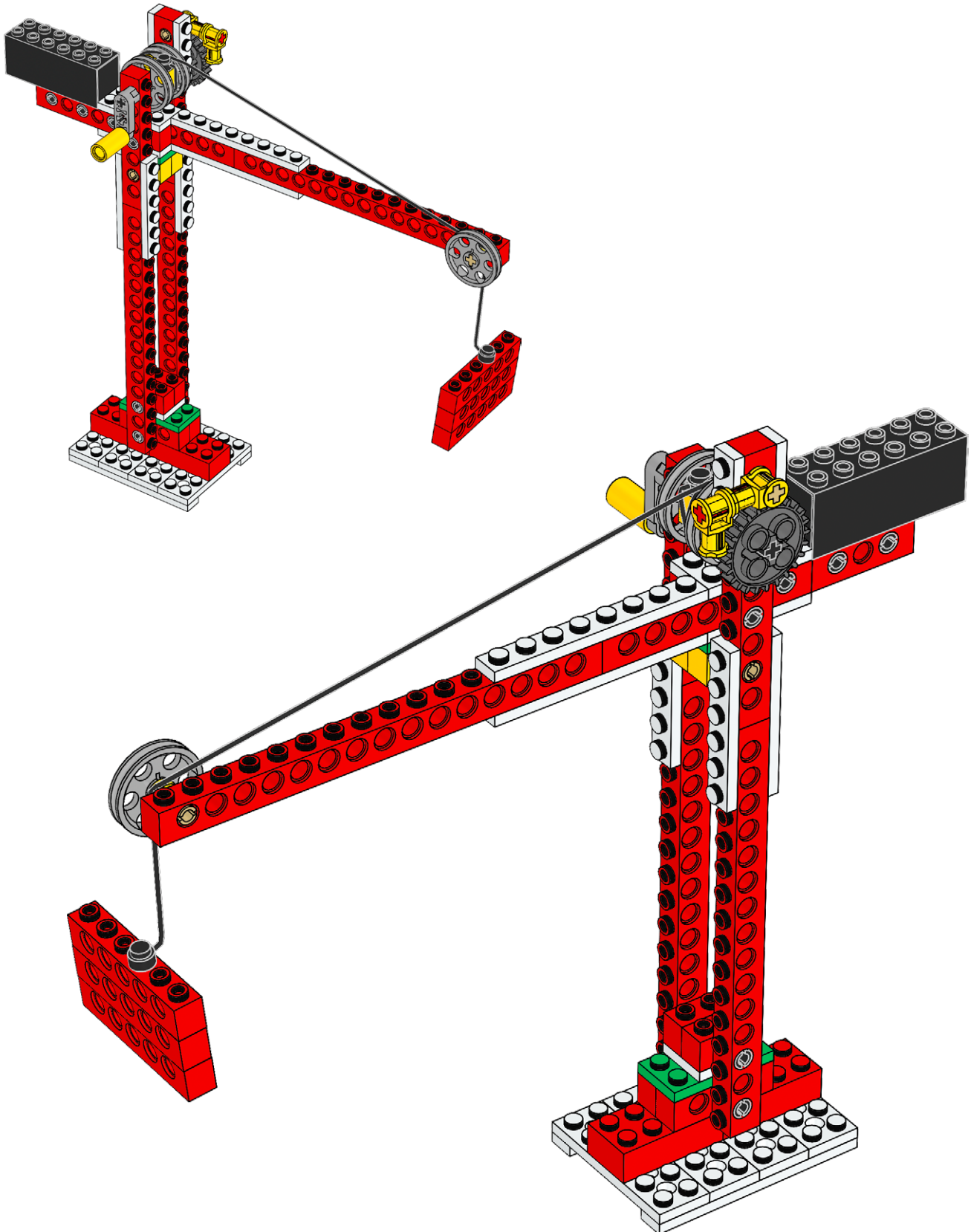

Crane

Class: _____





Date: _____

Performance and Learning Targets Linked to the Activity and the Eight Next Generation Science Practices	Name(s)											
Observe the suggested student behaviors while working with the activity. Either use the suggested Emerging (E), Developing (D), Proficient (P), Accomplished (A) proficiency level descriptions or use one relevant to your context.												
Student Performance Targets Linked to the Activity												
To what degree can the student...?												
Plan, develop a design, and build a crane that meets or exceeds the Design Brief criteria based upon research (E.g. Crane balances well, Uses a fixed pulley, The winding mechanism stays locked) (1, 2, 8)												
Design and compare multiple solutions to solve the problem and demonstrate understanding of stability and function of design systems (2, 6)												
Record findings with drawings or digitally to share design ideas with others (2, 5, 7, 8)												
Evaluate and make changes to the model based upon observations and data using fair testing (1, 3, 4, 5, 8)												
Compare models to determine the best solution to the problem (6, 7)												
Selected Student Learning Targets Linked to the Practices												
To what degree can the student...?												
Ask questions and make observations about what would happen if a variable is changed (1, 3)												
Apply scientific ideas to solve design problems (6)												
Estimate, collect, measure, describe and/or graph quantities to make comparisons across teams and listen to the ideas of others (4, 5, 6, 7, 8)												
Communicate the meaning of the findings with others (E.g. orally, in drawing or writing) (4, 8)												
Discuss evidence that shows how the solution meets the criteria and constraints of the problem (7)												
Optional Student Learning Targets												
Lesson Observational Notes:												



Glossary

We have tried to make the glossary as clear and practical as possible without resorting to complex equations and long explanations.

Angle	The space between two lines or planes that intersect; the inclination of one line to another. Measured in degrees or radians.	 A
Axle	A rod through the center of a wheel. An axle provides support for a wheel. If the axle is fastened to the wheel, it can transmit force to the wheel (as an engine makes the wheels of an automobile move).	
Belt	A continuous band stretched around two pulley wheels so one can turn the other. It is usually designed to slip if the driven wheel suddenly stops turning.	 B
Compound gearing	A combination of gears and axles where at least one axle has two gears of different sizes. Compound gearing results in very big changes to the speed or force of the output compared to the input.	 C
Counter-balance	A force often provided by the weight of an object used to reduce or remove the effects of another force. A crane uses a large concrete block on the short arm of its jib to counter the unbalancing effect of the load of the other, longer, arm.	
Crank	An arm or handle connected to a shaft (or axle) at right angles, enabling the shaft to be turned easily.	
Drive gear/pulley	A gear or pulley that is turned by an applied force. In a machine, usually the part (a gear, pulley, lever, crank, or axle) where the force first comes into the machine.	 D
Driven gear/pulley	Usually a gear wheel or pulley that is turned by another gear wheel or pulley. Also called a follower.	
Effort	The force or amount of force that is put into a machine.	 E

Fair testing	Measuring the performance of a machine or model by testing and comparing its performance more than once.
First class lever	(see Lever, first class)
Fixed pulley	(see Pulley, fixed)
Follower	(see Driven gear/pulley)
Force	A push or a pull.
Friction	A force that resists the movement of one object in contact with another. Also the resistance met by an object when moving over or turning against another object. Friction makes a moving object tend to slow down and eventually stop unless additional force is applied, e.g., when a sledge is pulled across snow. Friction often wastes a lot of energy, reducing the efficiency of a machine.
Fulcrum	Another word for a pivot (see Pivot).
Gear	A gear is a toothed wheel. A way to classify gears is by the number of teeth they have, e.g., an 8-tooth gear or a 40-tooth gear. Gears can be used to transfer force, to increase or reduce speed of rotation, and to change the direction of rotary motion. The teeth of gears mesh together to transmit movement.
Gear, at an angle	(see Gear, crown)
Gear, crown	A crown gear is a specialized gear wheel with teeth protruding to one side (looking like a crown). Because of its special teeth, a crown gear can mesh with an ordinary gear at a 90-degree angle.
Gearing down	An arrangement in which a small drive gear turns a larger driven gear, resulting in a slowing down of the turning. Gearing down produces a more powerful turning force.
Gearing up	An arrangement in which a large drive gear turns a small driven gear, resulting in a speeding up of the turning. Gearing up reduces the turning force.
Grip	The grip between two surfaces depends on the amount of friction between them. Tires grip dry road surfaces better than wet road surfaces.
Idler	A gear wheel that is turned by a drive gear and that turns another driven gear. It does not transform the forces in the machine, but affects direction of rotation of the driven gear.

 **F**
 **G**
 **I**

Lever	A bar that pivots or rotates about a fixed point when a force (effort) is applied.
Lever, first class	The pivot is between the effort and the load. This lever changes the direction of the effort force, and can change the amount of effort needed to lift a load. A long effort arm and short load arm amplify the force at the load arm, e.g. when prying the lid off a can of paint.
Lever, second class	The load is between the effort and the pivot. This lever does not change the direction of the effort force, but can reduce the amount of effort needed to lift a load, e.g. in a wheelbarrow.
Lever, third class	The effort is between the load and the pivot. This lever does not change the direction of the effort force, but can increase the distance the effort moves a load, e.g. in sweeping with a broom.
Load	An object to be raised or moved. The load is sometimes called the resistance.
Machine and/or Mechanism	A device that makes work either easier or faster to do by changing the size or the direction of effort (force) needed, or by changing the distance through which the effort must move. However, a machine or mechanism cannot increase the amount of work done; if it reduces the effort needed, at the same time it increases the distance the effort has to move. A machine usually contains mechanisms. A mechanism is a simple arrangement of components that transforms the size or direction of a force, and the speed of its output. For example, a lever or two gears meshing are mechanisms.
Mesh	To fit together or to be engaged. The teeth of two gear wheels can mesh if they have the same spacing, and if the gear wheels are brought into contact with each other.
Pawl and ratchet	An arrangement of a block or wedge (pawl) and a gear wheel (ratchet) that lets the gear turn in one direction only.
Pivot	The point around which something turns or rotates, such as the pivot of a lever. The axle or rod supporting the middle of a see-saw is an example of a pivot. The pivot does not always have to be in the middle of the lever. In some types or classes of levers, the pivot point may be at one end, as in a wheelbarrow. See also Fulcrum.
Pulley	A pulley is a simple machine which usually consists of a grooved wheel round which a rope, belt, cable or chain is placed. A pulley is used to transfer force, alter speed of rotation, or to turn another wheel.
Pulley, fixed	Changes the direction of the applied force. A fixed pulley does not move with the load.

 L

 M

 P

Slip or slippage A belt or rope slipping, usually on a pulley wheel as a safety feature.



Torque Turning force, for example from an axle.





LEGO® Element Survey



4x
Brick, 2x2 round, yellow
614324



8x
Plate, 1x2, white
302301

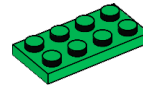

4x
Plate, 2x4, green
302028



4x
Studded beam
with crosshole, 1x2, yellow
4233484



4x
Plate, 1x4, white
371001

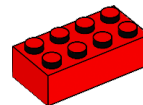

2x
Brick, 2x4, red
300121



2x
Tile, 1x2, yellow
306924

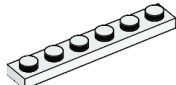

4x
Plate, 1x6, white
366601



4x
Studded beam, 1x2, red
370021



4x
Tile, 1x4, yellow
243124

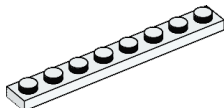

4x
Plate, 1x8, white
346001

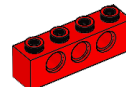

4x
Studded beam, 1x4, red
370121



2x
Tube, 2-module, yellow
4526983



2x
Plate with holes, 2x4, white
370901

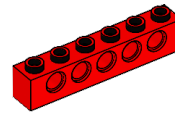

4x
Studded beam, 1x6, red
389421



2x
Angular block
with crosshole, yellow
4107800



6x
Plate with holes, 2x6, white
4527947

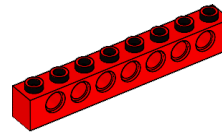

4x
Studded beam,
1x8, red
370221



2x
Cross block, 2-module, yellow
4173666



4x
Plate, 2x2, green
302228

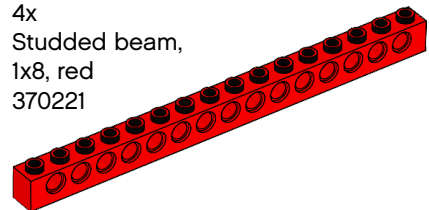

6x
Studded beam, 1x16, red
370321



1x
Minifigure, cap, orange
4583147



2x
Gear, 24-tooth, dark gray
4514558



2x
Connector peg
with friction, 3-module, blue
4514553



2x
Minifigure, head, yellow
4651441

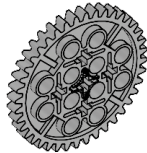

2x
Gear, 40-tooth, gray
4285634



16x
Bushing, gray
4211622



1x
Minifigure, wig, dark brown
4581313



4x
Hub, 24x4, gray
4494222



16x
Bushing, 1/2-module, yellow
4239601



1x
Minifigure, body, white
4549942

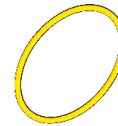

2x
Belt, 33 mm, yellow
4544151



1x
Minifigure, body, orange
4580475



4x
Tire, 30, 4x4, black
281526



4x
Axle, 2-module, red
4142865



2x
Minifigure, legs, red
9342



16x
Connector peg
with friction, black
4121715



2x
Axle, 3-module, gray
4211815



4x
Gear, 8-tooth, dark gray
4514559



10x
Connector peg, gray
4211807



2x
Axle, 4-module, black
370526



2x
Gear, 24-tooth crown, gray
4211434



10x
Connector peg with axle, beige
4666579

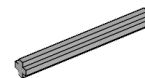

2x
Axle, 5-module, gray
4211639



2x
Axle, 6-module, black
370626



1x
String, 40-module with knobs, black
4528334

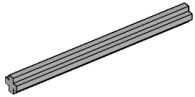

2x
Axle, 7-module, gray
4211805



1x
Weight element, black
73843



2x
Axle, 8-module, black
370726

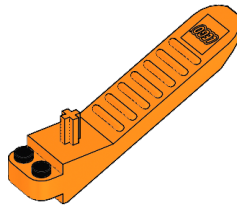

1x
Element separator, orange
4654448

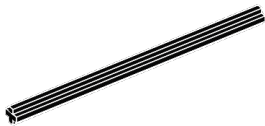

2x
Axle, 10-module, black
373726



2x
Axle with knob,
3-module, dark sand
4566927

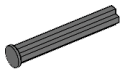

2x
Axle with stop,
4-module, dark gray
4560177



1x
Connector peg, handle, gray
4563045

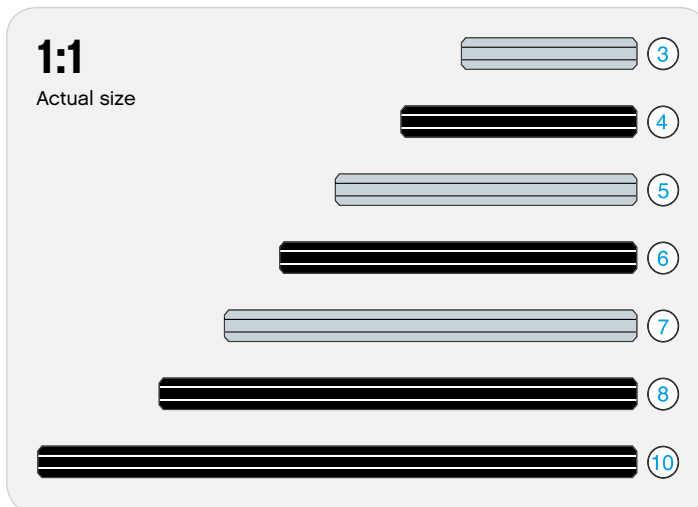

LEGO and the LEGO logo are trademarks of the/sont des marques de commerce du/son marcas registradas de LEGO Group.
©2016 The LEGO Group. All rights reserved. 2017.01.01.

LEGOeducation.com



education