

KNEX® Education

SIMPLE AND COMPOUND MACHINES TEACHER'S GUIDE

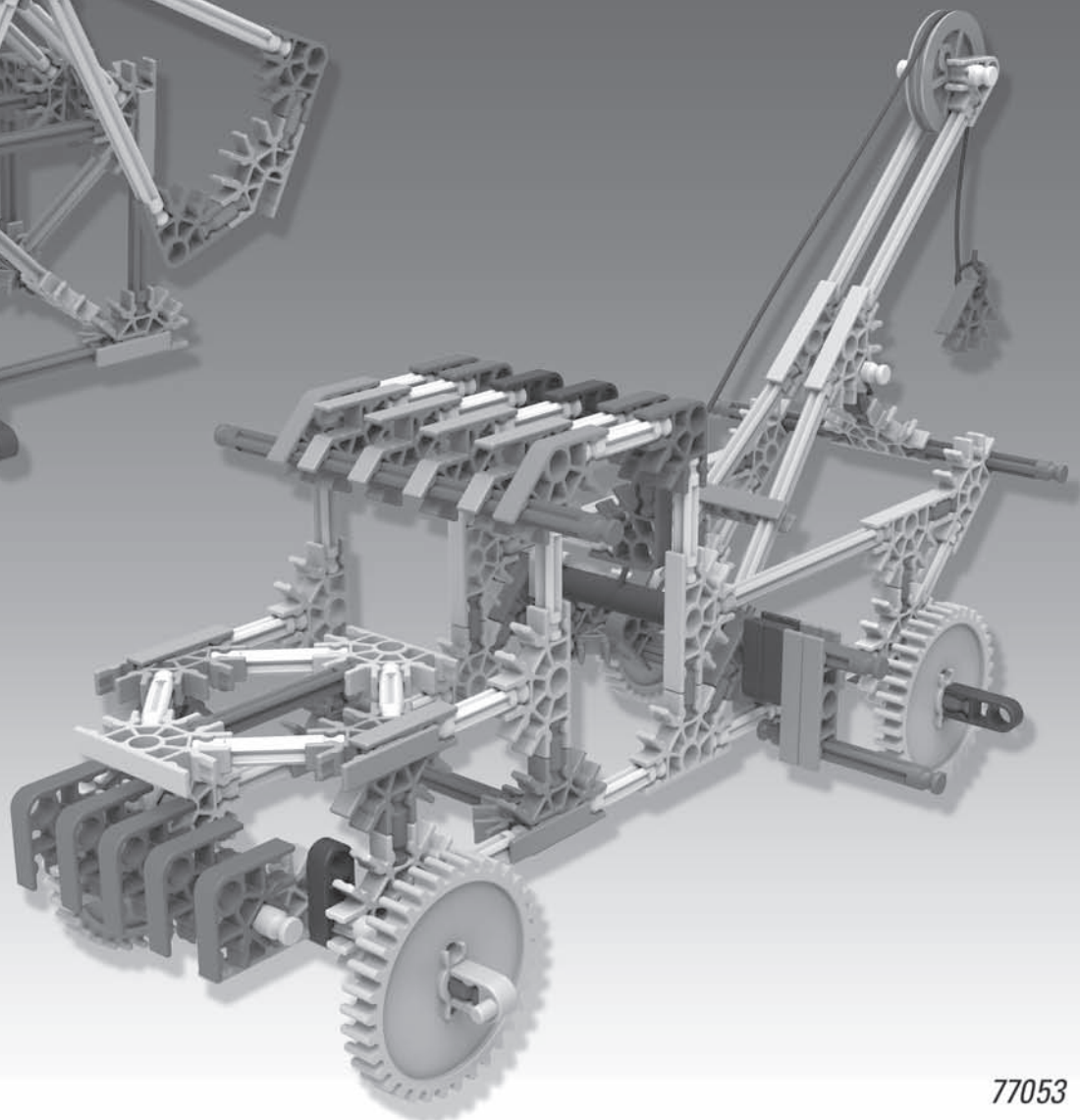

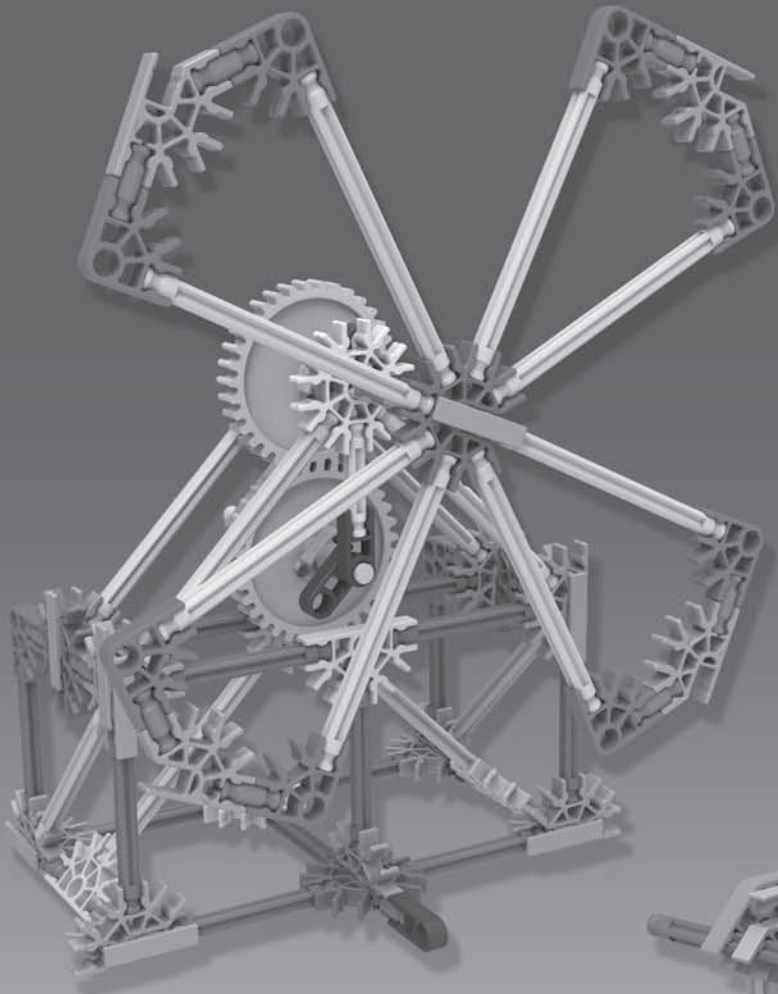
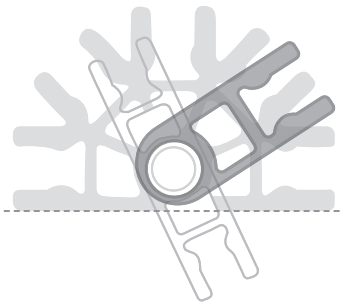

SIMPLE AND COMPOUND MACHINES TEACHER'S GUIDE

V1-10/13
© 2013 K'NEX Limited Partnership Group
and its licensors.

K'NEX Limited Partnership Group
P.O. Box 700
Hatfield, PA 19440-0700

K'NEX is a registered trademark
of K'NEX Limited Partnership Group.
Protected by International Copyright.
All rights reserved.

www.knexeducation.com
abcknex@knex.com
1-888-ABC-KNEX

A NOTE ABOUT SAFETY:

Safety is of primary concern in science and technology classrooms. It is recommended that you develop a set of rules that governs the safe, proper use of K'NEX in your classroom. Safety, as it relates to the use of the Rubber Bands should be specifically addressed.

⚠ CAUTIONS:

Students should not overstretch or overwind their Rubber Bands. Overstretching and overwinding can cause the Rubber Band to snap and cause personal injury. Any wear and tear or deterioration of Rubber Bands should be reported immediately to the teacher. Teachers and students should inspect Rubber Bands for deterioration before each experiment.

Caution students to keep hands and hair away from all moving parts. Never put fingers in moving Gears or other moving parts.



WARNING:

CHOKING HAZARD - Small parts.
Not for children under 3 years.



AVERTISSEMENT:

DANGER D'ÉTOUFFEMENT - Pièces de petite taille.
Ne pas donner aux enfants de moins de 3 ans.

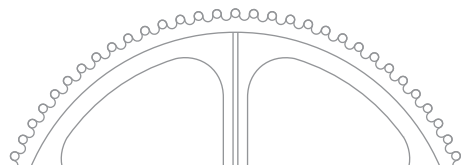

Simple and Compound Machines

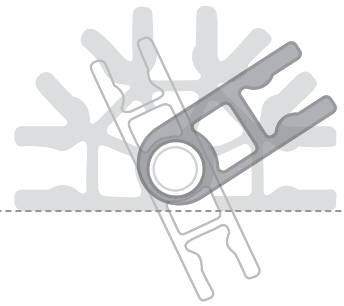

Introduction

*The **K'NEX® Simple and Compound Machines** set and the investigations included in the accompanying **Teacher's Guide** are designed to support middle school physical science and technology curricula. Every attempt has been made to move from standard knowledge-based questioning to investigation, experimentation, and inquiry. Questions associated with each investigation are designed to help students develop higher order thinking skills. In physical science, in particular, this often means incorporating math skills and it also means asking students to analyze, synthesize, and at times, evaluate information.*

This set is intended to help develop students' understanding of the scientific concepts associated with simple and compound machines. Building Instructions are provided for 16 different models. The Teacher's Guide includes Student Inquiry Sheets and Worksheets. Each Inquiry Sheet identifies the objectives of the activity, lists the materials needed to carry out the investigation, presents background information about the machine that is the focus of the activity and sets out the procedure students should follow as they undertake their inquiry. Each Student Worksheet provides space for recording observations, asks additional questions about the machine being investigated and presents challenges that can be used to help students think more deeply about the concepts involved. Teachers should reproduce the Student Inquiry Sheets and Worksheets for their classes. Answers to questions can be found in the Teacher's Answer Sheets which are located at the end of the guide.

Simple and Compound Machines

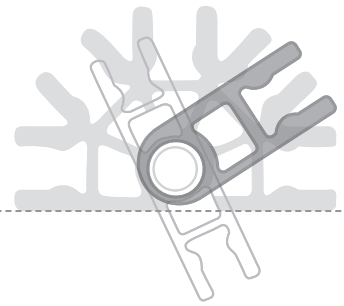
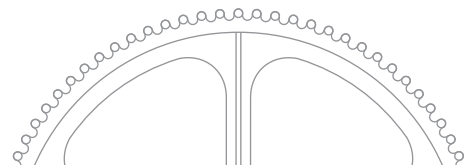
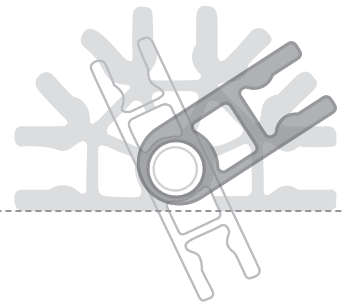

TABLE OF CONTENTS

Teaching Strategies	4
Standards Alignments.	5
Student Inquiry and Worksheets	
Balance.	14
Tow Truck	20
Block and Tackle.	24
Elevator	29
Screwdriver	33
Paddlewheel Boat	38
Dump Truck	44
Inclined Plane	46
Archimedes' Screw	50
Conveyor Belt	54
Rack and Pinion	59
Crank Fan.	63
Carousel	68
Transmission	71
Teacher's Answer Sheets.	75



Simple and Compound Machines



Teaching Strategies:

The best way to administer the investigations provided in this Teacher's Guide will be determined by the teacher, the nature of the classes, the curriculum goals, and national, state, and local standards.

As teachers review their science standards they may gain additional insight into how to further enrich the experiences with simple machines. The following suggestions may also be helpful:

- Use the building portion of each investigation as an introduction for new topics or concepts.
- Use building and investigation portions together as culminating laboratory activities for each simple machine.
- Have students keep a record of their observations and investigations in a science journal, use this as a means of assessment. Alternatively, have students keep student sheets in a designated lab folder for assessment and note keeping purposes. Teachers at Alden Middle School, Alden, New York, who field-tested the Simple and Compound Machines materials with their seventh and eighth grade classes, offered the following practical suggestions:
 - **If the teacher would rather have students record their observations and data in individual science journals, the student worksheets can be omitted.** The classroom teacher can use the questions found on these worksheets as a starting point for guided inquiry. With this approach, the teacher can tailor the investigations to better suit individual classroom or curriculum needs.
- **Laminate building instructions.** This will ensure that the building instructions survive from class to class and from year to year.
- **Have students read before building.** Encourage students to highlight or underline the information that they believe will be most important in the "What's the Story?" section. This helps focus their attention and is a basic study skill.
- **Review often.** Introduce each activity with a review of relevant concepts and vocabulary such as "Work," "Force," "Energy," "Distance," and the relationships between these and the machines that they have already explored. Many of the machine models resemble common items with which students may already be familiar. Encourage students to bring in, or suggest, other machines that are also examples of the machines they are studying in the classroom.

NSES Content Standards Alignments



National Science Education Standards (Grades 5 - 8) <i>Students will develop an understanding of:</i>
UNIFYING CONCEPTS AND PROCESSES
<ul style="list-style-type: none">• <i>Systems, order, and organization</i>
<ul style="list-style-type: none">• <i>Evidence, models, and explanation</i>
<ul style="list-style-type: none">• <i>Change and measurement</i>
<ul style="list-style-type: none">• <i>Form and function</i>
SCIENCE AS INQUIRY
<ul style="list-style-type: none">• <i>Abilities necessary to do scientific inquiry</i>
<ul style="list-style-type: none">• <i>Understanding about scientific inquiry</i>
PHYSICAL SCIENCE
<ul style="list-style-type: none">• <i>Motions and Forces</i>
<ul style="list-style-type: none">• <i>Transfer of Energy</i>
SCIENCE AND TECHNOLOGY
<ul style="list-style-type: none">• <i>Abilities of technological design</i>
<ul style="list-style-type: none">• <i>Understanding about science and technology</i>

Reprinted with permission from 1996 National Science Education Standards by the National Academy of Sciences, Courtesy of the National Academies Press, Washington, D.C.

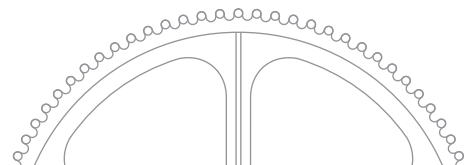

Standards for Technological Literacy: Content for the Study of Technology



Standards for Technological Literacy: Content for the Study of Technology (Grades 3-5) <i>Students will develop an understanding of:</i>
THE NATURE OF TECHNOLOGY
The Core Concepts of Technology
<ul style="list-style-type: none"> • <i>Systems</i> • <i>Processes</i> • <i>Requirements</i>
DESIGN
Engineering Design
<ul style="list-style-type: none"> • <i>Creativity and considering all ideas</i> • <i>Models</i>
The Role of Troubleshooting, Research and Development, Invention and Innovation, and Experimentation in Problem Solving.
<ul style="list-style-type: none"> • <i>Troubleshooting</i> • <i>Experimentation</i>
Standards for Technological Literacy: Content for the Study of Technology (Grades 6-8) <i>Students will develop an understanding of:</i>
THE NATURE OF TECHNOLOGY
The Core Concepts of Technology
<ul style="list-style-type: none"> • <i>Systems</i> • <i>Processes</i> • <i>Requirements</i>
Relationships among technologies and the connections between technology and other fields.
<ul style="list-style-type: none"> • <i>Interaction of systems</i> • <i>Knowledge from other fields of study and technology</i>
DESIGN
Engineering Design
<ul style="list-style-type: none"> • <i>Brainstorming</i> • <i>Modeling, testing, evaluating, and modifying</i>
The Role of Troubleshooting, Research and Development, Invention and Innovation, and Experimentation in Problem Solving.
<ul style="list-style-type: none"> • <i>Troubleshooting</i> • <i>Invention and innovation</i> • <i>Experimentation</i>
ABILITIES OF A TECHNOLOGICAL WORLD
Apply Design Process
<ul style="list-style-type: none"> • <i>Identify criteria and constraints</i> • <i>Test and evaluate</i> • <i>Make a product or system</i>

Used with permission of the ITEEA (www.iteea.org)

NCTM Standards Alignments



National Council of Teachers of Mathematics Education Standards and Expectations for Grades 6 - 8

NUMBER AND OPERATIONS

Instructional programs from pre-kindergarten through grade 12 should enable all students to:

- *Understand numbers, ways of representing numbers, relationships among numbers, and number systems.*
- *Understand meanings of operations and how they relate to one another.*
- *Compute fluently and make reasonable estimates.*

GRADES 3 - 5

NUMBERS AND OPERATIONS

Instructional programs from pre-kindergarten through grade 12 should enable all students to:

- *Understand numbers, ways of representing numbers, relationships among numbers, and number systems.*
- *Understand meanings of operations and how they relate to one another.*
- *Compute fluently and make reasonable estimates.*

Grades 3 - 5 Expectations: In grades 3 - 5 all students should:

Understand numbers, ways of representing numbers, relationships among numbers, and number systems.

- *Understand the place-value structure of the base-ten number system and be able to represent and compare whole numbers and decimals.*
- *Develop understanding of fractions as parts of unit wholes, as parts of a collection, as locations on number lines, and as divisions of whole numbers.*
- *Use models, benchmarks, and equivalent forms to judge the size of fractions.*
- *Recognize and generate equivalent forms of commonly used fractions, decimals, and percents.*

Grades 3 - 5 Expectations: In grades 3 - 5 all students should:

Understand meanings of operations and how they relate to one another.

- *Understand various meanings of multiplication and division.*
- *Understand the effects of multiplying and dividing whole numbers.*
- *Identify and use relationships between operations, such as division as the inverse of multiplication, to solve problems.*

Grades 3 - 5 Expectations: In grades 3 - 5 all students should:

Compute fluently and make reasonable estimates.

- *Develop fluency with basic number combinations for multiplication and division and use these combinations to mentally compute related problems, such as 30×50 .*
- *Develop fluency in adding, subtracting, multiplying, and dividing whole numbers.*
- *Develop and use strategies to estimate computations involving fractions and decimals in situations relevant to students' experience.*
- *Select appropriate methods and tools for computing with whole numbers from among mental computation, estimation, calculators, and paper and pencil according to the context and nature of the computation and use the selected method or tools.*

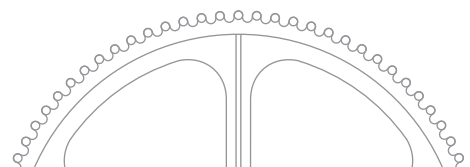



ALGEBRA
Instructional programs from pre-kindergarten through grade 12 should enable all students to:
<ul style="list-style-type: none"> • <i>Understand patterns, relations, and functions.</i>
<ul style="list-style-type: none"> • <i>Represent and analyze mathematical situations and structures using algebraic symbols.</i>
<ul style="list-style-type: none"> • <i>Use mathematical models to represent and understand quantitative relationships.</i>
<ul style="list-style-type: none"> • <i>Analyze change in various contexts.</i>
Grades 3 - 5 Expectations: In grades 3 - 5 all students should:
Understand patterns, relations, and functions.
<ul style="list-style-type: none"> • <i>Represent and analyze patterns and functions, using words, tables, and graphs.</i>
Grades 3 - 5 Expectations: In grades 3 - 5 all students should:
Represent and analyze mathematical situations and structures using algebraic symbols.
<ul style="list-style-type: none"> • <i>Represent the idea of a variable as an unknown quantity using a letter or a symbol.</i>
<ul style="list-style-type: none"> • <i>Express mathematical relationships using equations.</i>
Grades 3 - 5 Expectations: In grades 3 - 5 all students should:
Use mathematical models to represent and understand quantitative relationships.
<ul style="list-style-type: none"> • <i>Model problem situations with objects and use representations such as graphs, tables, and equations to draw conclusions.</i>
Grades 3 - 5 Expectations: In grades 3 - 5 all students should:
Analyze change in various contexts.
<ul style="list-style-type: none"> • <i>Investigate how a change in one variable relates to a change in a second variable.</i>
<ul style="list-style-type: none"> • <i>Identify and describe situations with constant or varying rates of change and compare them.</i>
MEASUREMENT STANDARD
Instructional programs from pre-kindergarten through grade 12 should enable all students to:
<ul style="list-style-type: none"> • <i>Understand measurable attributes of objects and the units, systems, and processes of measurement.</i>
<ul style="list-style-type: none"> • <i>Apply appropriate techniques, tools, and formulas to determine measurements.</i>
Grades 3 - 5 Expectations: In grades 3 - 5 all students should:
Understand measurable attributes of objects and the units, systems, and processes of measurement.
<ul style="list-style-type: none"> • <i>Understand such attributes as length, and select the appropriate type of unit for measuring each attribute.</i>
<ul style="list-style-type: none"> • <i>Understand the need for measuring with standard units and become familiar with standard units in the customary and metric systems.</i>
<ul style="list-style-type: none"> • <i>Carry out simple unit conversions, such as from centimeters to meters, within a system of measurement.</i>
<ul style="list-style-type: none"> • <i>Understand that measurements are approximations and how differences in units affect precision.</i>
DATA ANALYSIS AND PROBABILITY
Instructional programs from pre-kindergarten through grade 12 should enable all students to:
<ul style="list-style-type: none"> • <i>Formulate questions that can be addressed with data and collect, organize, and display relevant data to answer them.</i>
<ul style="list-style-type: none"> • <i>Select and use appropriate statistical methods to analyze data.</i>
<ul style="list-style-type: none"> • <i>Develop and evaluate inferences and predictions that are based on data.</i>
<ul style="list-style-type: none"> • <i>Understand and apply basic concepts of probability.</i>



Grades 3 - 5 Expectations: In grades 3 - 5 all students should: Formulate questions that can be addressed with data and collect, organize, and display relevant data to answer them.
<ul style="list-style-type: none"> • <i>Collect data using observations, surveys, and experiments.</i> • <i>Represent data using tables and graphs such as line plots, bar graphs, and line graphs.</i>
Grades 3 - 5 Expectations: In grades 3 - 5 all students should: Select and use appropriate statistical methods to analyze data
<ul style="list-style-type: none"> • <i>Describe the shape and important features of a set of data and compare related data sets, with an emphasis on how the data are distributed.</i>
Grades 3 - 5 Expectations: In grades 3 - 5 all students should: Develop and evaluate inferences and predictions that are based on data.
<ul style="list-style-type: none"> • <i>Propose and justify conclusions and predictions that are based on data and design studies to further investigate the conclusions or predictions.</i>
GRADE 6
NUMBERS AND OPERATIONS
Grades 6 - 8 Expectations: In grades 6 - 8 all students should: Understand numbers, ways of representing numbers, relationships among numbers, and number systems.
<ul style="list-style-type: none"> • <i>Work flexibly with fractions, decimals, and percents to solve problems.</i> • <i>Understand and use ratios and proportions to represent quantitative relationships.</i> • <i>Develop meaning for integers and represent and compare quantities with them.</i>
Grades 6 - 8 Expectations: In grades 6 - 8 all students should: Understand meanings of operations and how they relate to one another.
<ul style="list-style-type: none"> • <i>Understand the meaning and effects of arithmetic operations with fractions, decimals, and integers.</i>
Grades 6 - 8 Expectations: In grades 6 - 8 all students should: Compute fluently and make reasonable estimates.
<ul style="list-style-type: none"> • <i>Select appropriate methods and tools for computing with fractions and decimals from among mental computation, estimation, calculators or computers, and paper and pencil, depending on the situation, and apply the selected methods.</i>
ALGEBRA
Instructional programs from pre-kindergarten through grade 12 should enable all students to:
<ul style="list-style-type: none"> • <i>Understand patterns, relations, and functions.</i> • <i>Represent and analyze mathematical situations and structures using algebraic symbols.</i> • <i>Use mathematical models to represent and understand quantitative relationships.</i> • <i>Analyze change in various contexts.</i>
Grades 6 - 8 Expectations: In grades 6 - 8 all students should: Understand patterns, relations, and functions.
<ul style="list-style-type: none"> • <i>Represent, analyze, and generalize a variety of patterns with tables, graphs, words, and symbolic rules when possible.</i> • <i>Relate and compare different forms of representation for a relationship.</i>

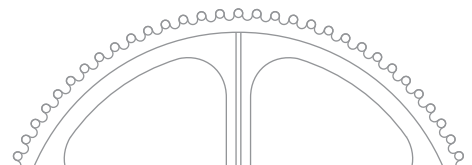



Grades 6 - 8 Expectations: In grades 6 - 8 all students should: Represent and analyze mathematical situations and structures using algebraic symbols.
<ul style="list-style-type: none"> • <i>Develop an initial conceptual understanding of different uses of variables.</i>
<ul style="list-style-type: none"> • <i>Use symbolic algebra to represent situations and to solve problems, especially those that involve linear relationships.</i>
<ul style="list-style-type: none"> • <i>Recognize and generate equivalent forms for simple algebraic expressions and solve linear equations.</i>
Grades 6 - 8 Expectations: In grades 6 - 8 all students should: Use mathematical models to represent and understand quantitative relationships.
<ul style="list-style-type: none"> • <i>Model and solve contextualized problems using various representations, such as graphs, tables, and equations.</i>
Grades 6 - 8 Expectations: In grades 6 - 8 all students should: Analyze change in various contexts.
<ul style="list-style-type: none"> • <i>Use graphs to analyze the nature of changes in quantities in linear relationships.</i>
MEASUREMENT STANDARD
Instructional programs from pre-kindergarten through grade 12 should enable all students to:
<ul style="list-style-type: none"> • <i>Understand measurable attributes of objects and the units, systems, and processes of measurement.</i>
<ul style="list-style-type: none"> • <i>Apply appropriate techniques, tools, and formulas to determine measurements.</i>
Grades 6 - 8 Expectations: In grades 6 - 8 all students should: Understand measurable attributes of objects and the units, systems, and processes of measurement.
<ul style="list-style-type: none"> • <i>Understand both metric and customary systems of measurement.</i>
<ul style="list-style-type: none"> • <i>Understand relationships among units and convert from one unit to another within the same system.</i>
Grades 6 - 8 Expectations: In grades 6 - 8 all students should: Apply appropriate techniques, tools, and formulas to determine measurements.
<ul style="list-style-type: none"> • <i>Select and apply techniques and tools to accurately find length, area, volume, and angle measures to appropriate levels of precision.</i>
DATA ANALYSIS AND PROBABILITY
Grades 6 - 8 Expectations: In grades 6 - 8 all students should: Instructional programs from pre-kindergarten through grade 12 should enable all students to:
<ul style="list-style-type: none"> • <i>Formulate questions that can be addressed with data and collect, organize, and display relevant data to answer them.</i>
<ul style="list-style-type: none"> • <i>Select and use appropriate statistical methods to analyze data.</i>
Grades 6 - 8 Expectations: In grades 6 - 8 all students should: Formulate questions that can be addressed with data and collect, organize, and display relevant data to answer them.
<ul style="list-style-type: none"> • <i>Formulate questions, design studies, and collect data about a characteristic shared by two populations or different characteristics within one population.</i>



PROCESS STANDARDS
Problem Solving
Instructional programs from pre-kindergarten through grade 12 should enable all students to:
<ul style="list-style-type: none"> • <i>Build new mathematical knowledge through problem solving.</i> • <i>Solve problems that arise in mathematics and in other contexts.</i> • <i>Apply and adapt a variety of appropriate strategies to solve problems.</i> • <i>Monitor and reflect on the process of mathematical problem solving.</i>
Reasoning and Proof
Instructional programs from pre-kindergarten through grade 12 should enable all students to:
<ul style="list-style-type: none"> • <i>Recognize reasoning and proof as fundamental aspects of mathematics.</i> • <i>Select and use various types of reasoning and methods of proof.</i>
Communication
Instructional programs from pre-kindergarten through grade 12 should enable all students to:
<ul style="list-style-type: none"> • <i>Organize and consolidate their mathematical thinking through communication.</i> • <i>Communicate their mathematical thinking coherently and clearly to peers, teachers, and others.</i> • <i>Analyze and evaluate the mathematical thinking and strategies of others.</i> • <i>Use the language of mathematics to express mathematical ideas precisely.</i>
Connections
Instructional programs from pre-kindergarten through grade 12 should enable all students to:
<ul style="list-style-type: none"> • <i>Recognize and use connections among mathematical ideas.</i> • <i>Recognize and apply mathematics in contexts outside of mathematics.</i>
Representation
Instructional programs from pre-kindergarten through grade 12 should enable all students to:
<ul style="list-style-type: none"> • <i>Create and use representations to organize, record, and communicate mathematical ideas.</i> • <i>Select, apply, and translate among mathematical representations to solve problems.</i> • <i>Use representations to model and interpret physical, social, and mathematical phenomena.</i>

Standards are reprinted with permission from *Principles and Standards for School Mathematics*, copyright 2000 by the National Council of Teachers of Mathematics (NCTM). All rights reserved. NCTM does not endorse the content or validity of these alignments.

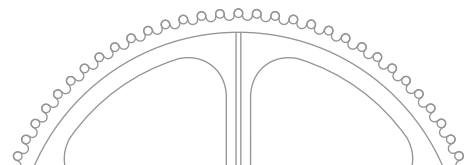

Common Core Standards Alignments



Common Core State Standards for Mathematics in Grades 5 - 8	
MATHEMATICAL PRACTICES - ASSOCIATED WITH MATHEMATICS AT ALL GRADE LEVELS	
1. <i>Make sense of problems and persevere in solving them.</i>	
2. <i>Reason abstractly and quantitatively.</i>	
3. <i>Construct viable arguments and critique the reasoning of others.</i>	
4. <i>Model with mathematics.</i>	
5. <i>Use appropriate tools strategically.</i>	
6. <i>Attend to precision.</i>	
7. <i>Look for and make use of structure.</i>	
8. <i>Look for and express regularity in repeated reasoning.</i>	
GRADE 5	
Operations and Algebraic Thinking	
<ul style="list-style-type: none"> • <i>Write and interpret numerical expressions.</i> • <i>Analyze patterns and relationships.</i> 	
Number and Operations in Base Ten	
<ul style="list-style-type: none"> • <i>Perform operations with multi-digit whole numbers and with decimals to hundredths.</i> 	
Measurement and Data	
<ul style="list-style-type: none"> • <i>Convert like measurement units within a given measurement system.</i> • <i>Represent and interpret data.</i> 	
Geometry	
<ul style="list-style-type: none"> • <i>Graph points on the coordinate plane to solve real-world and mathematical problems.</i> 	
MATHEMATICS GRADE 6	
In Grade 6, instructional time should focus on four critical areas:	
<ul style="list-style-type: none"> • <i>Connecting ratio and rate to whole number multiplication and division and using concepts of ratio and rate to solve problems.</i> • <i>Writing, interpreting, and using expressions and equations.</i> • <i>Developing understanding of statistical thinking.</i> 	
GRADE 6	
Ratios and Proportional Relationships	
<ul style="list-style-type: none"> • <i>Understand ratio concepts and use ratio reasoning to solve problems.</i> 	
The Number System	
<ul style="list-style-type: none"> • <i>Compute fluently with multi-digit numbers and find common factors and multiples.</i> 	
Expressions and Equations	
<ul style="list-style-type: none"> • <i>Apply and extend previous understandings of arithmetic to algebraic expressions.</i> • <i>Reason about and solve one-variable equations.</i> • <i>Represent and analyze quantitative relationships between dependent and independent variables.</i> 	



Statistics and Probability
<ul style="list-style-type: none"> • <i>Develop understanding of statistical variability.</i>
MATHEMATICS GRADE 7
In Grade 7, instructional time should focus on four critical areas:
<ul style="list-style-type: none"> • <i>Developing understanding of and applying proportional relationships.</i> • <i>Developing understanding of operations with rational numbers and working with expressions and linear equations.</i> • <i>Drawing inferences about populations based on samples.</i>
GRADE 7
Ratios and Proportional Relationships
<ul style="list-style-type: none"> • <i>Analyze proportional relationships and use them to solve real-world and mathematical problems.</i>
The Number System
<ul style="list-style-type: none"> • <i>Apply and extend previous understandings of operations with fractions to add, subtract, multiply, and divide rational numbers.</i>
Expressions and Equations
<ul style="list-style-type: none"> • <i>Use properties of operations to generate equivalent expressions.</i> • <i>Solve real-life and mathematical problems using numerical and algebraic expressions and equations.</i>
MATHEMATICS GRADE 8
In Grade 8, instructional time should focus on three critical areas:
<ul style="list-style-type: none"> • <i>Grasping the concept of a function and using functions to describe quantitative relationships.</i>
GRADE 8
Expressions and Equations
<ul style="list-style-type: none"> • <i>Analyze and solve linear equations.</i>
Functions
<ul style="list-style-type: none"> • <i>Define, evaluate, and compare functions.</i> • <i>Use functions to model relationships between quantities.</i>
Statistics and Probability
<ul style="list-style-type: none"> • <i>Investigate patterns of association in bivariate data.</i>

Authors: National Governors Association Center for Best Practices, Council of Chief State School Officers; Title: Common Core State Standards Mathematics; Publisher: National Governors Association Center for Best Practices, Council of Chief State School Officers, Washington D.C.; Copyright Date: 2010

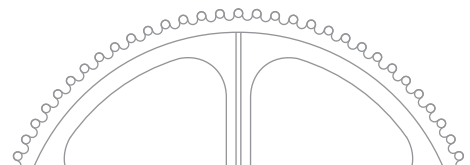

The Balance



Objectives

- To determine experimentally the relationships between effort force, load force, and fulcrum in a first-class lever system.
- To compare the mechanical advantage of different first-class lever systems.
- To design a first-class lever system that uses minimal effort force to balance the greatest load.

Materials

- K'NEX Balance model

The following items are not included in the set:

- Pennies minted after 1982 (approx. 20 - 30)
- 2 paper squares (7.5 cm x 7.5 cm), or weighing boats
- Ruler
- Small paper cup to store the pennies
- Dot stickers or masking tape
- Pen/marker

What's the Story?

Machines allow you to do work faster or more easily. In other words, a machine helps you to do work. Machines can transfer energy, magnify force, multiply speed, or change the direction of a force. They cannot, however, increase work or energy. In most cases, the amount of work put **into** the machine is more than the amount of work produced **by** the machine. Because friction is present in most systems, some energy is changed to heat or sound.

Different types of machines offer different levels of mechanical advantages. Mechanical advantage is the ratio of the **output force**, or force exerted by the machine, to the **input force**, or force applied to the machine. A nail is difficult to pull out of wood with your hand because you cannot apply enough force to the nail to overcome friction. The same small force, however, applied to the end of a claw hammer handle, produces a larger force, applied over a small distance, at the hammer head. The output force of the hammer is large enough to overcome friction, allowing you to pull out the nail.

A hammer is just one example of a lever. A lever is one of six simple machines. There are three classes of **levers**, classified by the arrangement of forces and pivot point. In the investigation below, you will explore a first-class lever. First-class levers are those in which a pivot point, or fulcrum, separates the input force, or effort force, from the output force, or load force.

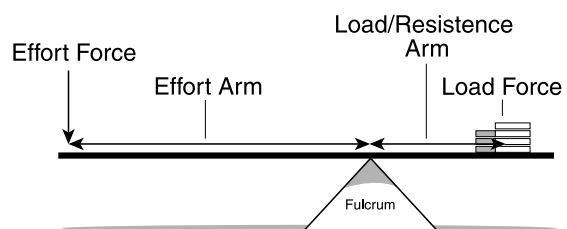

The Key Parts of a First-Class Lever

Fig. 1

What To Do

Part I: All Things Being Equal

1. Build the K'NEX Balance model.
NOTE: You will want to modify the base of the 2 hanging pans in Step 15 so that they can hold a load of pennies. To reduce the spaces in the base, replace the blue Rods with yellow Connectors and small green Rods. (Fig. 2)

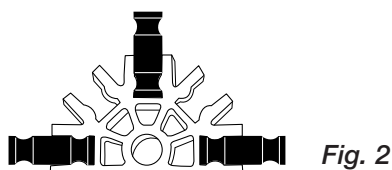

2. Using masking tape, or dot stickers, label one hanging pan as the **effort** force pan (E) and one as the **load** force pan (L).

3. Slide the load force pan (L) into position approximately 3 cm from the end of the balance arm, as shown in Fig. 3.

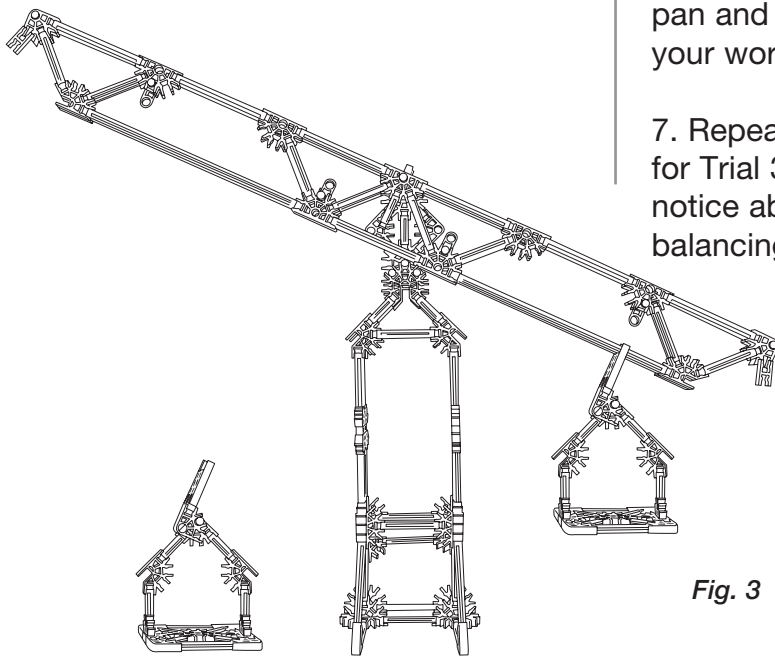

4. On the other side of the fulcrum, attach and then slide the effort pan (E) along the lever until the system is balanced.

5. Measure the distances from the load pan to the fulcrum and from the effort pan to the fulcrum. (Fig. 4) Record these distances as Trial 1 in Table 1, Balance Worksheet.

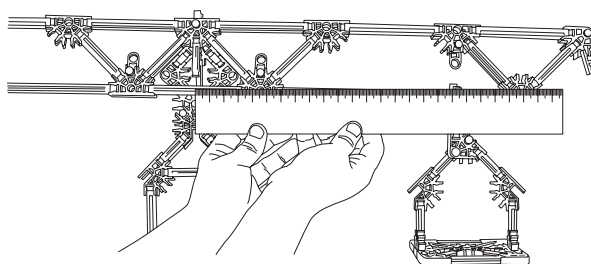

Fig. 4

6. Slide the load pan to a new position along the lever. Slide the effort pan along the lever until the system is balanced again. Measure and record distances between each pan and the fulcrum for Trial 2 on your worksheet.

7. Repeat Step 6, recording distances for Trial 3 in Table 1. What do you notice about your measurements for balancing the system?

Fig. 3



8. Calculate and record the mechanical advantage (MA) for each trial. (The formula for MA, provided in Table 1, is the ratio of effort distance to load distance. In ideal circumstances this is the same as the ratio of output force to input force discussed earlier.)

Part II(a): Unbalanced Forces

1. Slide the **load** pan (L) to the far right of the fulcrum.
2. Measure the distance from the load pan to the fulcrum and record this measurement on your worksheet.
3. Slide the **effort** pan (E) to a position, to the left of the fulcrum, which is **one half the distance** you measured for the load pan in # 2 above. Record this distance on your worksheet.

4. Add enough pennies to the **effort** pan to balance the system. See *Fig. 5* below.

5. Now place four pennies on the **load** pan and observe what happens to the system.

6. Predict the number of pennies that, when added to the effort pan, will return balance to the system. Record your prediction on your worksheet.

7. Add pennies, one at a time, to the **effort** pan until the system is balanced. How many pennies must be added to the effort pan to return balance to the system? Record your result. Do not include the pennies you first added in Step 4 (above) to balance the system.

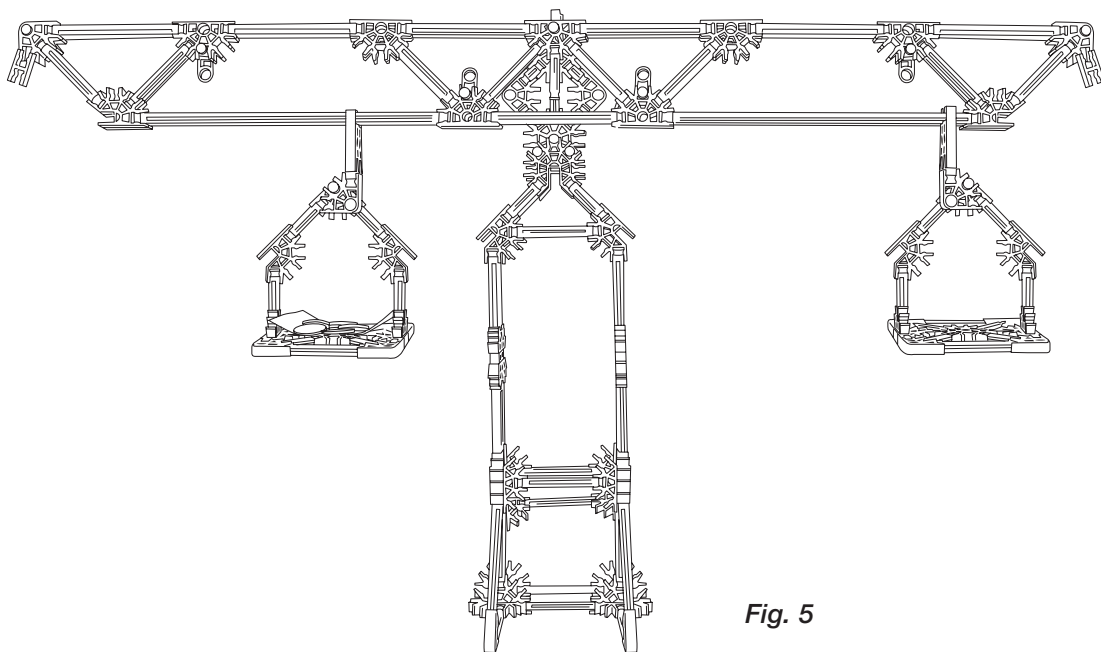

Fig. 5

Part II(b): Unbalanced Forces

1. Remove all the pennies from the effort and load pans.
2. Slide the **effort** pan to the far left of the fulcrum. Measure the distance from the effort pan to the fulcrum and record this measurement on your worksheet.
3. Slide the **load** pan to a position, to the right of the fulcrum, which is **one half the distance** you measured for the effort pan in # 2 above. Record this distance on your worksheet. Add enough pennies to the **load** pan to balance the system. See *Fig. 6* below.
4. Place four more pennies on the **load** pan. Observe what happens to the system.

5. Predict the number of pennies that, when added to the effort pan, will return balance to the system. Record your prediction on the worksheet.

6. Add pennies, one at a time, to the **effort** pan until the system is balanced. Record your result on the worksheet.

7. Using your data from Part II, develop a conclusion that describes the mechanical advantage of a first class lever system. Include evidence from your experimental results and calculations to support your answer. Remember, mechanical advantage is a calculation that indicates how many times the machine multiplies the effort force. Write your conclusion.

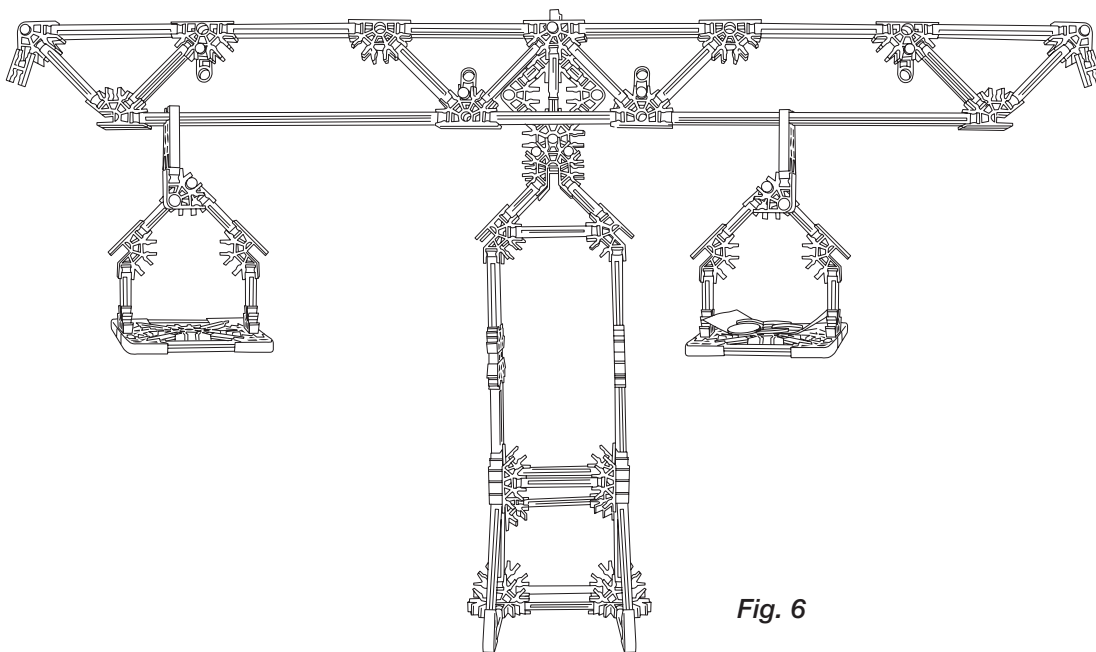
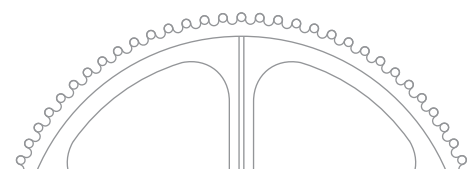

Fig. 6



Balance Worksheet

Observations

Part I: All Things Being Equal Table 1

Trial	Load distance (cm)	Effort distance (cm)	Mechanical Advantage: $\frac{\text{Effort distance}}{\text{Load distance}}$
1			
2			
3			

Part II(a): Unbalanced Forces

1. Distance from load pan to fulcrum: _____ cm.
2. Distance from effort pan to fulcrum: _____ cm.
3. Prediction: _____ pennies will return balance to the system.
4. How many pennies were actually used to balance the load force of 4 pennies? _____
5. Calculate the mechanical advantage of this system in the space below.
Show all work in your Journal.

Part II(b): Unbalanced Forces

1. Effort distance: _____ cm.
2. Load distance: _____ cm.
3. Prediction: _____ pennies will return balance to the system.
4. How many pennies were actually used to balance the load force of 4 pennies? _____
5. Calculate the mechanical advantage of this system in the space below.
Show all work in your Journal.

Balance Worksheet**page 2****Conclusion**

- **Challenge**

Each penny minted after 1982 has a mass equal to 2.5 grams. Design a first class lever system to balance the greatest load (number of pennies). Your design must stay within the following guidelines:

- Your system *cannot* include adding pennies to increase effort force.
- Both effort and load pans must be able to swing freely without contacting anything else.

- Draw your design in the space below.

Make these measurements:

Effort distance: _____ cm.

Load distance: _____ cm.

Mechanical advantage: _____

Total mass of load: _____

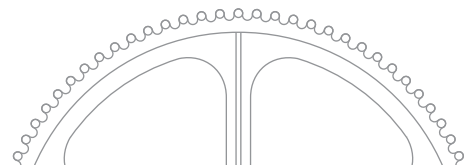

Tow Truck



Objectives

- To observe a handle acting as a wheel turning an axle.
- To collect data for a wheel and axle system that models a common machine.
- To determine mathematically the effort force needed to lift a load.

Materials

- K'NEX Tow Truck model

The following items are not included in the set:

- Spring scale
- Fishing sinkers or other weights

What's the Story?

A **wheel and axle** is a simple machine that transfers energy in a single motion. A wheel and axle is made up of two wheels of different size that turn together. An effort force applied to one wheel is transferred to the other wheel. A **winch** is a wheel and axle made up of two long, thin wheels called cylinders. The handle, or crank, traces out one cylinder. The shaft is the other cylinder. The mechanical advantage of a wheel and axle is calculated using the formula shown below.

$$MA = \frac{\text{effort radius}}{\text{load radius}}$$

Wheel provides effort

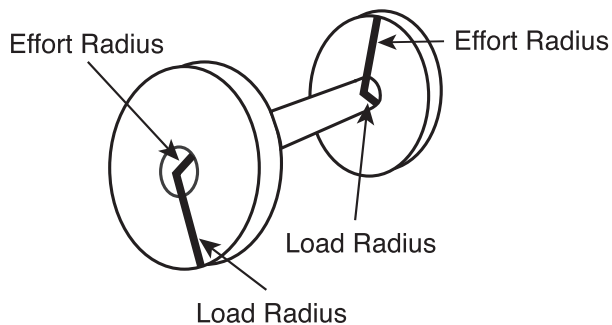

Axle provides effort

A rope or chain attached to the shaft is used to move a load. How can the mechanical advantage of a winch be used to calculate the size of the effort force needed to move a load? Do the following activity to find out.

Getting Started

1. Using the building instructions, build the K'NEX Tow Truck model.
2. Tie the weights to the hook on the tow truck line.
3. While holding the towline, roll the tow truck to the edge of the desk. Allow the weights to drop to the floor.
4. Use the crank to wind the towline and retrieve the weights.



What To Do

1. Attach a spring scale to the weights and lift the weights to the height of the pulley on the tow truck. Record the load force on the Tow Truck Worksheet.
2. Measure the radius of the wheel to which the effort is applied. The radius of the wheel is the distance from the center of the shaft (red Rod) to the center of the handle's shaft (blue Rod). Record this measurement - the effort radius of the wheel - on the Tow Truck Worksheet.
3. Measure the load radius of the axle. To do this, measure the diameter of the shaft. Calculate the radius by dividing the diameter by 2. Record the load radius of the shaft axle on the Tow Truck Worksheet.
4. To calculate the mechanical advantage (MA) of your winch, divide the effort radius by the load radius. Record the MA on the Tow Truck Worksheet.
5. Complete the questions on your worksheet.

notes

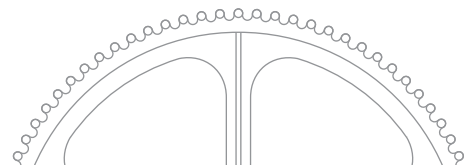

Tow Truck Worksheet

Observations

Weights

Load force _____ N.

Winch

Effort radius (handle) _____ cm.

Load radius (shaft) _____ cm.

MA of winch _____

Think About

1. For any machine, mechanical advantage is equal to load force divided by effort force.

$$MA = \frac{\text{load force}}{\text{effort force}}$$

Using load force and mechanical advantage shown above, re-arrange the above equation and calculate your effort force.

2. How would increasing the length of the handle affect the amount of effort force needed to raise the weights?



Tow Truck Worksheet

page 2

3. You are to design a winch to pick up a load. A person turning the handle, rather than a motor, will operate your winch. List three pieces of information that you will need to know to help you design the winch. You may write these as questions.

Challenge

A treasure chest weighing 300 N is found. You can exert a force of 30 N. Design a winch to raise the treasure chest. You will power the winch. Show all work in the space provided below.

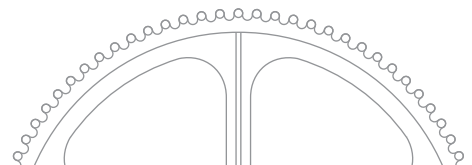

Block and Tackle

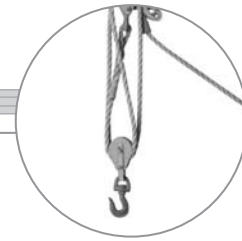

Objectives

- To explore the mechanical advantage of a block and tackle system.
- To measure experimentally work input and work output of a block and tackle system.
- To compare work input with work output in a block and tackle system.

Materials

- K'NEX Block and Tackle model

The following items are not included in the set:

- 2 fasteners or twist ties
- Spring scale
- 100 gram weight
- Ruler
- Calculator

What's the Story?

You have already discovered that some machines make doing a job easier by multiplying the force that you put into a machine. Other machines have the input force move through a greater distance, thereby allowing it to be small. Still others change the direction that a load moves. A machine multiplies your input force if it has a **mechanical advantage** greater than 1. Machines such as hammers and fishing rods, on the other hand, have mechanical advantages less than 1. These machines function to increase either speed or distance. In each case, work went into the system to get work out of the system. You can think of machines as energy converters that redirect your work input into work output. The energy you use to apply a downward force through

a distance, for example, is translated into a force used to raise a load through a distance. Work that goes into, or is produced by, a machine is measured in units called **joules**.

$$1 \text{ Joule} = 1 \text{ Newton} \times 1 \text{ meter}$$

(work = force x distance)

A block and tackle system uses several fixed and movable pulleys to multiply input force. In other words, block and tackle systems offer a very large mechanical advantage. Does that mean that you get more work out of the system than you actually put into it? Do the following investigations to find out.

What To Do

Part I: Work Output

1. Using the building instructions, build the K'NEX Block and Tackle model up to, and including, Step 7. Do not string the pulley system yet. The movable pulley tray should not be connected to the block and tackle frame at this point.
2. Place a textbook or notebook on the back of the block and tackle model to hold the frame firmly in place before beginning.
3. Place 100 grams of weight on the movable pulley tray. Attach the spring scale to the tray containing the weight.



Lift the tray 15 cm above the surface of the table. (See Fig. 1) Record the load force exerted by the weighted tray in Table 1 on the Block and Tackle Worksheet. Distance has been recorded for you.

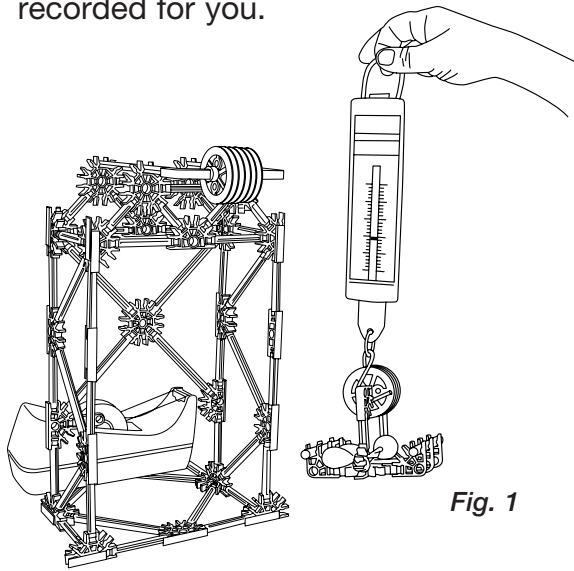

Fig. 1

Multiply the force of the weighted tray by the distance that the tray moved. Record your calculation in Table 1. This is the amount of **work** done by the machine (**work output**).

What To Do

Part II: Work Input

1. Loop the pulley rope over one fixed pulley, under one movable pulley on the tray, and over a second fixed pulley on the frame. (See Fig 2)
2. Attach the spring scale to the pulley string at the point where the string leaves the pulley wheel. Suggestion: tie the string to a purple Connector and hook the spring scale through the hole in the top of the Connector. Using the

spring scale, pull the pulley string to raise the tray 15 cm. Record the force shown on the spring scale in Table 2.

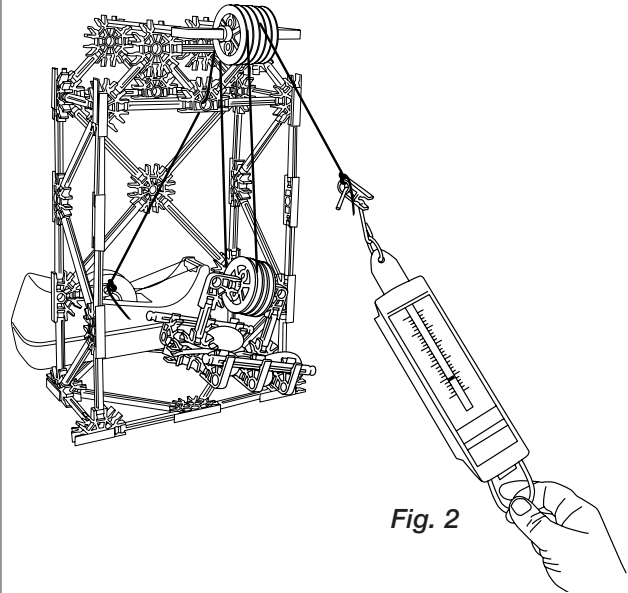

Fig. 2

3. Repeat Step 2 above, but this time tie a fastener, or twist tie, to the point where the string leaves the pulley. (See Fig. 3)

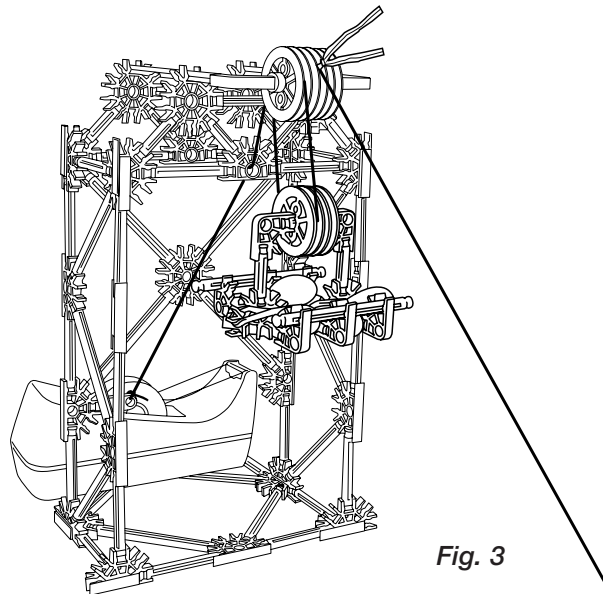

Fig. 3



4. Measure the distance between the fastener and the spring scale tie-on (the purple Connector you added in Step 2 above). Record this distance in Table 2.

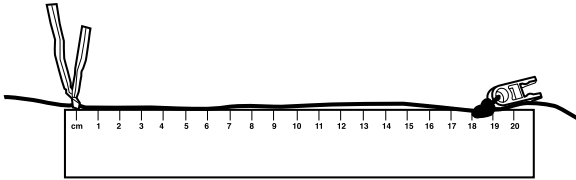

Fig. 4

5. Multiply force (Step 2) times distance (Step 4). Record your work calculation in Table 2. This is the amount of work that you put into the machine (**work input**).

6. Re-string your model so that all 3 fixed pulleys and both movable pulleys are used. (See Fig. 5)

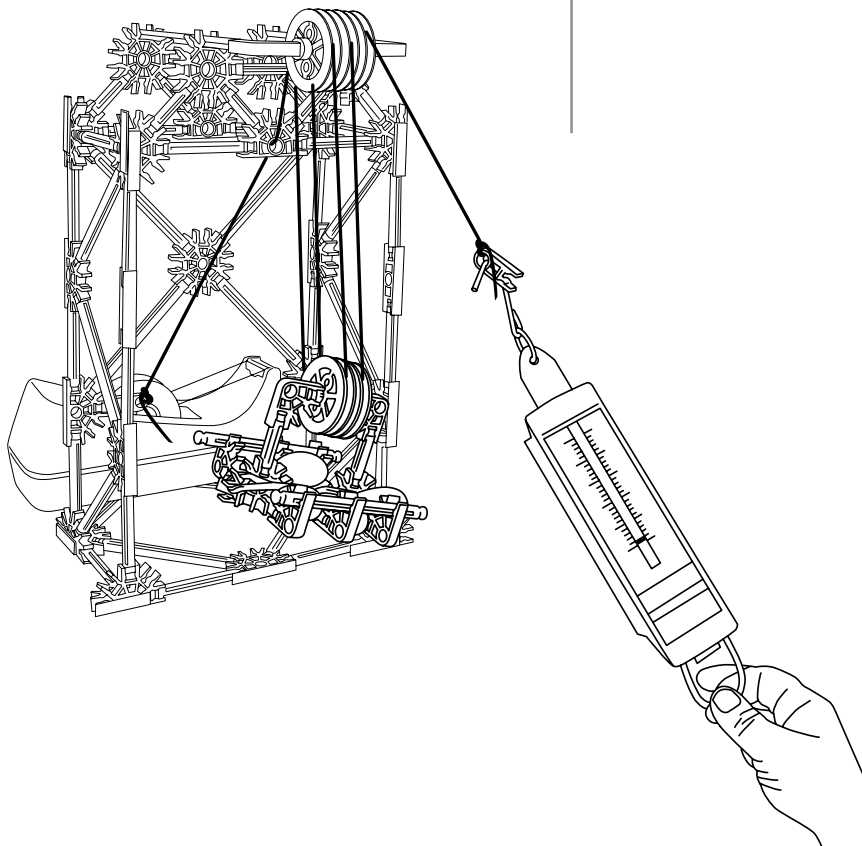

Fig. 5

7. Repeat Steps 2-6, recording force, distance, and work calculations in Table 2.

8. Complete the questions on your worksheet.



Block and Tackle Worksheet

Observations

Table 1: Work Output

	Load force (N)	Load distance (m)	Work (J) = Force X Distance
Weighted tray		0.15	

Table 2: Work Input

	Effort force (N)	Effort distance (m)	Work (J) = Force X Distance
Weighted tray and 1 movable pulley			
Weighted tray and 2 movable pulleys			

Think About

1. The load was raised to a height of 15 cm three times. How does the effort force compare to the load force each time the load was raised?

2. What effect did adding a second movable pulley have on the amount effort force needed to raise the tray 15 cm?

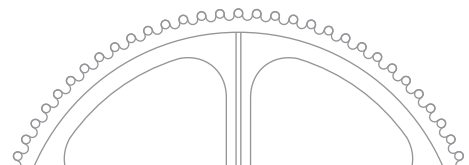

Block and Tackle Worksheet**page 2**

3. Was there trade-off, (gain versus loss,) for adding a second movable pulley? If so, what was exchanged for what?

4. How did work input compare with work output when one and two movable pulleys were used?

Challenge

Draw a block and tackle of your own design. Label the effort force and the load force. Describe the relationship between work input and work output for your block and tackle system.

Elevator

Objectives

- To observe the mechanical advantage of a fixed pulley system.
- To compare a fixed pulley system with a movable pulley system.

Materials

- K'NEX Elevator model

The following items are not included in the set:

- 2 paper clips (standard size)
- Spring scale (5-10 Newtons)
- Masking tape or dot stickers

What's the Story?

If your teacher asks you to raise the flag outside the school, how would you do it? Climb the pole? Use a ladder? Both these methods are difficult and dangerous. The flagpole offers a safer option: a pulley. A pulley is a grooved wheel with a rope or chain that runs around the groove. Pulleys can be either fixed or movable. **Fixed pulleys**, like those attached to the top of a flagpole, do not move. **Movable pulleys** are pulleys attached to objects being moved. They move as the object is moved. Both types of pulleys are used to lift heavy loads. Which type of pulley manages this task best? Do the activity below to find out.

What To Do

1. Build the K'NEX Elevator model. Before installing the cars in the elevator, weigh each with the spring scale.

2. On masking tape, or a small sticker, label the car attached to the fixed pulley, "A" and the car attached to the movable pulley system, "B".

3. Open both paper clips, forming each into an "S". Slip one end of one paper clip through the single fixed pulley rope at the point where it leaves the pulley wheel. Slip one end of the other paper clip through the other pulley rope at the same height.

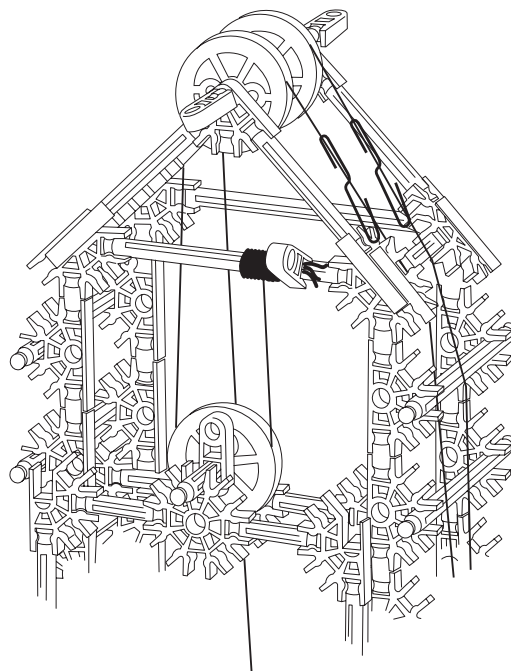
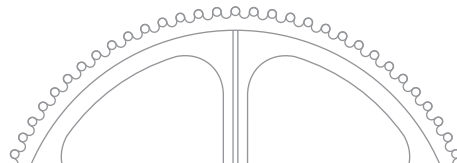

Fig. 1

4. Put a sticker on the yellow Rod that is approximately 22 cm above the bottom of the elevator car. (This should be the 3rd Rod down from the top.) Place your sticker on the same side of the model as the paper clips.



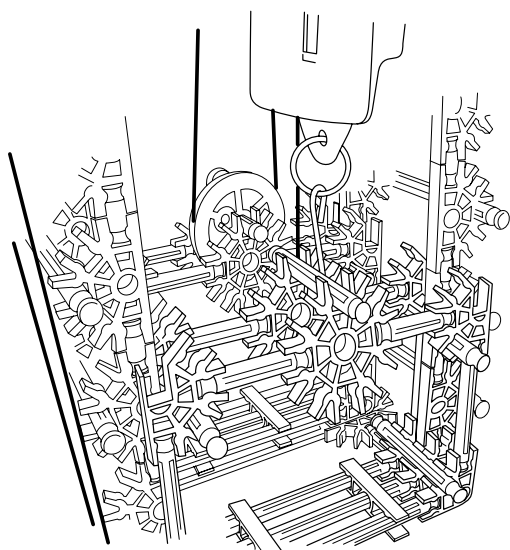

Fig. 2

5. Hook the spring scale under the center beam of Car A. (See Fig. 2) Using the spring scale, lift the elevator car 22 cm, so that the bottom of the car is level with the Rod you identified with a sticker. Record your observations in Table 1 on the Elevator Worksheet.

6. Hook the spring scale to the paper clip that you attached to the pulley rope of Car A. Pull the spring scale toward yourself, raising Car A to the same height as you lifted it in Step 5. (See Fig. 3) You will need to take 2 measurements:

- (i) The effort force needed to raise the elevator car. (This is the reading on spring scale.)
- (ii) The distance the rope has been pulled to raise the car. (Measure from the point at which the rope leaves the pulley wheel, to the point where the paper clip is attached to the rope.)

Record your observations in Table 1.

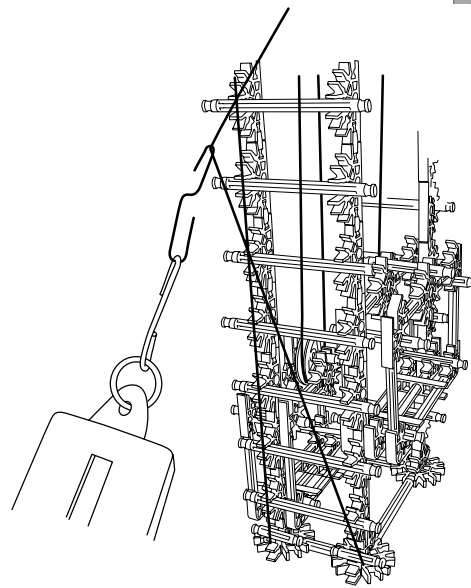

Fig. 3

7. Hook the spring scale under the center beam of Car B. Lift the elevator car 22 cm using the spring scale. Record your observations in Table 1.

8. Hook the spring scale to the paper clip that you attached to the pulley rope of Car B. Pull the spring scale toward yourself, raising Car B 22 cm again. You will need to take 2 measurements:

- (i) The effort force needed to raise the elevator car. (This is the reading on spring scale.)
 - (ii) The distance the rope has been pulled to raise the car. (Measure from the point at which the rope leaves the pulley wheel, to the point where the paper clip is attached to the rope.)
- Record your observations in Table 1.

9. Complete the questions on your worksheet.

Elevator Worksheet

Observations

Table 1

Elevator Car	Load Force (Weight of Car A) (N)	Effort Force (Force exerted to raise car using pulley) (N)	Distance rope was pulled to raise the car 22cm (cm)
A			
B			

Think About

1. How does the effort force used to lift Car A, using the pulley, compare with the force needed to lift the car directly with the spring scale?
2. How does the distance that your effort force moved compare with the distance that Car A moved?
3. How does the effort force used to lift Car B, using the pulley system, compare with the weight of car B?
4. You raised both Car A and Car B to the same height above the tabletop. What can you conclude about the relationship between effort force and effort distance when a **movable** pulley system is used?

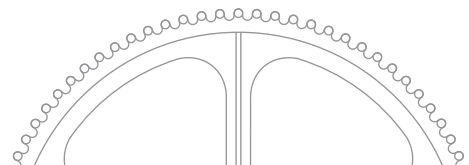

Elevator Worksheet

page 2

5. The mechanical advantage of a pulley system can be determined from the effort and load forces, using the formula shown below.

$$\mathbf{MA} = \frac{\text{load force}}{\text{effort force}}$$

Using your observations and your data, calculate the mechanical advantage of the single fixed pulley and the mechanical advantage of the single movable pulley systems.

Challenge

Which pulley system is most likely present in a real elevator system?
Explain your reasoning.



Screwdriver



Objectives

- To determine experimentally the mechanical advantage of a wheel and axle system.
- To determine mathematically the mechanical advantage of a wheel and axle system.

Materials

- K'NEX Screwdriver model

The following items are not included in the set:

- Tape
- String or twine
- 2 – fishing sinkers or other objects to be used as weights
- Ruler

What's the Story?

If you have ever turned a doorknob, or sharpened a pencil, or pedaled a bike, you are already familiar with wheel and axle machines. Simple machines transfer energy in a single motion. A wheel and axle is a simple machine made up of two wheels, of different sizes, that turn together. Although it does not look like it, an everyday screwdriver is actually an example of a wheel and axle simple machine. An input force is applied to the **wheel**, or handle, of the screwdriver. The wheel transfers the input force to the **axle** - the screwdriver shaft. The mechanical advantage (MA) of a wheel and axle system can be calculated using the formula shown below.

$$MA = \frac{\text{Distance moved by wheel (handle)}}{\text{Distance moved by axle (shaft)}}$$

How do differences in the size of the wheel and the size of the axle affect mechanical advantage? Do the following activity to find out.

What To Do

1. Build the K'NEX Screwdriver model.
2. Cut two 50 cm lengths of string. Tape one end of one string to the handle of the screwdriver. Tape one end of the other string to the axle of the screwdriver. Tie one weight to the end of each string. (See Fig. 1)

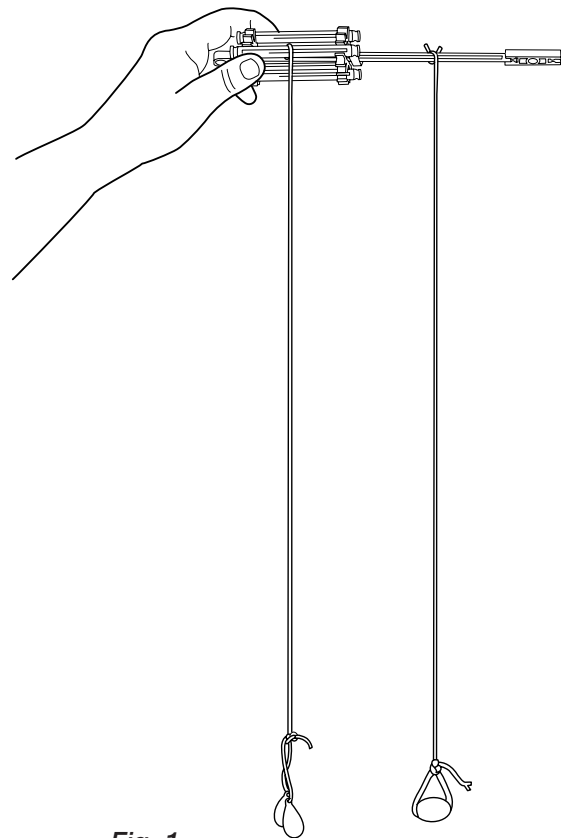
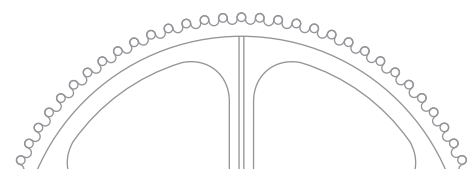

Fig. 1



3. Hold the screwdriver so that the weights hang straight down. Measure the length of each string from the handle to the end of the string. Record these “0 Turns” measurements in Table 1, Screwdriver Worksheet.

4. Turn the screwdriver so that the string wraps completely around the handle once.

5. Measure the length of each string. Subtract these measurements from the previous measurements to determine how much string was wrapped around the handle and the shaft. Record your measurements for 1 turn.

6. Turn the screwdriver one more full turn. Make sure that the strings do not overlap. Measure each string, complete the subtractions described above, and record the measurements for 2 turns in Table 1.

7. Turn the screwdriver two more times. Record your measurements for 3 and 4 turns in Table 1.

8. Complete the questions on the Screwdriver Worksheet.

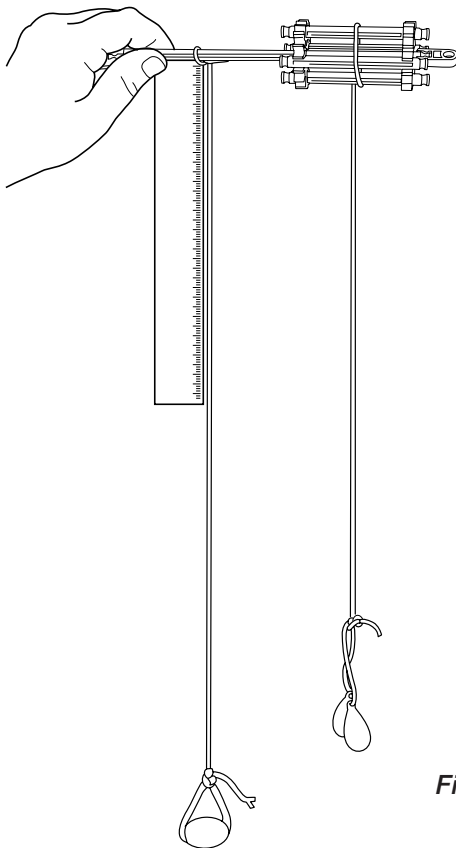

Fig. 2

Screwdriver Worksheet

Observations

1. Which weight rose fastest when the screwdriver was rotated?

Table 1

Number of Turns	String Length (cm)	
	Wheel	Axle
0		
1		
2		
3		
4		

Think About

1. The distance each weight moves equals the distance around the wheel to which it is tied. What is the distance moved by each weight when the screwdriver was turned one full turn?

Distance around wheel (handle) _____ cm.

Distance around axle (shaft) _____ cm.

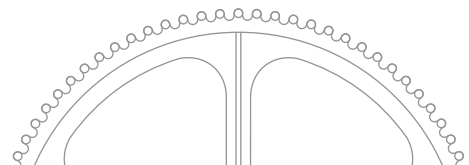

Screwdriver Worksheet

page 2

2. Calculate the mechanical advantage of your screwdriver using the formula shown below.

$$\mathbf{MA} = \frac{\text{Distance moved by wheel (handle)}}{\text{Distance moved by axle (shaft)}}$$

3. If you inserted a screw into a wall using your K'NEX screwdriver, how many times farther must the handle travel than the shaft?

4. What is gained when using a screwdriver? Use evidence from your investigation to support your answer.

5. Like all other simple machines, there is a trade-off when using a wheel and axle machine. Based on your calculation in Question 2 and your understanding of work, what is the trade-off when using a screwdriver? Remember, Work = Force X Distance.



Screwdriver Worksheet

page 3

6. The actual mechanical advantage of your screwdriver can be calculated directly from the machine using the formula shown below.

$$\text{MA} = \frac{\text{radius of wheel}}{\text{radius of axle}}$$

Measure and calculate the mechanical advantage of your K'NEX screwdriver using the formula shown above. Show all work in the space below.

Challenge

(a) You calculated the mechanical advantage of your screwdriver in Question 2 and then again in Question 6. Is the mechanical advantage calculated in Question 2 the same as the mechanical advantage calculated in Question 6?

(b) Name three (3) sources of experimental error that could explain your answer to (a).

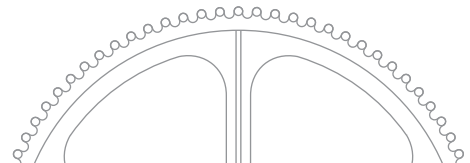

Paddlewheel Boat



Objectives

- To observe the effect on mechanical advantage when effort force is applied to the small wheel (axle) of a wheel and axle machine.

Materials

- K'NEX Paddlewheel Boat model

The following items are not included in the set:

- Meterstick
- Masking tape
- Spring scale (5-10 Newtons)
- Graph Paper

What's the Story?

Paddlewheel boats were an important form of transportation in the mid-1800s. At that time, steam-powered engines provided the work input used to propel the boat. Paddlewheel boats move using a wheel and axle system. A wheel and axle system is made up of two wheels that are rigidly attached together.

The wheel and axle system can be set up in two different ways:

#1. The effort force is applied to the rim of the larger wheel and the smaller wheel, or axle, turns with much greater force. To compute the mechanical advantage for this arrangement of a wheel and axle system, use the following formula:

$$MA = \frac{\text{Radius of the larger wheel}}{\text{Radius of the axle}}$$

Since in this arrangement the wheel is much larger than the axle, the mechanical advantage is very large and a great deal of force is transferred to the axle. In this arrangement the effort force is applied over a large distance (the circumference of the wheel), but the load force is applied over the small circumference of the axle. A rope attached to the axle would wrap around the axle very slowly but with great force. This explains why it takes a long time to raise a bucket of water with a wheel and axle crank, but the job can be completed with a relatively small amount of force.

#2. The effort force is applied to the rim of the axle and the rim of the larger wheel turns with greater speed. To compute the mechanical advantage for this arrangement of the wheel and axle system, use the following formula:

$$MA = \frac{\text{Radius of the axle}}{\text{Radius of the larger wheel}}$$

Since the axle is much smaller than the wheel in this arrangement, the mechanical advantage is much less than 1. This means that a small amount of force is transferred to the rim of the wheel. In this arrangement the effort force is applied over a small distance (the circumference of the axle), but the load force is applied over the large circumference of the wheel.





A rope attached to the wheel would wrap around the wheel very quickly but with less force. Much force, for example, must be applied to the axle of your family car so that its wheels turn fast enough and with enough force to move it.

In the paddlewheel boat model, an effort force is applied to a small wheel - the axle. This then turns the paddlewheels. What effect does applying the effort force to the smaller wheel have on the mechanical advantage of the machine? Do the following activity to find out.

Getting Started

1. Build the K'NEX Paddlewheel Boat model.
2. Loop one end of the rubber band over the purple Connector in the center of the axle as shown in Step 11 on Page 26 of the Building Instructions.

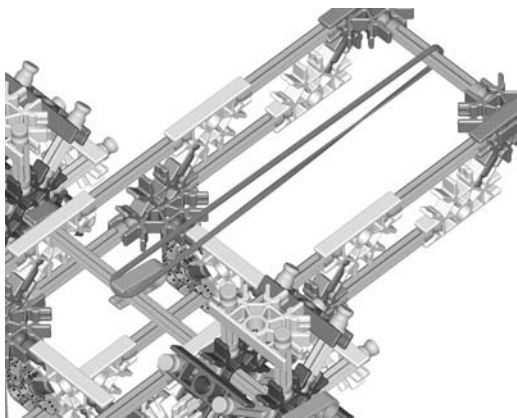

3. Turn the paddlewheels toward you so that the rubber band completely winds around the axle once. Release the paddlewheel and observe what happens. Describe what you observe in Table 1, Paddlewheel Boat Worksheet.

4. Repeat Steps 1 and 2 several times, increasing the number of times the rubber band wraps around the axle with each trial. (Caution: Do not break the rubber band. When the axle becomes difficult to turn, STOP!) What do you observe? Record your answer in Table 1.

What To Do

1. Compute the mechanical advantage of your wheel and axle system. Enter this value at **each** location in Table 2 of the Paddlewheel Boat Worksheet, as the mechanical advantage of the system will remain constant during this experiment.

Remember, $MA = \text{radius of axle} / \text{radius of wheel}$.

2. Place one turn of force into your wheel and axle system as you did in the 'Getting Started' section above.

3. Have someone hold the model and keep the wheel from unwinding, hook the spring scale to the end of one of the paddlewheel spokes - either on the orange Connector or the yellow Connector that connects the spokes of each wheel - to measure

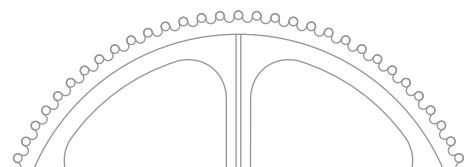

Paddlewheel Boat Worksheet

Observations

Table 1

Turns	Describe the motion of the Paddle Wheel
0	Stationary
1	FAST / SLOW (Circle One)
2	FASTER / SLOWER
3	FASTER / SLOWER
4	FASTER / SLOWER
5	FASTER / SLOWER

Enter the value you computed for the mechanical advantage of the system in the appropriate column of Table 2. The mechanical advantage **remains the same** throughout your trials, so you can enter the same value in each row of the column. Place your experimental results in the column entitled, "Spring Scale Reading (N) (Convert grams if necessary) LOAD FORCE". To calculate the Effort Force needed to produce that experimentally determined Load Force, use the following formula:

$$\text{Effort Force} = \frac{\text{Load Force}}{\text{Mechanical Advantage}}$$

(NOTE: If your spring scale is calibrated in grams, multiply the reading on the scale by .01 to find a close approximation to the number of Newtons the reading represents.)

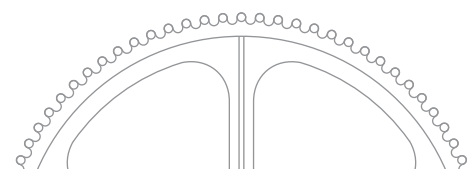

Paddlewheel Boat Worksheet

page 2

Table 2

Number of turns of rubber band	Spring scale reading (N) (Convert grams if necessary) LOAD FORCE	Mechanical Advantage of the system	Calculated EFFORT FORCE to produce that Load Force
1			
2			
3			
4			

Think About

1. What was the purpose of the rubber band?

2. Which turned a greater distance, the distance around the ends of the paddlewheels or the distance around the surface of the axle? Use your understanding of a wheel and axle system to support your answer.

3. Like all other simple machines, you cannot get more work out of a machine than you put into it. If $Work = Force \times Distance$, then what is gained by using a wheel and axle system in which a small axle turns a large wheel? Use your observations and your understanding of mechanical advantage to support your answer.

Paddlewheel Boat Worksheet

page 3

4. Why was the Effort Force you calculated for each trial of your experiment so much larger than the Load Force that was transferred to the rim of the paddlewheel?

5. Plot the data from Table 2 on graph paper provided by your teacher. Plot Effort Force (Vertical Axis) versus NUMBER of turns of the rubber band. Make sure that you label your axes and include units.

6. What information does your graph provide?

Challenge

1. List and describe three design changes that you could make to your boat that would increase the speed or the distance that it travels. If time permits, test your design changes.

2. Using the K'NEX Paddlewheel Boat as a starting point, design a paddleboat that will float and move across the water under paddlewheel power. (Hint: You will have to design a system that will enable your boat to float, in addition to designing a technique that will cause your boat to move under paddlewheel power.)

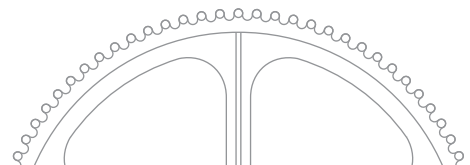

Dump Truck



Objectives

- To compare two classifications of inclined planes.
- To determine experimentally the function of a wedge.

Materials

- K'NEX Dump Truck model

The following items are not included in the set:

- Paperclips: 100-150
- Paper or foil

What's the Story?

The sloping surface of an inclined plane can be seen in a ramp, a screw, and a wedge. A **wedge** is an inclined plane with either one, or two, sloping surfaces. The head of an ax, and the end of a straight-edge, or blade-type, screwdriver are examples of wedges. Both wedges and ramps are simple inclined planes. They are classified, however, as different types of inclined planes.

What makes them different from each other? Do the following activity to find out.

What To Do

1. Build the K'NEX Dump Truck model.
2. Line the box of the dump truck with paper or foil to prevent your paperclips from falling out.

3. Fill the box of the truck with paperclips.

4. Slowly raise the front of the box, dumping the paperclips out through the gate.

5. Repeat Steps 3 and 4. Answer Question 1 on the Dump Truck Worksheet.

6. Collect all the paperclips together to form a large pile and position it in front of the dump truck.

7. Roll the truck forward slowly and use the **plow** on the front of the truck to push through the pile of paperclips.

8. Repeat Steps 6 and 7. Observe the relationship between the objects in this system. Answer Question 2 on the worksheet.

9. Complete the remaining questions and activities on the worksheet.

Dump Truck Worksheet

Think About

1. Raising the box changed the bed of the box into a ramp. How would you describe the motion of the paperclips relative to the box of the dump truck? Which changes position more, the bed of the box or the paperclips?

2. The plow blade acts like a wedge. How would you describe the motion of the paperclips relative to the plow blade? Which changes position more, the plow blade or the paperclips?

3. Why are ramps and wedges classified differently? Use evidence from this activity to explain your reasoning.

4. Your plow blade is an example of an inclined plane that has one sloping surface. Plows used in agriculture often use two or more sloping surfaces. Why is this type of wedge more practical than the one used on your plow?

5. Would your front teeth be classified as ramps or wedges? Explain your answer.

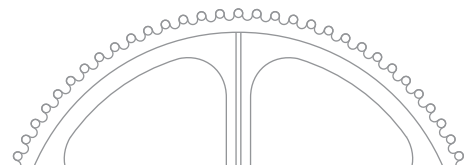

Inclined Plane



Objectives

- To calculate the mechanical advantage of an inclined plane.
- To determine experimentally the mechanical advantage of an inclined plane.
- To compare theoretical with actual mechanical advantage.

Materials

- K'NEX Archimedes' Screw model

The following items are not included in the set:

- Spring scale (5-10 Newtons)
- Mass or paper cup containing marbles or pennies

What's the Story?

Some simple machines do not look like machines at all. Ramps are sloping surfaces that help you move from one elevation to another. A ramp is an example of an inclined plane. Calculating the mechanical advantage of an inclined plane is similar to calculating the mechanical advantage of a lever. Both calculations involve distances. In the case of inclined planes, the distance the effort moves equals the length of the ramp, from start to finish. The load distance equals the height that the ramp raises the load. In a frictionless system, the **ideal mechanical advantage** of an inclined plane is calculated using the equation shown below.

$$\text{IMA} = \frac{\text{effort distance}}{\text{load distance}} = \frac{\text{length}}{\text{height}}$$

However, since friction is present in almost all systems, the **actual mechanical advantage** of a machine is often less than the ideal mechanical advantage. How does an inclined plane make work easier? Do the following activity to find out.

Getting Started

Build the K'NEX Archimedes' Screw model up to, and including, Step 4 of the Building Instructions.

(NOTE: If you have already built the entire model, carefully separate the screw from the inclined plane and set it to one side as you will not need it for this inquiry.)

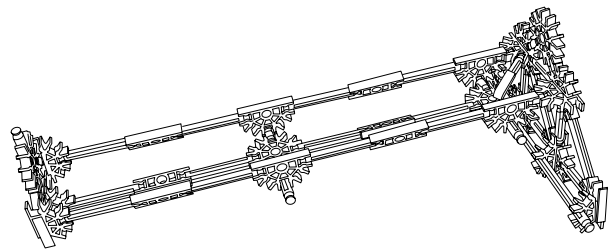

Fig. 1

What To Do

1. Measure the length of the ramp. Record the measurement on the Inclined Plane Worksheet.

2. Measure the height of the ramp from the tabletop to the top of the ramp. Record the measurement on the worksheet.
3. Calculate the ideal mechanical advantage of your inclined plane. Record the calculation on the worksheet.
4. Attach the spring scale to the mass. Lift the mass straight up from the tabletop until it is level with the top of the ramp. Record the load force on the worksheet. This spring scale measurement indicates the force needed to lift the mass without the aid of the ramp. (Load force.)

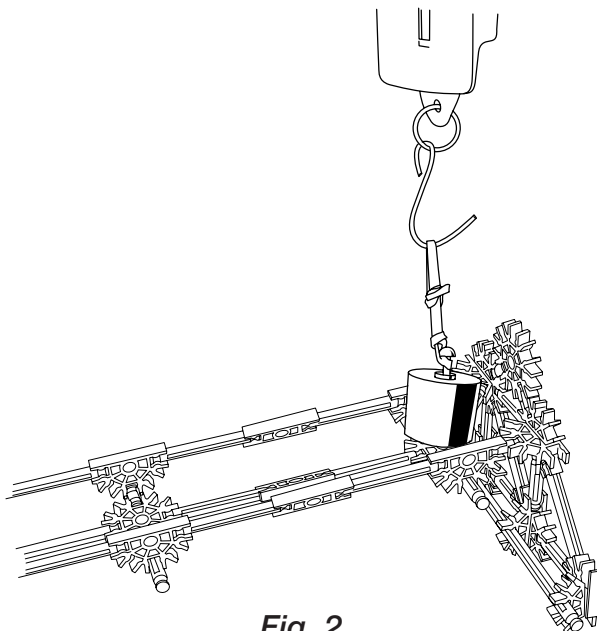

Fig. 2

5. Based on your calculation for mechanical advantage, **predict** the amount of force that you must exert to pull the mass up the ramp. Write your prediction on the worksheet.

6. Attach the spring scale to the mass. Place the mass at the base of the ramp. Pull the mass up the ramp. Record the force on the worksheet. Make your force reading when you are pulling on the mass and it is moving freely. Move the mass slowly and at a constant speed.

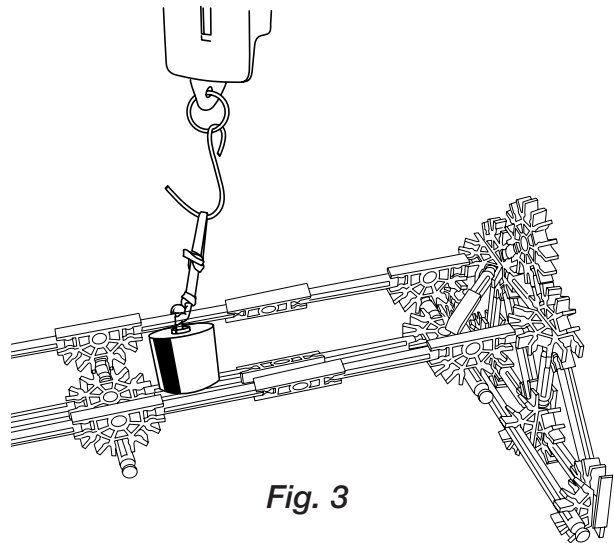
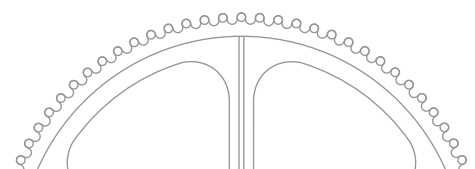

Fig. 3

7. Calculate the actual mechanical advantage using the formula shown below.

$$MA = \frac{\text{load force}}{\text{effort force}}$$

8. Complete the questions and activities on the Inclined Plane Worksheet.



Inclined Plane Worksheet

Observations

Length of ramp: _____ cm.

Height of ramp: _____ cm.

$$\text{Ideal MA} = \frac{\text{effort distance}}{\text{load distance}} = \frac{\text{length}}{\text{height}}$$

Ideal MA = _____

Load Force: _____ N.

Predictions:

Effort Force used to pull the weight to the top of ramp: _____ N.

$$\text{Actual MA} = \frac{\text{load force}}{\text{effort force}}$$

Actual MA = _____

Think About

1. Can you suggest at least 2 reasons for the difference in the two values for mechanical advantage?
2. How do inclined planes make work easier?
3. What is the trade-off when using an inclined plane?



Inclined Plane Worksheet

page 2

Challenge

1. How could you change your inclined plane so that its actual mechanical advantage is increased?
2. Test your design. Calculate the actual mechanical advantage of your redesigned plane. Record your observations in the space below.

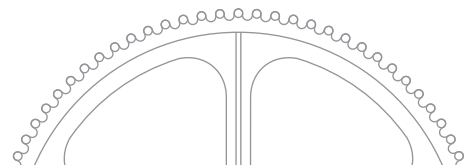

Archimedes' Screw



Objectives

- To explore the structure of a screw.
- To observe two functions of a screw.

Materials

- K'NEX Archimedes' Screw model

The following items are not included in the set:

- Ruler
- Length of string (40-45cm) - optional
- Ping pong ball
- Screw

What's the Story?

Inclined planes show up as ramps, wedges, and screws. In fact, screws have been around for over 2500 years. A **screw** is an inclined plane wrapped around a cylinder. Archimedes, a Greek mathematician and inventor, included a screw in a machine that he invented while visiting Egypt. The River Nile is the main source of water for that arid country. For part of the year the river flooded the farmlands on either side of its banks, but for most of the year its water level was well below them. Before Archimedes' invention, watering crops usually meant using buckets to raise water by hand from the River Nile and then emptying it into irrigation channels that led to the fields.

How did the Archimedes' Screw make watering crops in Egypt easier? Do the following activity to find out.

Getting Started

1. Build the K'NEX Archimedes' Screw model.
2. Turn the handle and observe the motion of the screw.

What To Do

1. Remove the Archimedes' Screw from the ramp. This is the part you attached in Step 10-11. (See Building Instructions.)
2. Measure the length of the **inclined plane**. This is the part of the model that you built in Step 8. (See Building Instructions.) Record the measurement on the Archimedes' Screw Worksheet. (Note: You may find it easier to use a piece of string to find the length of the inclined plane and then read off the length of the string on your ruler.)
3. Measure the length of the **cylinder** that the inclined plane was wrapped around. This is the part of the model you built in Steps 5-7. (See Building Instructions.) Record the measurement on the worksheet.
4. Re-attach the Archimedes' Screw to the ramp. (Step 9 in the Building Instructions.)
5. Place the ball on the ramp.

Archimedes' Screw Worksheet

Observations

Length of inclined plane: _____ cm.

Length of cylinder: _____ cm.

What happens when you turn the handle?

Think About

1. Describe the movement of force through the system.
2. Your Archimedes' Screw is used to do work. Which variable - force or distance - is multiplied when you use a screw? Explain your reasoning.
3. If you could not turn the machine faster, how could you increase the number of balls moved to the top of the ramp in 1 minute?
4. Using your observations and understanding of screws, describe how an Archimedes' Screw helped farmers in Egypt to water crops in elevated areas.
5. Can you think of other applications of Archimedes' type of screw? List them.
6. If you do not already have one, obtain a screw from your teacher. Explore how screws hold objects together. How are an Archimedes' Screw and a screw used as a fastener different?



Archimedes' Screw Worksheet

page 2

Challenge

The Archimedes' Screw is still used in Egypt today. Research Archimedes' Screw. In the space below, describe ways that you could change your Archimedes' Screw so that it functions as Archimedes intended. Draw a picture if it helps your description.

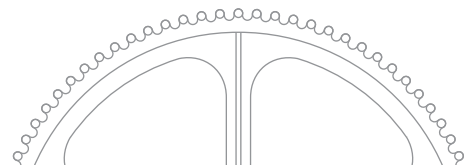

Conveyor Belt



Objectives

- To explore the structure of a conveyor belt system.
- To describe and explain the operation of a conveyor belt system.

Materials

- K'NEX Conveyor Belt model

The following items are not included in the set:

- Dot sticker or masking tape

What's the Story?

Imagine that your teacher asked you to design a machine that transfers energy and force from one location to another that is approximately 15 meters away. What would your machine look like? What parts would it include? You could use many spur gears meshed together. A **sprocket system**, however, might be a better option. A sprocket system is made up of two or more gears connected by either a belt or a chain. The gears and chain on a bicycle are an example of a common sprocket and chain system.

How do the parts of a conveyor belt system transfer energy and motion? Do the following activity to find out.

Getting Started

1. Build the K'NEX Conveyor Belt model.

2. Hold the frame of the conveyor belt firmly in place with one hand. Turn the crank of the conveyor belt and observe the direction of motion of each gear.

What To Do

1. Remove the crank from the conveyor belt. (This was the part added in Step 9 of the Building Instructions.)
2. Place a dot sticker or small piece of masking tape on, or close to, one tooth of the belt gear - this will be your reference point for the activities described below.
3. Turn the **belt gear** using your fingers until the gear completes one full turn. (See Fig. 1)

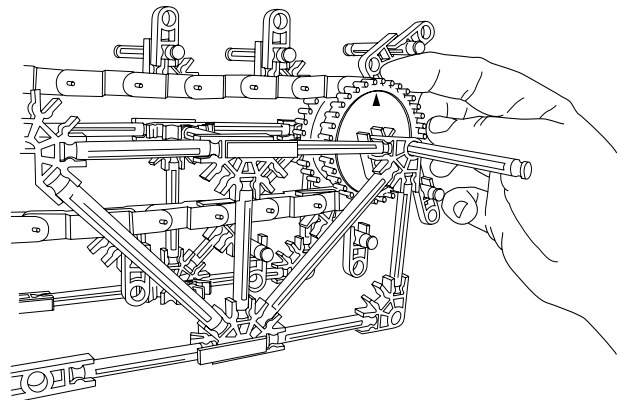

Fig.1

Conveyor Belt Worksheet

Observations

Table 1

	Number of Complete Rotations	Time (seconds)
Belt gear	20	
Shaft	20	
Crank	20	

Think About

1. Describe how force is transferred through the system.
2. You used three methods for turning the belt gear. Which method required the most Effort Force? How do you know?
3. How does the weight of the belt affect the amount of force needed to turn the crank?
4. Describe how the moving parts in your conveyor move as you turn the handle. Pay particular attention to the direction in which each part moves.
5. How is it possible for items on a conveyor belt to move in a straight line from place to place if all the parts move in a circular path?

Conveyor Belt Worksheet

page 2

6. Can you determine the mechanical advantage of the conveyor belt system? (Do not include any MA obtained from the handle.)

7. In your own words, describe why you think conveyor belts and chain drive systems are useful?

8. Large airports often use conveyor walkways to transport people over long, straight distances. Why are the conveyor walkways only found in straight sections and are not used to move passengers throughout the entire airport?

Challenge

1. A conveyor belt is a machine that changes the rotational motion of a wheel and axle into straight-line or linear motion. Predict how changing the size of the belt gear would affect the speed of the conveyor belt compared to the speed of the handle as it is turned.

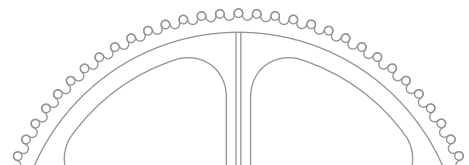

Conveyor Belt Worksheet

page 3

Challenge

2. Design and draw a conveyor belt system that will improve service at a restaurant. The system must be able to deliver hot foods to the servers' station and return dirty dishes to the kitchen. If you plan carefully, you should be able to complete this challenge using a single conveyor belt system.

Challenge

3. Using smaller gears, change the size of the belt gears. Record your observations in the space below.

Challenge

4. Why don't typical conveyor belts have different size gears? Build one to reinforce your answer.



Rack and Pinion

Objectives

- To determine experimentally the mechanical advantage of a rack and pinion gear system.
- To describe and explain the operation of a rack and pinion gear system.

Materials

- K'NEX Rack and Pinion model

The following items are not included in the set:

- Washable marker
- Dot stickers/masking tape
- Ruler

What's the Story?

A gear is a wheel that has teeth or cogs along its circumference. Many types of gear systems combine two or more gears, either meshed together directly, or connected by a chain. In a rack and pinion system, a single gear called a **pinion** meshes with a toothed bar called a **rack**. Gear systems offer a mechanical advantage when either force or speed is gained.

What advantage does a rack and pinion system provide? Complete the following activity to find out.

Getting Started

1. Build the K'NEX Rack and Pinion model.
2. While holding the frame firmly in place, rotate the handle of the rack and pinion. Observe what happens.

What To Do

1. Place a dot sticker or small piece of tape on the upper surface of one tooth of the pinion gear. (This reference mark will help you accurately rotate the gear through 180° in Step 4 below.)

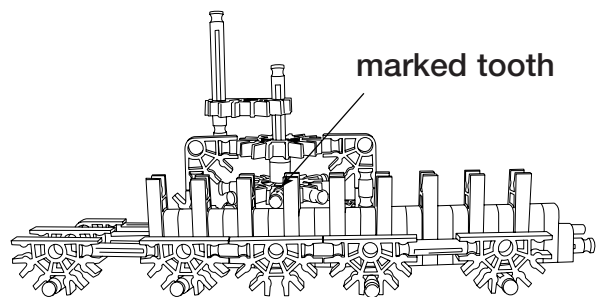
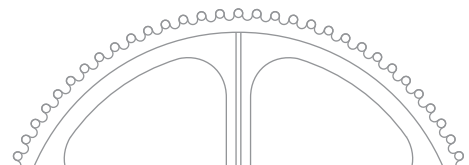
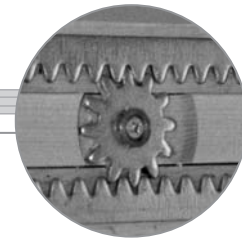

Fig. 1

2. Measure the diameter of the pinion gear. Record this measurement on the Rack and Pinion Worksheet.
3. Compute the circumference of the pinion (with gear teeth). Use the formula $C = \pi d$ or $C = 2 \pi r$.
4. Turn the handle of the rack and pinion system until it is in the starting position shown below. (Make sure that the gear tooth is right up against a orange Connector - probably the third from the left - so that, when the handle is turned, the gear tooth immediately starts to move the rack.)



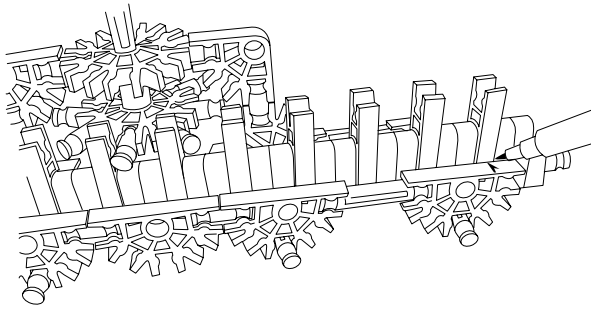

Fig. 2

5. Using a washable marker, identify the starting position of the first tooth in the rack. (See Fig. 2) Alternatively, use a small piece of masking tape to identify the start position.

6. Turn the handle so the pinion moves through one-half turn. Since there are eight teeth on the pinion gear, you will reach that position when the fourth gear tooth is in the same position as the gear tooth shown in Fig. 2. Using a washable marker (or masking tape), mark the ending position of the first tooth in the rack after this rotation. (See Fig. 3)

7. Using the pen marks (or masking tape markers) as a guide, measure how far the rack has moved during one-half turn of the pinion. Record this distance on the Rack and Pinion Worksheet.

8. Calculate the distance that **the teeth on the pinion** moved. Record your calculation on the worksheet.

9. Compute the mechanical advantage of the rack and pinion. State the formula you decided to use and your reasoning for using that formula.

10. Complete the questions and activities on the worksheet.

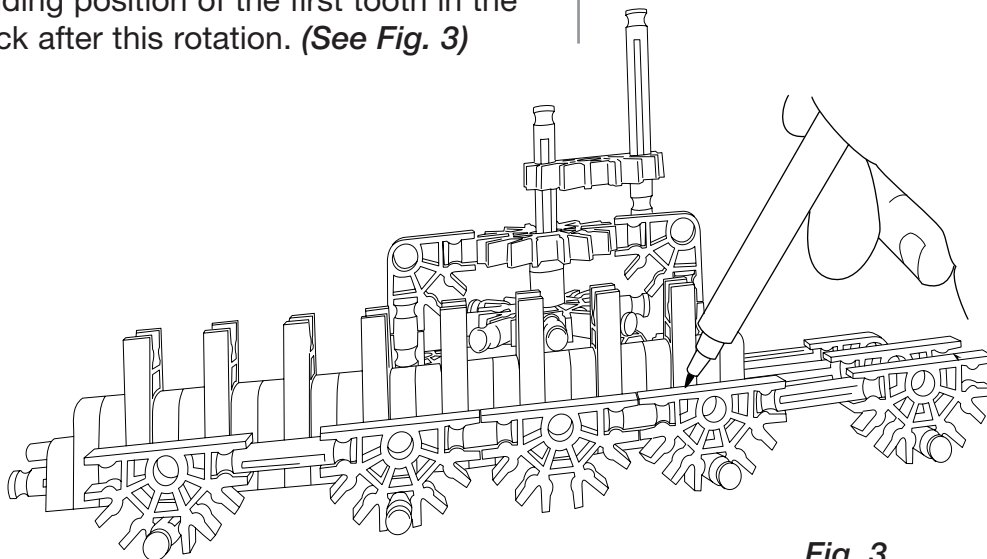

Fig. 3

Rack and Pinion Worksheet

Observations

Diameter of the pinion gear (d): _____ cm.

Circumference of the pinion gear: _____ cm.

Distance rack moved: _____ cm.

Calculate the distance the teeth of the pinion gear moved during one-half turn of the gear:

_____ cm.

Think About

1. Compare the distance the rack moved with the distance the teeth on the pinion moved. Write your answer in the space below.
2. Compute an actual mechanical advantage for the rack and pinion gear system. Why did you choose the method you did?
3. How does the motion of the rack compare with the motion of the pinion? (Hint: Think geometry.)
4. List all the steps of force transfer in the system.
5. How is a rack and pinion system useful?

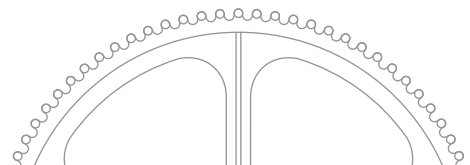

Rack and Pinion Worksheet

page 2

Challenge

1. Research 3 machines that use a rack and pinion gear system and the task that this gear system performs in each machine. In the space below, list these machines and the jobs they perform. For example, a rack and pinion gear system causes the windshield wipers on a car to move back and forth.

Challenge

2. Identify a simple task that could be performed using your K'NEX rack and pinion gear system. Describe how you would change your K'NEX rack and pinion system to accomplish the task.

Challenge

3. Test your design. Describe your observations in the space below.



Crank Fan



Objectives

- To determine experimentally the gear ratio of a model crank fan.
- To determine mathematically the gear ratio of a model crank fan.

Materials

- K'NEX Crank Fan model
- Dot sticker or masking tape (not included in the set)



What's the Story?

A gear is a wheel that has teeth, or notches, along its circumference. Two or more gears that interlock, or mesh together, form a **gear train**. In a simple gear train made up of two gears, you apply an effort force to the **driver gear**. The driver gear transmits the effort force to the driven gear. The gears in a gear train act like a series of levers used to multiply force, or speed, or change direction.

Gear ratio refers to the relative sizes of the driver and driven gears. You can determine gear ratio by comparing the number of revolutions

completed by the driver gear to the number of revolutions completed by the driven gear. You can also determine gear ratio by counting and comparing the number of teeth on each gear. The methods for determining gear ratio are shown below. Both give the same results.

Formula 1:

$$\text{gear ratio} = \frac{\text{number of revolutions of the driver gear}}{\text{number of revolutions of the driven gear}}$$

Formula 2:

$$\text{gear ratio} = \frac{\text{number of teeth on driven gear}}{\text{number of teeth on driver gear}}$$

Gear ratio and speed are two concepts that are often linked together. Remember, gears are used to multiply force, or speed, or change direction. A bicycle often has several different sized gears attached to the rear wheel. When combined with the gear that you pedal, you now have several different gear ratios that you can use to change the speed of your bike. A typical low speed gear ratio on a bike is 1:1.2. That means that when your pedal gear completes 10 revolutions, the gear on your rear wheel completes 12 revolutions.

The gears in the K'NEX Crank Fan model are arranged in a **spur gear system**. That means that the gears transmit force along the same geometric plane. In Version 3 of the

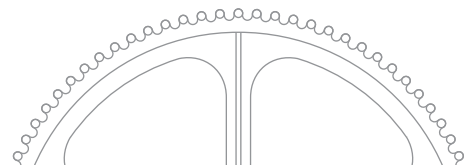

model, a large gear, attached to a crank, meshes with a smaller gear directly above it. The large gear is the driver gear that transmits force to the smaller gear above it.

What is the relationship between gear ratio and speed? Complete the following activity to find out.

Getting Started

1. Build **Version 3** of the Crank Fan model.
2. While holding the frame of the crank fan firmly with one hand, spin the fan blades of the crank fan. Spin the blades quickly, while applying force only to the fan blades.
3. While holding the frame of the crank fan firmly with one hand, turn the handle of the crank and observe the speed of the fan.
4. Turn the fan blades and the crank in opposite directions from those in Steps 2 and 3.

What To Do

1. Predict how many times the fan will revolve before the large gear completes one full revolution? Write your prediction on your Crank Fan Worksheet.
2. Arrange the model so that the orange Connectors of the crank and **one** of the fan blades are in a vertical position, at right angles to the tabletop.

3. Place a dot sticker or piece of masking tape on the vertical fan blade. Use this as your starting point for the following activities.

4. Slowly turn the crank until the “marked” **fan blade** completes one full revolution. Observe the position of the crank.

5. Continue to slowly turn the crank, counting the number of revolutions completed by the “marked” fan blade, until the crank returns to the start position. Record the number of revolutions completed by both the driver gear and the fan blade on the Crank Fan Worksheet.

6. Using Formula 1 and your data for complete revolutions, determine the gear ratio for the crank fan. Record your answer on the worksheet.

7. Count the number of teeth on the large driver gear. Record this number on the worksheet.

8. Count the number of teeth on the small driven gear. Record this number on the worksheet.

9. Using Formula 2 and your data for gear teeth count, determine the gear ratio for the crank fan. Record your answer on the worksheet.

10. Complete the questions on the worksheet.



Crank Fan Worksheet

Prediction

How many times will the fan revolve before the large gear completes one full revolution? Write your prediction in the space below.

Observations

Number of revolutions completed by the driver gear: _____

Number of revolutions completed by the driven gear attached to the fan: _____

Gear ratio: _____

Number of teeth on the driver gear: _____

Number of teeth on the driven gear: _____

Gear ratio: _____

Think About

1. How does the gear ratio calculated using Formula 1 compare with the gear ratio calculated using Formula 2?

2. **Version 3** of the **Crank Fan** represents a gear system that has a high gear ratio. That means that there is a large difference between the size of the driver gear and the size of the driven gear. How would you describe the speed of the crank relative to the speed that the fan is moving in this high gear system?

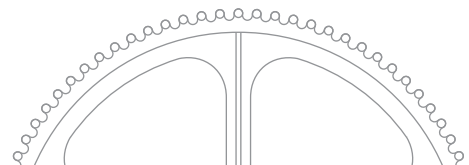

Crank Fan Worksheet

page 2

3. Examine the diagram for **Version 1** in your **Crank Fan** Building Instructions. What gear ratio is used in this version of fan construction? Explain the reason behind your answer.

4. Compare the direction in which the fan revolved with the direction in which the driver gear revolved. Explain what caused the direction of motions that you observed. NOTE: Avoid using the terms “clockwise” and “counterclockwise” to describe the motion of the fan because observers on opposite sides of the fan, using these terms, will describe the motion differently.

Challenge

1. What would happen if the small gear was used as the driver gear and the large gear was the driven gear? Write your prediction in the space below.



Crank Fan Worksheet

page 3

Challenge

2. Using the **Crank Fan** Building Instructions, build **Version 2** of the crank fan model. Turn the crank. Based on your observations and your data, write a conclusion that answers the question, "What is the relationship between gear ratio and speed?"

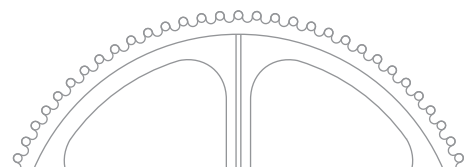

Carousel

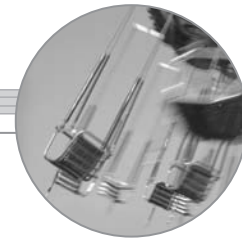

Objectives

- To determine the mechanical advantage of a crown gear system.
- To identify simple machines used to transfer input force.

Materials

- K'NEX Carousel model

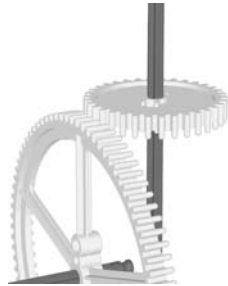

What's the Story?

A gear is a wheel that has teeth along its circumference. Two or more gears that interlock, or mesh together, form a **gear train**. In a simple gear train made up of two gears, you apply an effort force to the **driver gear**. The driver gear transmits the effort force to the **driven gear**. The gears in a gear train act like a series of levers and are used to multiply force, or speed, or change direction. The gears in the K'NEX Carousel are arranged in a **crown gear system**. In a crown gear system, one gear forms a 90-degree angle with another gear. That means that the input force goes through a 90-degree change in direction.

Why does your carousel use a crown gear system? What advantage does it provide? Complete the following activity to find out.

Getting Started

1. Build the K'NEX **Carousel** model.
2. While holding the frame of the carousel firmly with one hand, turn the handle of the crank and observe the motion of the carousel.
3. Using your fingers, rotate the carousel by turning the blue Rod on the peak of the carousel. Feel the amount of force that must be applied to spin the carousel.
4. Turn the crank of the carousel. Feel the amount of force that must be applied to spin the carousel.

What To Do

1. Count the number of teeth on the driver gear. Record your observation on the Carousel Worksheet.
2. Count the number of teeth on the driven gear. Record your observation on the worksheet.
3. Calculate the mechanical advantage of the crown gear system. Record your calculation on the worksheet. (Hint: $MA = \text{number of teeth on the driven gear} / \text{number of teeth on the driver gear}$)
4. Complete the questions on the worksheet.



Carousel Worksheet

Observations

Number of teeth on driver gear: _____

Number of teeth on the driven gear: _____

MA: _____

Think About

1. How did the crown gear system make work easier? Use evidence from your observations and your data to support your answer.
2. What is/are the trade-off(s) using this system?
3. List two simple machines that combine to form the mechanism used to move the carousel.
 - (i)
 - (ii)
4. Draw a carousel design that shows what the carousel would look like if it used a spur gear system. (Feel free to draw a top view or a side view of the carousel.)

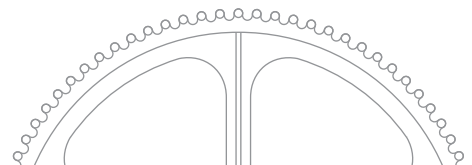

Carousel Worksheet

page 2

5. What is the advantage of using a crown gear system?



Challenge

Research and describe another machine that uses a crown gear system.

Transmission

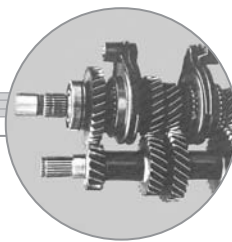

Objectives

- To calculate gear ratios in a two speed transmission system.
- To determine experimentally how changing gear ratio affects torque.

Materials

- K'NEX Transmission model
 - Page 51 of the Building Instructions
- The following items are not included in the set:**
- String (20-30 cm)
 - Weights (10 or 20 gram)

What's the Story?

Recall that gear ratio can be determined using either the ratio of revolutions or the ratio of teeth on two gears.

$$\text{gear ratio} = \frac{\text{number of revolutions of the driver gear}}{\text{number of revolutions of the driven gear}}$$

OR

$$\text{gear ratio} = \frac{\text{number of teeth on driven gear}}{\text{number of teeth on driver gear}}$$

Gear ratio and speed are two concepts that are often linked together. If gears are used to multiply speed, then the gear ratio should tell you something about how speed changes when different sized gears are used. A bicycle often has several different sized gears attached to the rear wheel. When combined with the gear that you pedal,

you now have several different gear ratios that you can use to change the speed of your bike. A typical low speed gear ratio on a bike is 1:1.2. That means that when the gear attached to your pedal completes 10 revolutions, the gear on your rear wheel, the driven gear, completes 12 revolutions. If it takes 1 minute for the driver gear to complete 10 revolutions, then the driver gear is turning at a rate of 10 revolutions per minute (**rpm**). As a result of gear ratio and the rate that the driver gear turns, the driven gear turns at a rate of 12 rpm.

The K'NEX transmission model has two sets of gears. Complete the following activity to find out how changing the gear ratio affects the operation of the transmission.

Getting Started

1. Build the K'NEX Transmission model.

(NOTE: The following directions assume that the fan blades are at the front of the model and the drive shaft extends out from the back of the model.)

2. Refer to the pictures in the **middle** of Page 51 of your Building Instructions. Lift the yellow Rod and place it in front of the orange Connectors. The gear shaft will

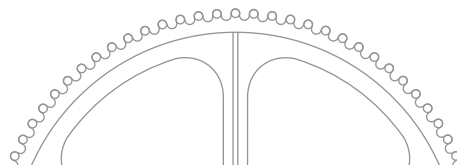

move all the way forward. Turn the drive shaft and observe what happens. Feel how much effort force is needed to turn the drive shaft. This is **first gear**.

3. Refer to the pictures at the **bottom** of Page 51 of your Building Instructions. Lift the yellow Rod and place it behind the orange Connectors. The gear shaft will move all the way to the rear of the transmission. Turn the drive shaft and observe what happens. Again, feel how much effort is needed to turn the drive shaft. This is **second gear**.

What To Do

1. Return the transmission model to first gear.
2. On the Transmission Worksheet, identify the data source that you will use to gather the information needed to calculate the gear ratio for your transmission.
3. On the Transmission Worksheet, identify the equation that you will use to calculate the gear ratio.
4. Calculate the gear ratio of the transmission when it is in first gear. Record the calculation in Table 1.
5. With the transmission in first gear, turn the drive shaft. Record your observations in Table 1.
6. Shift the transmission to second gear.

7. Calculate the gear ratio of the transmission when it is in second gear. Record the calculation in Table 1.

8. With the transmission in second gear, turn the drive shaft. Record your observations in Table 1.

9. Complete the questions and activities on the worksheet.



Transmission Worksheet

Methods

1. Which formula will you use to calculate gear ratio?

Table 1

	Gear Ratio	Observations
First gear		
Second gear		

Think About

1. First gear uses gears that are the same size as those of second gear. Why is the speed of the fan in first gear different from the speed of the fan in second gear?
2. The turning force that you applied to the drive shaft is called **torque**. Take your time to think carefully. Design an experiment to determine which gear system, first gear or second gear, transmits the most torque to the fan. Include diagrams if it adds to your explanation.

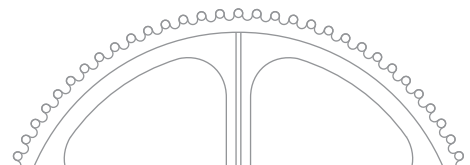

Transmission Worksheet

page 2

3. Based on your experiment, which gear transmits the most turning force (torque) to the fan?

4. What is the relationship between gear ratio, speed, and torque?
Explain your reasoning.



Teacher's Answer Sheet

Balance Worksheet

Observations

Part I: All things being Equal

Table 1: Distances recorded will vary. MA = 1 in each trial.

Part II(a): Unbalanced Forces

Answers will vary. Possible answers:

1. 24 cm
2. 12 cm
3. Prediction.
4. About 8 pennies.
5. Mechanical advantage of this system :

$$MA = \frac{ED}{LD} \quad \frac{12}{24} = \frac{1}{2} \text{ or } 0.5$$

Part II(b): Unbalanced Forces

Answers will vary. Possible answers:

1. 24 cm
2. 12 cm
3. Prediction.
4. About 2 pennies.
5. Mechanical advantage of this system :

$$MA = \frac{ED}{LD} \quad \frac{24}{12} = \frac{2}{1} \text{ or } 2$$

Conclusion

Sample responses: The benefit of a first class lever system is that it allows you to pick up bigger loads with less effort. You can do this by changing the distances between the effort and load forces and the fulcrum. A first class lever system that has the effort force at a greater distance from the fulcrum than the load force provides a greater mechanical advantage. The mechanical advantage of the system in **Part II(b)** was 2. With that system, I used two pennies (effort) to pick up four pennies (load). The mechanical advantage of the system in **Part II(a)** was 0.5. In this system, I needed eight pennies to pick up a load of four pennies.

Challenge

Answers will vary.

Tow Truck Worksheet

Observations

Weights

Load force: Answers will vary.

Winch

Effort radius (handle): Approx. 2.8 cm

Load radius (shaft): Approx. 0.25 cm

MA winch: Approx. 11.2

Think About

1. Answers will vary.
2. Possible answer: Increasing the length of the handle would increase the mechanical advantage of the winch. Increasing the length of the handle would reduce the amount of effort force needed to raise the weights.
3. Answers will vary. Possible answer: How large is the load? How much force can a person safely exert on the winch? What must be the mechanical advantage of the winch?

Challenge

Answers will vary. Student responses should center on a winch with a mechanical advantage equal to at least 10.

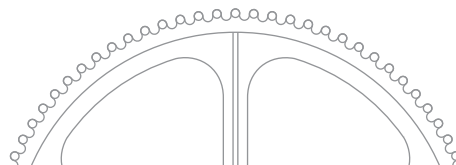

Teacher's Answer Sheet

Block and Tackle Worksheet

Observations

Tables 1 & 2: Answers will vary.

Think About

1. Possible answer: Effort force was the same as load force when lifted without movable pulleys. Effort force was less than load force each time movable pulleys were used.
2. Possible answer: Adding a second movable pulley reduced the amount of effort force needed to raise the tray.
3. Possible answer: Force was gained at the expense of distance. The rope had to be pulled ____ meters farther to move the load to the same 15 cm height.
4. Possible answer: Although less effort force went into moving the load using a single movable pulley, that effort force was applied over a longer distance. The increase in distance was shown by the fact that the pulley string had to be pulled for a longer distance.

Challenge

Answers will vary. In a machine, work input is always greater than work output because some energy is lost to friction caused by its moving parts.

Elevator Worksheet

Think About

1. Possible answer: Both numbers are approximately the same. Effort force was about the same as load force.
2. Possible answer: Both moved about the same distance.
3. Possible answer: Effort force was less than the weight of car B.
4. When a movable pulley system is used, effort force is decreased while the distance that the effort force must be applied increases.
5. Since the effort force was about the same as the load force, the MA for the single fixed pulley is about 1. Since approximately half as much effort force was used to move a car using a movable pulley system, the mechanical advantage of this system is about 2.

Challenge

Answers will vary. Accept all reasonable answers.

Possible answer: A pulley system that has both fixed and movable pulleys. The fixed pulleys allow the elevator to change direction. Movable pulleys reduce the amount of effort needed to raise an elevator full of people.

Screwdriver Worksheet

Observations

1. The weight attached to the handle.

Table 1: Answers will vary.

Think About

1. Answers will vary and are strongly dependent on the type of string used. If twine is used, then student averages may range between 9 to 10 cm for the wheel and 2 to 3 cm for the axle.
2. Answers will vary and are dependent upon the thickness and elasticity of the thread used.
Possible answer: Using twine, student answers will range between 3.4 and 3.8.
3. Answer should reflect the calculation from the previous question.
4. Distance is lost. Speed is lost.
5. Possible answer: If distance is lost, then force must be gained. The ratio of distances was greater than 1. A mechanical advantage greater than 1 means that force is multiplied.
6. $MA = 6$

Challenge

(a) In all likelihood, these calculations are not even close.

(b) Answers will vary. Possible answer: The calculations were not very close. Three things that could have affected the results: thickness of string, measurement mistakes, one string being more elastic than the other, etc.

Teacher's Answer Sheet

Paddlewheel Boat Worksheet

Observations

Table 1

Students should observe that with each turn of the rubber band the paddlewheels turn faster.

Table 2

Answers in Column 2 and 4 will vary.

Number of turns of rubber band	Spring Scale reading (N) (Convert grams if necessary) LOAD FORCE	Mechanical Advantage of the system	Calculated EFFORT FORCE to produce that Load Force
1		0.06	
2		0.06	
3		0.06	
4		0.06	

Think About

- Possible answer: The rubber band provided the effort force to turn the wheel and axle.
- Possible answer: The paddlewheels. The distance around the rim of the paddlewheel is greater than the distance around the axle, therefore the paddlewheels turned the greatest distance.
- Possible answer: Distance is gained. In Question 3, MA was less than 1. When MA is less than 1, then force is lost. If force is lost then distance is gained.
- Possible answer: Because the mechanical advantage of a wheel and axle system that applies force to the axle to drive the wheel is so small.
- Possible Answer: The line on my graph indicates how much the effort force increased with each turn of the rubber band. If the line is straight, students may suggest there is a direct relationship. If the line is curved, the results suggest that the different turns of the rubber band added differing amounts of energy to the system.

Challenge

- Accept all reasonable answers.
Possible answers: Use a shorter rubber band to increase the speed and distance. Make the paddlewheels smaller to increase the speed that it travels. Use a longer rubber band to increase the distance that it travels, etc.

Dump Truck Worksheet

Think About

- Answers will vary. Possible answer: Raising the box caused the paperclips to slide **over** the bottom of the box and out through the gate.
- Answers will vary. Possible answer: As the plow moves forward **through** the pile, the paperclips are pushed aside by the blade.
- Answers will vary. Possible answer: They are classified differently because they do different things. Objects move **over** ramps - items can be pushed up over ramps or they will slide down a ramp. Wedges move **through** objects and push them to one side or the other.
- Answers will vary. Possible answer: Two sloping surfaces will push substances such as soil apart, breaking up the ground.
- Answers will vary. Possible answer: Front teeth are more like wedges because they move through food and push it apart.

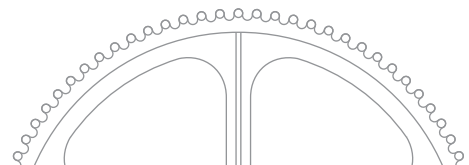

Teacher's Answer Sheet

Inclined Plane Worksheet

Observations

Length of ramp: 33 cm

Height of ramp: 7.5 cm

Ideal MA = 4.4

Load Force: Answers will vary.

Prediction: Answers will vary.

Effort force used to pull the weight to the top of ramp: Answers will vary.

Actual MA = Answers will vary.

Think About

1. Friction and/or experimental or equipment error.
2. Answers will vary. Possible answer: Inclined planes make work easier by reducing the amount of force needed to raise an object.
3. Answers will vary. Possible answer: The trade-off for using less force is exerting the smaller force over a greater distance.

Challenge

1. Answers will vary. Possible answer: Increasing the length of the ramp while keeping its height the same.
2. Answers will vary.

Archimedes' Screw Worksheet

Observations

Length of inclined plane: Approx. 45 cm

Length of cylinder: Approx. 32 cm

Turning the handle: Answers will vary. Possible answer: Turning the handle of the screw pushes the ball up the ramp.

Think About

1. Answers will vary. Possible answer: Force applied to the crank turns the screw. As the screw turns, the inclined plane of the screw exerts force on the ball and pushes it up the ramp.
2. Answers will vary. Possible answer: Since the length of the inclined plane wrapped around the cylinder is longer than the length of the cylinder, then force is gained at the expense of distance.
3. Possible answer: Increase the number of threads or turns on a screw.
4. Answers will vary. Possible answers: Farmers put the end of the Archimedes' Screw in a river or canal. When they turned the crank, water was pushed up the screw from the river to higher ground where their fields were located.
5. Possible answers: Grain elevator; pet food feed; pelletized fuel feed; pill conveyor; 'worm' drives; drills.
6. Answers will vary. Possible answer: An Archimedes' Screw is used to move loose material. A screw used as a fastener holds solid surfaces together.

Challenge

Answers will vary.

Possible answer: Student responses should include modifications that enclose the screw and alter the inclined plane to make it solid.

Conveyor Belt Worksheet

Observations

Table 1

	Number of Complete Rotations	Time (seconds)
Belt gear	20	Answers will vary
Shaft	20	Answers will vary
Crank	20	Answers will vary

Think About

1. Possible answer: Force applied to the handle is transferred through the axle to the belt gear which transfers force to the conveyor belt. The force is carried by the conveyor belt to the second gear. This causes the second gear to turn in the same direction.
2. Possible answer: Turning the wheel using the shaft required the most force because it was the hardest to turn.
3. The heavier the belt, the more force required to turn the crank.
4. Answers will vary. Answers should include: the handle, both gears and the belt all turn in the same direction. All the components turn in a rotational manner, but for a large distance the belt moves in a straight line as it moves from one gear to the other.
5. Answers will vary. Answers should include: As the belt moves from one gear to another, it travels in a straight line for a large distance. Items placed on the belt will move in a straight line until the belt reaches the second gear.
6. Answers will vary. Answers may include: The MA must be 1 (one) because both of the gears are the same size and they have the same number of teeth.
7. Answers will vary. Answers may include: They allow us to pedal a bicycle forward to go forward. If there were spur gears on a bike, you would have to pedal backwards to go forwards. They allow us to move items over great distances without the need for long gear trains.
8. Answers will vary. Possible answer: Designing conveyor walkways that go around corners would be too costly.

Challenge

1. Possible answer: If larger belt wheels were used, then the conveyor would move faster than the handle. If smaller belt wheels were used, then the conveyor would move at a slower speed than the handle.

Rack and Pinion Worksheet

Observations

Diameter of the pinion gear (d): 5.4 cm
 Circumference of the pinion gear: 16.96 cm
 Distance rack moved: Approximately 8.4 cm
 Distance the teeth of the pinion gear moved during one-half turn of the gear. Students should calculate using:
 $\text{Diameter of pinion gear}/2 = 16.96/2 = 8.48 \text{ cm}$

Think About

1. Answers will vary. Possible answer: They both moved approximately the same distance. This is because the distance between the gear teeth on the pinion is approximately the same as the distance between the teeth on the rack, if we measure from the middle of the teeth.
2. Answers will vary. Possible answers may include: The teeth on the pinion moved ____ cm and the rack moved ____ cm. I concluded that the formula for MA would be $MA = \text{Input distance}/\text{output distance}$ because when doing experiments with pulleys, that formula would have allowed me to find the MA.
3. Answers will vary. Possible answer: The rack moves in a linear or straight-line motion. The pinion moves in a rotational or circular motion.
4. Answers will vary. Possible answer: Force applied to the handle turns the pinion, which is on the same axle. As the pinion turns it transfers the force to the rack, causing the rack to move.
5. Answers will vary. Possible answer: It is useful because rotational motion can be changed into linear motion.

Challenge

Answers will vary.

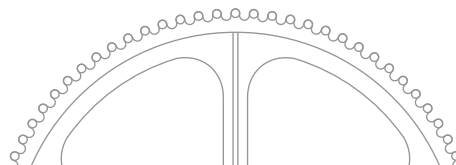

Teacher's Answer Sheet

Crank Fan Worksheet

Prediction

Answers will vary.

Observations

Number of revolutions completed by the driver gear: 1

Number of revolutions completed by the driven gear attached to the fan: 5.9

Gear ratio: 1: 5.9

Number of teeth on the driver gear: 82

Number of teeth on the driven gear: 14

Gear ratio: 1: 5.9

Think About

1. Possible answer: The two formulas produced similar results.
2. The fan turned much faster than the crank.
3. 1:1; the gears are the same size, therefore they must complete equal numbers of revolutions.
4. Answers will vary. Possible answer: The fan rotated in a direction that was opposite to the direction that the driver gear rotated. The driving gear changed the direction of input motion.

Challenge

1. Possible answer: When a smaller (driver) gear is used to turn a larger (driven) gear connected to the fan, the fan turns much more slowly.

Carousel Worksheet

Observations

Number of teeth on driver gear: 34

Number of teeth on the driven gear: 82

MA: 2.4

Think About

1. Answers will vary. Possible answer: The crown gear system made work easier by reducing the amount of effort force needed to turn the large gear. This system has a mechanical advantage of 2.4. A mechanical advantage greater than 1 means that force is gained.
2. Force is gained at the expense of speed and distance.
3. (i) Gears
(ii) Wheel and axle (the crank that you turn to operate the gears is a wheel and axle)
5. Answers will vary but expect students to mention that they change the direction of the effort force and they may multiply force.

Challenge

Answers will vary.

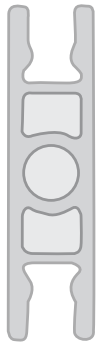

Teacher's Answer Sheet

Transmission Worksheet

Methods

1. Students responses should be either number of teeth on the two gears or number of revolutions of each gear.

Table 1

	Gear Ratio	Observations
First gear	Using the ratio of number of teeth: $34/14 = 2.4:1$	Answers will vary: Possible Answer: The small gear turns the large gear. The fan blades turn slowly.
Second gear	Using the ratio of number of teeth: $14/34 = 1:2.4$	Answers will vary: Possible Answer: The large gear turns the small gear. The fan blades turn fast. It is harder to turn the crank in second gear compared to first gear.

Think About

1. Answers will vary. Possible answer: The fan turns at different speeds because the sizes of the driver and driven gears are reversed when you shift gears. In first gear, a small gear is used to turn a large gear. In second gear, a large gear is used to turn a small gear.

2. Answers will vary. Possible answer: Turn the axle connected directly to the fan so the fan blades pass over one finger. The finger provides resistance to the motion of the fan. Shift the transmission into first gear. With finger in the same position as before, turn the fan in first gear and observe. Shift to second gear. Repeat as before and observe.

A second possible answer: Place the transmission model so that the fan blades and axle extend out over the edge of the desk. Use a small purple Connector to attach a 20 cm string to the axle of the fan. Tie a weight to the other end of the string. Engage first gear and turn the crank. Repeat using second gear. Compare the turning force required to lift the weight with the transmission in first gear, to the turning force required to lift the weight with the transmission in second gear.

3. First gear: the small driver gear turning the large driven gear slows the turning speed of the axle attached to the driven gear but increases the force (torque).

4. Answers will vary. Possible answer: The different ratios of gear teeth in a gear train produce different speeds and different amounts of torque. A gear ratio of 1:3 means that output speed is greater than input speed; this is what happens when I shift my bike into a high gear to go faster along a flat stretch of road. With a gear ratio of 3:1, however, speed is lost but force (torque) is multiplied, as happens when I ride my bike up a hill and shift into a low gear. I move forward slowly but more force is applied to the axle of the driven gear and the back wheel of the bike.

